



# MAINTENANCE Manual

*for* Laboratory Equipment

2nd Edition





# MAINTENANCE Manual

*for* Laboratory Equipment

2nd Edition



## WHO Library Cataloguing-in-Publication Data

Maintenance manual for laboratory equipment, 2<sup>nd</sup> ed.

1.Laboratory equipment. 2.Maintenance. 3.Manuals. I.World Health Organization. II.Pan American Health Organization.

ISBN 978 92 4 159635 0

(NLM classification: WX 147)

### © World Health Organization 2008

All rights reserved. Publications of the World Health Organization can be obtained from WHO Press, World Health Organization, 20 Avenue Appia, 1211 Geneva 27, Switzerland (tel.: +41 22 791 3264; fax: +41 22 791 4857; e-mail: [bookorders@who.int](mailto:bookorders@who.int)). Requests for permission to reproduce or translate WHO publications – whether for sale or for noncommercial distribution – should be addressed to WHO Press, at the above address (fax: +41 22 791 4806; e-mail: [permissions@who.int](mailto:permissions@who.int)).

The designations employed and the presentation of the material in this publication do not imply the expression of any opinion whatsoever on the part of the World Health Organization concerning the legal status of any country, territory, city or area or of its authorities, or concerning the delimitation of its frontiers or boundaries. Dotted lines on maps represent approximate border lines for which there may not yet be full agreement.

The mention of specific companies or of certain manufacturers' products does not imply that they are endorsed or recommended by the World Health Organization in preference to others of a similar nature that are not mentioned. Errors and omissions excepted, the names of proprietary products are distinguished by initial capital letters.

All reasonable precautions have been taken by the World Health Organization to verify the information contained in this publication. However, the published material is being distributed without warranty of any kind, either expressed or implied. The responsibility for the interpretation and use of the material lies with the reader. In no event shall the World Health Organization be liable for damages arising from its use.

Design and Layout: L'IV Com Sàrl, Morges Switzerland

Printed in Spain

#### Contact:

Dr G. Vercauteren, Coordinator, Diagnostics and Laboratory Technology, Department of Essential Health Technologies, World Health Organization, 20 Avenue Appia, 1211 Geneva 2, Switzerland

This document is available at [www.who.int/diagnostics\\_laboratory](http://www.who.int/diagnostics_laboratory)



# Table of Contents

<b>TABLE OF FIGURES</b>	viii
<b>ACKNOWLEDGEMENTS</b>	x
<b>INTRODUCTION</b>	xi
<b>CHAPTER 1 • MICROPLATE READER</b>	1
Photograph of microplate reader	1
Purpose of the microplate reader	1
Operation principles	1
Installation requirements	3
Routine maintenance	3
Troubleshooting table	4
Basic definitions	5
<b>CHAPTER 2 • MICROPLATE WASHER</b>	7
Photograph of microplate washer	7
Purpose of the microplate washer	7
Operation principles	7
Installation requirements	9
Routine maintenance	9
Troubleshooting table	11
Basic definitions	12
<b>CHAPTER 3 • pH METER</b>	13
Purpose of the equipment	13
Photograph and components of the pH meter	13
Operation principles	13
pH meter components	14
Typical circuit	15
Installation requirements	16
General calibration procedure	16
General maintenance of the pH meter	17
Basic maintenance of the electrode	18
Troubleshooting table	18
Basic definitions	19
Annex: The pH theory	20

<b>CHAPTER 4 • BALANCES</b>	21
Photographs of balances	21
Purpose of the balance	22
Operation principles	22
Installation requirements	26
Routine maintenance	27
Troubleshooting table	28
Basic definitions	29
<b>CHAPTER 5 • WATER BATH</b>	31
Diagram of a water bath	31
Operation principles	31
Water bath controls	32
Water bath operation	32
Troubleshooting table	34
Basic definitions	34
<b>CHAPTER 6 • BIOLOGICAL SAFETY CABINET</b>	35
Illustration of a biological safety cabinet	35
Purposes of the equipment	35
Operation principles	35
Biological safety	39
Installation requirements	39
Using the safety cabinet	39
Routine maintenance	40
Functional evaluation (alternative)	41
Table of functional evaluation of biological safety cabinets	42
Troubleshooting table	43
Basic definitions	44
<b>CHAPTER 7 • CENTRIFUGE</b>	45
Photograph of centrifuge	45
Purpose of the centrifuge	45
Operation principles	45
Components of the centrifuge	46
Installation requirements	48
Routine maintenance	48
Appropriate management and storage recommendations	48
Troubleshooting table	50
Basic definitions	52
<b>CHAPTER 8 • WATER DISTILLER</b>	53
Diagram of a water distiller	53
Purpose of the water distiller	53
Operation principles	54
Installation requirements	54
Routine maintenance	55
Troubleshooting table	56
Basic definitions	57

<b>CHAPTER 9 • DILUTOR</b>	59
Diagram of a dilutor	59
Purpose of the dilutor	59
Operation principles	60
Installation requirements	61
Routine maintenance	61
Troubleshooting table	63
Basic definitions	64
<b>CHAPTER 10 • DISPENSER</b>	65
Photograph and diagram of the dispenser	65
Purpose of the dispenser	65
Requirements for operation	67
Routine maintenance	67
Troubleshooting table	68
Basic definitions	68
<b>CHAPTER 11 • SPECTROPHOTOMETER</b>	69
Photograph of spectrophotometer	69
Purpose of the equipment	69
Operation principles	69
Spectrophotometer components	72
Installation requirements	73
Spectrophotometer maintenance	73
Good practices when using the spectrophotometer	75
Troubleshooting table	77
Basic definitions	79
<b>CHAPTER 12 • AUTOCLAVE</b>	81
Photograph of the autoclave	81
Purpose of the autoclave	81
Operation principles	82
Operation of the autoclave	84
Installation requirements	87
Routine maintenance	88
Maintenance of specialized components	90
Troubleshooting table	91
Basic definitions	92
<b>CHAPTER 13 • DRYING OVEN</b>	93
Photograph of drying oven	93
Purpose of the oven	93
Operating principles	93
Installation requirements	94
Oven operation	94
Oven controls	95
Quality control	96
Routine maintenance	96
Troubleshooting table	97
Basic definitions	98

<b>CHAPTER 14 • INCUBATOR</b>	99
Photograph of incubator	99
Operating principles	99
Incubator controls	101
Installation requirements	101
Routine maintenance and use of the incubator	101
Troubleshooting table	103
Basic definitions	104
<b>CHAPTER 15 • MICROSCOPE</b>	105
Photographs of microscopes	105
Purpose of the equipment	106
Operation principles	106
Installation requirements	108
Description of potential problems with microscopes	109
General maintenance of the microscope	111
Troubleshooting table	115
Basic definitions	116
<b>CHAPTER 16 • PIPETTES</b>	119
Photographs of pipettes	119
Purpose of the pipettes	120
Operation principles of the pipette	120
Requirements for use	120
Using the pipette	121
Routine maintenance	122
Troubleshooting table	125
Basic definitions	126
<b>CHAPTER 17 • STIRRING HEATING PLATE</b>	127
Photograph of the stirring heating plate	127
Operation principles	127
Controls of the stirring heating plate	127
Installation requirements	128
Operation of the stirring heating plate	128
Routine maintenance	128
Troubleshooting table	129
Basic definitions	129
<b>CHAPTER 18 • REFRIGERATORS AND FREEZERS</b>	131
Photograph of a refrigerated storage unit	131
Purpose of refrigerated storage units	132
Operation principles	132
Installation requirements	133
Refrigerator control circuit	134
Refrigerator operation	134
Refrigerator routine maintenance	135
Troubleshooting table	137

Operation of ultralow freezers	138
Turning the unit on	138
Routine maintenance	139
Troubleshooting table	140
Basic definitions	141

<b>CHAPTER 19 • CHEMISTRY ANALYSERS</b>	143
Photographs of chemistry analysers	143
Purpose of chemistry analysers	144
Operation principle	144
Components	144
Installation requirements	145
Operation of the dry chemistry analyser	145
Operation of the wet chemistry analyser	146
Routine maintenance of chemistry analysers	146
Non-routine maintenance and troubleshooting	147
Troubleshooting table	148
Basic definitions	148

<b>CHAPTER 20 • COLORIMETERS</b>	149
Photograph of colorimeter	149
Purpose of the colorimeter	149
Operating principle	149
Components	150
Installation requirements	150
Operation of the colorimeter	150
Operation of the haemoglobinometer	151
Routine maintenance	151
Troubleshooting table	154
Basic definitions	155

<b>BIBLIOGRAPHY</b>	157
---------------------	-----





# Table of Figures

Figure 1	Equipment used for ELISA tests	2
Figure 2	Microplate washer	8
Figure 3	Well profiles	8
Figure 4	Diagram of a pH meter	14
Figure 5	Types of electrodes	15
Figure 6	Example of a typical pH meter control circuit	15
Figure 7	Spring balance	22
Figure 8	Sliding weight scale	22
Figure 9	Analytical balance	22
Figure 10	Upper plate balance	23
Figure 11	Substitution balance	23
Figure 12	Components of the electronic balance	24
Figure 13	Compensation force principle	24
Figure 14	Classification of balances by exactitude	25
Figure 15	Analytical balance control panel	26
Figure 16	Water bath	31
Figure 17	Immersion and external resistors	31
Figure 18	Water bath controls	32
Figure 19	Biological safety cabinet	35
Figure 20	Centrifugal force concept	46
Figure 21	Water distiller	53
Figure 22	Dilutor diagram	59
Figure 23	Dilutor controls	60
Figure 24	Syringe and dispenser	61
Figure 25	Dispenser	65
Figure 26	Dispenser and accessories	66
Figure 27	Interaction of light with matter	70
Figure 28	Absorbance phenomenon	71
Figure 29	Spectrophotometer components	72
Figure 30	Refraction of light	79
Figure 31	Diffraction grid	80
Figure 32	Vapour circuit of an autoclave	83
Figure 33	Space required for autoclave	87
Figure 34	Compressed air connection	87
Figure 35	Vapour connection	88
Figure 36	Vapour generator	89
Figure 37	Electronic control of the oven	95
Figure 38	Electrical circuit of the oven	95
Figure 39	Heat transfer systems used in incubators	100

Figure 40	Incubator controls	101
Figure 41	Positive (convergent) lens	106
Figure 42	Optics of the convergent lens	106
Figure 43	Diagram of a microscope	107
Figure 44	Cross-section of a microscope	108
Figure 45	Binocular head	109
Figure 46	Lighting system	109
Figure 47	Platform, plate or mechanical stage	110
Figure 48	Revolving, objective holder	110
Figure 49	Body of the microscope	111
Figure 50	Diagram of a pipette	119
Figure 51	Types of pipettes	120
Figure 52	Phases of pipette use	121
Figure 53	Disassembly of a pipette	123
Figure 54	Stirring heating plate controls	127
Figure 55	Induction motor	129
Figure 56	Refrigeration circuit	132
Figure 57	Control circuit of the refrigerator	134
Figure 58	Blood bank refrigerator controls	135
Figure 59	Ultralow temperature freezer control	138
Figure 60	Basic diagram of reflectance photometry on a test strip	144
Figure 61	Ulbricht's sphere	145
Figure 62	Basic components of a photometer	145
Figure 63	Controls of a portable colorimeter	150



# Acknowledgements

This manual is a revised edition of “Manual de mantenimiento para equipo de laboratorio” (PAHO, 2005) translated from Spanish into English. Revisions include additional chapters on laboratory equipment commonly used in some laboratories and updates allowing global use of the manual.

The revised version has been prepared under the direction of Dr Gaby Vercauteren, World Health Organization, Geneva, Switzerland and in coordination with Dr Jean-Marc Gabastou, Pan-American Health Organization/World Health Organization, Washington, DC, USA; translated by Ms Christine Philips; reviewed by Ms Mercedes Pérez González and adapted, revised and edited by Mrs Isabelle Prud’homme.

WHO kindly expresses thanks to those who have participated at all levels in the elaboration of this manual. WHO wishes to acknowledge the original contribution of Dr Jorge Enrique Villamil who wrote the first edition of this manual in 2005 (Manual para mantenimiento de equipo de laboratorio, ISBN 92 75 32590 1) and Dr Jean-Marc Gabastou and Mr Antonio Hernández, Reviewers at Essential Medicines Vaccines and Health Technologies at PAHO.

WHO also thanks manufacturers who have granted permission to use their images in this publication.





# Introduction

This manual has been developed to support personnel employed in health laboratories. Its purpose is to give a better understanding of the technical requirements regarding installation, use and maintenance of various types of equipment which play an important role in performing diagnostic testing. The manual also aims to provide support to personnel responsible for technical management, implementation of quality management and maintenance.

Due to the diversity of origins, brands and models, this manual offers general recommendations. Equipment-specific details are explained in depth in the maintenance and installation user manuals from manufacturers. These should be requested and ordered through the procurement processes of the individual agencies and professionals responsible for the acquisition of technology, or directly from the manufacturer.

This manual was originally developed by the Pan-American Health Organization (PAHO) to support improved quality programmes which PAHO promotes in regional laboratories. The English version was produced by WHO to further expand support for quality programmes in other regions. The revised edition now includes 20 equipment groups selected to cover those most commonly used in low to medium technical complexity laboratories across the world. Given the differences in technical complexity, brands and existing models, each chapter has been developed with basic equipment in mind, including new technology where relevant. The following information is included in each chapter:

- Groups of equipment, organized by their generic names. Alternative names have also been included.
- Photographs or diagrams, or a combination of both to identify the type of equipment under consideration.
- A brief explanation on the main uses or applications of the equipment in the laboratory.
- A basic description of the principles by which the equipment operates with explanations of principles or physical and/or chemical laws which the interested reader can – or should study in depth.
- Installation requirements with emphasis on the electrical aspects and the requirements for safe installation and operation, including worldwide electrical standards.
- Basic routine maintenance, classified according to the required frequency (daily, weekly, monthly, quarterly, annually or sporadically). The procedures are numbered and presented in the actual sequence in which these should take place (model-specific procedures can be found in the manuals published by the manufacturers).
- Troubleshooting tables with the most frequent problems affecting the equipment with possible causes and actions that may resolve these problems.
- A list of basic definitions of some of the specialized terms used.
- For some equipment, additional themes related to calibration, quality control and design (with operational controls).

This information, along with good use and care, helps to maintain laboratory equipment in optimal condition.



# Chapter 1



## Microplate Reader

<b>GMDN Code</b>	<b>37036</b>
<b>ECRI Code</b>	<b>16-979</b>
<b>Denomination</b>	<b>Photometric micro-plate reader</b>

The microplate reader also known as “Photometric micro-plate reader or ELISA reader” is a specialized spectrophotometer designed to read results of the ELISA test, a technique used to determine the presence of antibodies or specific antigens in samples. The technique is based on the detection of an antigen or antibodies captured on a solid surface using direct or secondary, labelled antibodies, producing a reaction whose product can be read by the spectrophotometer. The word ELISA is the acronym for “Enzyme-Linked Immunosorbent Assay”. This chapter covers the use of microplate readers for ELISA testing. For additional information on the instrument principles of operation and maintenance, consult Chapter 11 discussing the spectrophotometer.

### PHOTOGRAPH OF MICROPLATE READER



Photo courtesy of BioRad Laboratories

### PURPOSE OF THE MICROPLATE READER

The microplate reader is used for reading the results of ELISA tests. This technique has a direct application in immunology and serology. Among other applications it confirms the presence of antibodies or antigens of an infectious agent in an organism, antibodies from a vaccine or auto-antibodies, for example in rheumatoid arthritis.

### OPERATION PRINCIPLES

The microplate reader is a specialized spectrophotometer. Unlike the conventional spectrophotometer which facilitates readings on a wide range of wavelengths, the microplate reader has filters or diffraction gratings that limit the wavelength range to that used in ELISA, generally between 400 to 750 nm (nanometres). Some readers operate in the ultraviolet range and carry out analyses between 340 to 700 nm. The optical system exploited by many manufacturers uses optic fibres to supply light to the microplate wells containing the samples. The light beam, passing through the sample has a diameter ranging between 1 to 3 mm. A detection system detects the light coming from the sample, amplifies the signal and determines the sample’s absorbance. A reading system converts it into data allowing the test result interpretation. Some microplate readers use double beam light systems.

Test samples are located in specially designed plates with a specific number of wells where the procedure or test is carried out. Plates of 8 columns by 12 rows with a total of 96 wells are common. There are also plates with a greater number of wells. For specialized applications, the current trend is to increase the number of wells (384-well plates) to reduce the amount of reagents and samples used and a greater throughput. The location of the optical sensors of the microplate reader varies depending on the manufacturers: these can be located above the sample plate, or directly underneath the plate’s wells.

Nowadays microplate readers have controls regulated by microprocessors; connection interfaces to information systems; quality and process control programs, which by means of a computer, allow complete test automation.



### Equipment required for ELISA testing

In order to perform the ELISA technique, the following equipment is required:

1. Microplate reader.
2. Microplate washer (Chapter 2).
3. Liquid dispensing system (multi-channel pipettes may be used).
4. Incubator to incubate the plates.

Figure 1 illustrates how this equipment is interrelated.

### Mechanical phases of the ELISA technique

#### Using the equipment

When an ELISA test is conducted, it typically follows these steps:

1. A first washing of the plate may be done using the microplate washer.
2. Using a liquid dispenser or the multi-channel pipettes, wells are filled with the solution prepared to be used in the test.
3. The plate is placed in the incubator where at a controlled temperature, a series of reactions take place.

Stages 1, 2 and 3 can be repeated several times depending on the test, until the reagents added have completed their reactions.

Finally, when all the incubation steps have been completed, the plate is transferred to the microplate reader. The reading of the plate is done and a diagnosis can be deduced.

### Biochemical phases of the ELISA technique<sup>1</sup>

The ELISA technique from a biochemical point of view:

1. The plate wells are coated with antibodies or antigens.
2. Samples, controls and standards are added to the wells and incubated at temperatures ranging between room temperature and 37 °C for a determined period of time, according to the test's characteristics. During the incubation, the sample's antigen binds to the antibody coated to the plate; or the antibody in the sample binds to the antigen coated on the plate, according to their presence and quantity in the sample analyzed.
3. After incubation, the unbound antigen or antibodies are washed and removed from the plate by the microplate washer using an appropriate washing buffer.
4. Next, a secondary antibody, called the conjugate, is added. This harbours an enzyme which will react with a substrate to produce a change of colour at a later step.
5. Then begins a second period of incubation during which this conjugate will bind to the antigen-antibody complex in the wells.
6. After the incubation, a new washing cycle is done to remove unbound conjugate from the wells.
7. A substrate is added. The enzyme reacts with the substrate and causes the solution to change in colour. This will indicate how much antigen-antibody complex is present at the end of the test.
8. Once the incubation time is completed, a reagent is added to stop the enzyme-substrate reaction and to prevent further changes in colour. This reagent is generally a diluted acid.
9. Finally, the plate is read by the microplate. The resulting values are used to determine the specific amounts or the presence of antigens or antibodies in the sample.

Figure 1. Equipment used in ELISA tests

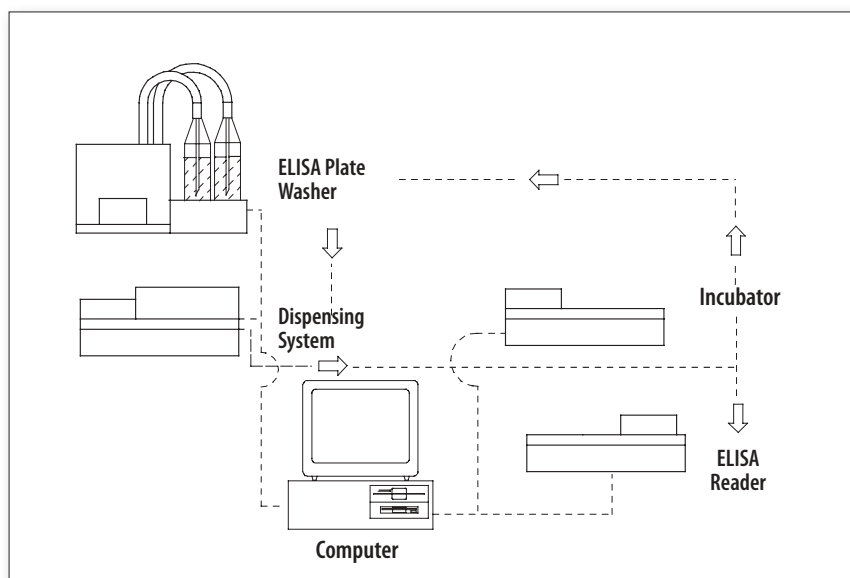

**Note:** Some of the wells are used for standards and controls. Standards allow the cut-off points to be defined. The standards and controls are of known quantities and are used for measuring the success of the test, evaluating data against known concentrations for each control. The process described above is common, although there are many ELISA tests with test-specific variants.

<sup>1</sup> More detailed explanations must be consulted in specialized literature.

## INSTALLATION REQUIREMENTS

In order for the microplate reader to operate correctly, the following points need to be respected:

1. A clean, dust free environment.
2. A stable work table away from equipment that vibrates (centrifuges, agitators). It should be of a suitable size so that there is working space at the side of the microplate reader. The required complementary equipment for conducting the technique described above is: washer, incubator, dispenser and computer with its peripheral attachments.
3. An electrical supply source, which complies with the country's norms and standards. In the countries of the Americas for example, 110 V and 60 Hertz frequencies are generally used, whereas other regions of the World use 220-240V, 50/60HZ.

### Calibration of the microplate reader

The calibration of a microplate reader is a specialized process which must be executed by a technician or trained engineer following the instructions provided by each manufacturer. In order to do the calibration, it is necessary to have a set of grey filters mounted on a plate of equal geometric size to those used in the analyses. Manufacturers provide these calibration plates for any wavelength the equipment uses.

Calibration plates are equipped with at least three pre-established optic density values within the measurement ranges; low, medium, and high value. In order to perform the calibration, follow this process:

1. Place the calibration plate on the equipment.
2. Carry out a complete reading with the calibration plate. Verify if there are differences in the readings obtained from well to well. If this is the case, invert the plate (180°) and repeat the reading to rule out that differences are attributed to the plate itself. In general, it is accepted that the instrument does not need further calibration if the plate results are as expected at two wavelengths.
3. Verify if the reader requires calibration. If so, proceed with the calibration following the routine outlined by the manufacturer, verifying that the reading's linearity is maintained as rigorously as possible.
4. If the instrument does not have a calibration plate, verify it by placing a coloured solution in the wells of a plate and immediately carry out a complete reading. Then invert the plate 180° and read the plate again. If both readings display identical, average values in each row, the reader is calibrated.

5. Verify that the reader is calibrated, column by column. Place a clean, empty plate and carry out a reading. If there is no difference between each of the average reading of the first to the last column, it can be assumed that the reader is calibrated.

## ROUTINE MAINTENANCE

Maintenance described next focuses exclusively on the microplate reader. The maintenance of the microplate washer is described in Chapter 2.

### Basic maintenance

#### Frequency: Daily

1. Review that optical sensors of each channel are clean. If dirt is detected, clean the surface of the windows of the light emitters and the sensors with a small brush.
2. Confirm that the lighting system is clean.
3. Verify that the reader's calibration is adequate. When the daily operations begin, let the reader warm up for 30 minutes. Next, do a blank reading and then read a full plate of substrate. The readings must be identical. If not, invert the plate and repeat the reading in order to determine if the deviation originated in the plate or the reader.
4. Examine the automatic drawer sliding system. It must be smooth and constant.

### Preventive maintenance

#### Frequency: Quarterly

1. Verify the stability of the lamp. Use the calibration plate, conducting readings with intervals of 30 minutes with the same plate. Compare readings. There must be no differences.
2. Clean the detectors' optical systems and the lighting systems.
3. Clean the plate drawer.
4. Verify the alignment of each well with the light emission and detection systems.



TROUBLESHOOTING TABLE		
PROBLEM	PROBABLE CAUSE	SOLUTION
The reader gives a reading that does not make sense.	The illumination lamp is out of service.	Replace the lamp with one with the same characteristics as the original.
The reader's readings vary from row to row.	Dirty optical sensors.	Clean the sensors.
	The illumination system's lenses or parts are dirty.	Clean the lighting system's lenses.
	Lack of calibration in one or more channels.	Verify the calibration of each one of the channels.
The reader displays high absorbance values.	Reagents expired and/or incorrectly prepared.	Check to see if the TMB is colourless and the preparation adequate.
	Contamination with other samples.	Repeat the test verifying the labelling, the washer and how the pipette was used.
	Incorrect wavelength filter.	Verify the recommended wavelength for the test. Adjust if it is incorrect.
	Insufficient or inefficient washing.	Verify the washing method used. Use an appropriate quality control test.
	Very long incubation time or very high temperature.	Check incubation times and temperatures.
	Incorrect sample dilution.	Check process for sample dilution.
	Some reagent was omitted.	Verify that the test has been carried out according to the established procedure.
The reader displays low absorbance values.	Very short incubation time and very low temperature.	Check temperatures and incubation times.
	The reagents were not at room temperature.	Check that the reagents are stable at room temperature.
	Excessive washing of the plate.	Adjust the washing process to what the test manufacturers indicate.
	Incorrect wavelength filter.	Verify the wavelength selected. Use wavelength recommended for the test.
	Expired or incorrectly prepared reagents.	Check the used reagents. Test the dilutions.
	A reagent was omitted.	Verify that the test was done according to the established procedure.
	The plate displays scratches at the bottom of the wells.	Prepare a new plate and repeat the test.
	Incorrectly selected or dirty plate.	Verify the type of plate used. Prepare a new plate and repeat the test.
	The plate wells have dried up.	Change the manner in which the plate is washed.
	The plate is incorrectly placed or is seated unevenly in the reader.	Check the placement of the plate. Repeat the reading.
	Humidity or fingerprints on the outer part of the bottom of the plate.	Verify that the plate under the bottom of the wells is clean.
	Residual quantities of washing buffer in the wells before adding the substrate.	Confirm that the washing buffer is completely removed.
	The substrate tablets do not dissolve completely.	Verify that the tablets dissolve correctly.
	The substrate tablet has been contaminated by humidity or metal clips or is not complete.	Test the integrity and handling of substrate tablets.
The position of the blank well could have been changed and an incorrect quantity has been subtracted at each reading.	Verify that the plate set-up is correct.	
The reader displays unexpected variation in the optical density readings.	The reader's lamp is unstable.	Replace the lamp with one that has similar characteristics as the original.
The reader displays a gradual increase or decrease from column to column.	Inappropriate calibration of the plate's advance motor.	Calibrate the advance so that at each step the wells remain exactly aligned with the lighting system.
The optical density readings are very low compared to the operator's optical evaluation criteria.	The reading is being carried out with a different wavelength than required for the test.	Verify the wavelength used when conducting the reading. If this is the problem, adjust the wavelength and repeat the reading. Verify that the recommended wavelength filter has been selected.

Low reproducibility.	Sample homogeneity.	Mix the reagents before use. Allow these to equilibrate to room temperature.
	Incorrect pipetting procedure.	Ensure pipette's tips are changed between samples and that excessive liquid inside is removed.
	Reader not calibrated.	Check the calibration. Use an appropriate quality control set.
	Reading without sufficient warming time of the instrument.	Wait until the reader has warmed up to its operating temperature.
	Expired reagents.	Verify the expiry dates of the reagents.
	Insufficient or inefficient washing.	Remove the buffer from the washer. Check that the wells are filled and aspirated in a uniform manner when washed.
The blank sample shows high absorbance.	Contaminated substrate.	Check that TMB is colourless and its preparation.
The data are not transferred from the reader to the microprocessor.	The reader and the microprocessor have differently defined codes.	Verify selected codes.
	Different (Baud) information transfer rates.	Confirm transfer rates selected.
	Incorrect configuration selected for the reception/transmission plugs.	Review the configuration of the plugs. The configuration must follow parameters defined by the manufacturer.
Misaligned light beam.	The reader was transferred or moved without using the necessary precautions.	Call the specialized service technician.
	The light source – lamp – has been changed and the replacement has not been installed or aligned correctly.	Verify its assembly and alignment.
Incorrect identification of the sample.	The plate was incorrectly loaded.	Check the samples' identification process. Repeat the reading carrying out the adjustments.
	Incorrect identification of the sample registered in the reader.	Check the samples' identification process. Repeat the reading carrying out the adjustments.
Computer fails to indicate the error codes.	The programme which controls the activation of alarms and warning messages is defective or is not validated by the manufacturer.	Call the specialized service technician.
The reader demonstrates failure in detecting errors.	Various components of the system display failure, such as the liquid level detection system.	Call the specialized service technician.

## BASIC DEFINITIONS

**Chemiluminescence.** Emission of light or luminescence resulting directly from a chemical reaction at environmental temperatures.

**ELISA** (Enzyme-Linked Immunosorbent Assay). Biochemical technique used mainly in Immunology to detect the presence of an antibody or an antigen in a sample.

**ELISA plate.** Consumable standardized to carry out the ELISA technique. Generally, plates have 96 wells in a typical configuration of 8 rows by 12 columns. There are also ELISA plates with 384 wells or up to 1536 wells for specialized high throughput testing in centres with high demand.

**Microplate washer.** Equipment used for washing plates during specific stages of an ELISA test with the aim of removing unbound components during reactions. Microplate washers use special buffers in the washing process.

**Enzyme.** Protein that accelerates (catalyses) chemical reactions.

**Fluorophore.** Molecules absorbing light at a determined wavelength and emitting it at a higher wavelength.

**Microplate reader.** The name given to spectrophotometers with the capacity to read microplates.

**TMB.** Tetramethylbenzidine, a substrate for the horseradish peroxidase (HRP) enzyme.



# Chapter 2

## Microplate Washer

<b>GMDN Code</b>	17489
<b>ECRI Code</b>	17-489
<b>Denomination</b>	Micro-plate washer

The microplate washer or “plate or ELISA washer” is designed to perform washing operations required in the ELISA technique. The microplate washer performs the washing of the ELISA plate’s wells during the different stages of the technique.

### PHOTOGRAPH OF MICROPLATE WASHER



Photo courtesy of BioRad Laboratories

### PURPOSE OF THE MICROPLATE WASHER

The microplate washer has been designed to supply cleaning buffers required for the ELISA technique in a controlled manner. In the same fashion, the equipment removes from each well, substances in excess from the reaction. Depending on the test performed, the washer can intervene from one to four times, supplying the washing buffer, agitating and removing the unbound reagents<sup>1</sup> until the programmed times and cycles are completed. The washer has of two reservoirs; one for the washing buffer, the other for the waste generated during the washing process.

### OPERATION PRINCIPLES

The microplate washer has been designed to perform washing operations in the ELISA technique. The equipment possesses at least, the following subsystems which vary depending on the manufacturer’s design.

- Control subsystem.** Generally, the washer is controlled by microprocessors allowing programming and controlling steps to be performed by the washer such as: number of washing cycles<sup>2</sup> (1–5); expected times; supplying and extracting pressures; plate format (96–384 wells); suction function adjustment according to the type of well<sup>3</sup> (flat bottom, V bottom or rounded bottom or strips used); volumes distributed or aspirated; the soaking and agitation cycles, etc.
- Supply subsystem.** In general, this comprises a reservoir for the washing solution; one or several pumps; usually a positive displacement type syringe and a dispenser head that supplies the washing solution to the different wells by means of needles. The head usually comes with eight pairs of needles for washing and aspirating simultaneously the wells of the same row (the supply and extraction sub-systems converge on the head). There are models with twelve pairs of needles and others that conduct the washing process simultaneously in all the wells. Some washers offer the possibility of working with different types of washing solutions, performing the solution changes according to the program entered by the operator.

<sup>1</sup> See a brief explication of the ELISA technique in Chapter 1, *Microplate Reader*.

<sup>2</sup> The exact number of washing operations required depends on the assay used. This is explained in each manufacturer’s test instruction manual.

<sup>3</sup> If the bottom is flat, the suction needle is located very close to one of well’s faces; if it is rounded or V-shaped, the suction needle is centered.

- **Extraction or suction system.** This requires a vacuum mechanism and a storage system for gathering the fluids and waste removed from the wells. The vacuum may be supplied by external and internal pumps. Extraction is done by a set of needles mounted on the washer/dryer's head. The number of needles varies from one to three, according to the washer model used.

If it uses only one needle, the washing and extraction operation is done with this single needle. If it uses two needles, one is used for supplying the washing solution and the other for extraction. If it uses three needles, the first is used for supplying the washing solution, the second for extraction and the third for controlling (extracting) any excess volume in the well. Generally, the extraction needle is longer than the supply needle, which enables it to advance (vertically) up to a height ranging between 0.3 and 0.5 mm from the bottom of the well.

- **Advance sub-system.** This is composed of a mechanism which moves the supply and extraction head horizontally to reach each well in the ELISA plate. When the horizontal movement to the following row occurs, there is a vertical movement towards the well to dispense or extract the washing solution. There are washers which carry out these operations in a simultaneous manner.

The sub-systems previously described are shown in Figure 2. Figure 3 shows the different types of wells most commonly found in microplates. Each kind of well is suitable for a particular type of test.

### Washing process

The washing of the microplate is one of the stages of the ELISA technique. Special solutions are used in the washing steps. Among those most commonly used is phosphate buffer solution or PBS. The phosphate buffer solution has a stability of 2 months if kept at 4 °C. It is estimated that 1 to 3 litres of solution is required for washing one microplate and that 300  $\mu\text{l}$  is used in each well per cycle. Washing can be done manually, but it is preferable to use an automated microplate washer for a better throughput and to minimize handling of potentially contaminated substances.

Among the washing processes used by microplate washers are featured:

- **Aspiration from top to bottom.** When the aspiration phase is initiated, the needles move vertically and the aspiration is initiated immediately as these enter into the liquid. The process continues until the needles reach their lowest position very close to the bottom of the wells. At this point they are stopped in order to avoid suctioning the air that should flow against the interior lateral walls of the wells. This type of aspiration prevents air currents from drying the bound protein on the surface of the wells.

Figure 2. Microplate washer

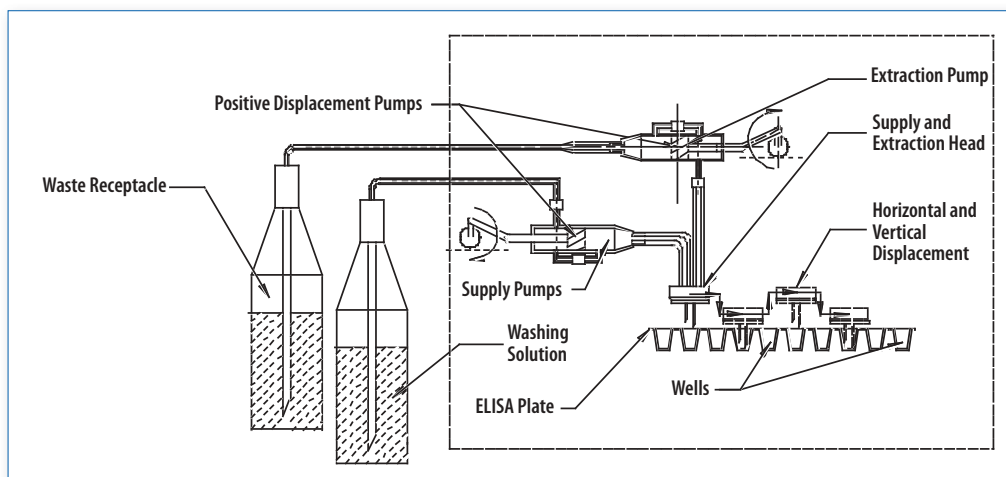
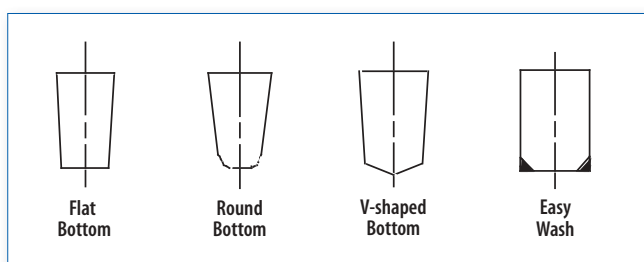

Figure 3. Well profiles



- **Simultaneous distribution and aspiration.** In certain types of washer, the washing and aspiration systems operate simultaneously, generating a controlled turbulence inside the well which removes the unbound substances during the incubations.
- **Aspiration from the base of the wells.** In this system, the aspiration of the fluid contained in the wells is performed initially with the aspiration needles in a position very close to the bottom, immediately beginning a suctioning cycle, usually time-controlled. This system may aspirate air if there are differences in the levels of the tanks.

### Washer calibration

The microplate washer is critical for guaranteeing that the ELISA technique performs as expected. The alignment to be taken into account for the effective functioning of the equipment is presented next:

- **Position of the needles (supply and aspiration head).** The horizontal and vertical position adjustment with respect to the wells must be verified carefully. If the plate has flat bottom wells, the supply needle must be checked to see that it is situated very close to the well's wall. If the bottom is round or V-shaped, the suction needle should be located in the centre of the well: upon the vertical movement, a needle-base distance is maintained in the well, usually between 0.3 to 0.5 mm. The needles must never be allowed to touch the bottom of the wells to avoid mechanical interferences between the needle point and the well's base during the aspiration function.
- **Aspiration time.** Appropriately adjust the aspiration time so that a solution film adhered to the well's wall can flow towards the bottom. Avoid very long time lapses to prevent the coating on the wells from drying up. Check that the suction system's needles are clean (free of obstructions).
- **Distributed Volume.** Check that the volume distributed is as close as possible to the maximum capacity of the well; confirm that all the wells are filled uniformly (at the same level). Verify that the distributing needles are clean (free of obstructions).
- **Vacuum.** The suctioning system must be calibrated efficiently. If the vacuum is too strong, the test can be altered. In fact, it could dry out the wells and considerably weaken the enzyme activity in the wells and completely alter the test result. The majority of washers function with a vacuum ranging between 60 and 70% of atmospheric pressure. In some washers, the vacuum is made in an external pump which operates as an accessory of the washer. Its operation is controlled by the washer, which means that the vacuum pump operates only when required.

### Washing process verification

To verify that the washing process is done according to the specifications of ELISA techniques, manufacturers of ELISA tests have developed procedures to be carried out regularly. One of the controls<sup>1</sup> is based on using the peroxidase reagent, which is dispensed using a pipette in the plate wells to be read at 405, 450 and 492 nm. At once the wells are washed and a colourless substrate is added (TMB/H<sub>2</sub>O<sub>2</sub>–Tetramethylbenzidine/Hydrogen Peroxide). Whatever conjugate remains will hydrolyze the enzyme and the chromogen will change to blue. After stopping the reaction with acid, the TMB will turn yellow again. The resulting colour intensity is directly related to the washing process efficiency.

### INSTALLATION REQUIREMENTS

For the microplate washer to operate correctly, the following is necessary:

1. A clean, dust-free environment.
2. A stable work table located away from equipment that generates vibrations, (centrifuges, and agitators). It must be of a suitable size to locate the necessary complementary equipment: reader, incubator, distributor and computer with its peripheral attachments at the side of the microplate washer.
3. An electric outlet in good condition with a ground pole and, an electrical connection which complies with the country's or the laboratory's norms and standards. In the countries of the Americas, the 110V and 60 Hz frequency is generally used. In other parts of the World, the 220-240 V and 50/60 Hz frequency is generally used.

### ROUTINE MAINTENANCE

The routine maintenance described next focuses exclusively on the microplate washer. Maintenance of the microplate reader is dealt with in the Chapter 1.

#### Basic maintenance

##### Frequency: Daily

1. Verify the volume distributed.
2. Test the filling uniformity.
3. Verify the aspiration sub-system's efficiency.
4. Confirm the cleaning of the supply and extraction needles.
5. Clean the washer with distilled water after use, to remove every vestige of salt in the supply and extraction sub-systems' channels. The needles may be kept submerged in distilled water.
6. Verify that the body of the washer has been cleaned. If necessary, clean the exterior surfaces with a piece of cloth, moistened with a mild detergent.

<sup>1</sup> Procedure developed by PANBIO, *ELISA Check Plus*, Cat. Nº E-ECP01T.

### Preventive maintenance

#### Frequency: Quarterly

1. Disassemble and clean the channels and connectors. Verify their integrity. If leaks or any vestiges of corrosion are detected, adjust and/or replace.
2. Verify the integrity of the mechanical components. Lubricate according to the manufacturer's instructions.
3. Test the adjustment of each one of the sub-systems. Calibrate according to the manufacturer's recommendations.
4. Confirm the integrity of the electrical connector and the inter-connection cable.
5. Clean the washer with distilled water after using it in order to remove every vestige of salt in the supply and extraction subsystems' channels.
6. Verify the integrity of the fuse, and that its contact points are clean.

**Note:** Trained technical personnel must carry out maintenance of the control system. If necessary, call the manufacturer or representative.

TROUBLESHOOTING TABLE		
PROBLEM	PROBABLE CAUSE	SOLUTION
Upon completion of washing, residual solution remains in the wells.	The washer extraction system demonstrates failure.	Verify if the vacuum system is functioning at the appropriate pressure.
	The conducts/pipes of the vacuum system are of a different diameter than that recommended.	Check that the diameter of the channels corresponds to the recommendation by the manufacturer.
	The suction line shows obstructions.	Verify that the vacuum lines are clean.
	The container for storing the waste is full.	Confirm the waste recipient's level.
	The line filter is damp or blocked.	Verify the state and integrity of the suctioning system's filter.
	The needles' points are not placed correctly and do not reach the bottom of the wells.	Examine the placement of the needles' points.
	A different microplate is used in the test.	Verify the type of plate required for the test.
	The washer has not been purged sufficiently.	Check the purging process.
	The operator has not followed the manufacturer's instructions correctly.	Examine the process recommended by the manufacturer. Carry out the required adjustments.
	The plate placed in the washer is incorrectly aligned.	Check the placement of the plate in the washer.
The washing cycle is performing inadequately.	The washing solution reserve is exhausted.	Examine the cleaning solution storage receptacle. Replace the volume missing.
	The washer was not purged sufficiently at the beginning of the work cycle.	Clean adequately in order to homogenize the humidity in each one of its components and to eliminate air bubbles.
	The volume of washing solution distributed has been programmed erroneously.	Verify the required volume for each type of test and for each plate.
	The plate was placed incorrectly in the washer.	Check the correct installation of the plate in the washer.
	The cycle setting was incorrectly selected.	Review the cycle setting recommended for each type of plate.
	The plates used are different from those recommended by the manufacturer.	Verify that the plates used are completely compatible with the washer.
	The fluid level in the wells is inadequate.	
	The washing solution supply tube is not of the diameter or thickness specified by the manufacturer.	Check the manufacturer's specifications. If necessary, correct.
	The pressure is insufficient for delivering the adequate amount of washing solution.	Check the supply system and supply channels, there might be an obstruction in the filling line.
The washing container shows fungal and bacterial growths.	The system is not used frequently.	Check the procedures used for preventing fungal and bacterial growth.
	An adequate control procedure (disinfection) is not used.	Check the procedures used for preventing fungal and bacterial growth.
	The tubes and connectors are not changed with the required frequency.	Verify the change frequency suggested by the manufacturer and or the technical department.
	The washing solution has been contaminated.	Confirm the procedures used in the preparation and management of the washing solution with the aim of determining the cause of contamination and eliminate it.
	Maintenance has not been carried out according to its schedule.	Check the dates planned for carrying out maintenance. Inform those responsible.



## BASIC DEFINITIONS

**Buffer.** A solution containing either a weak acid and its salt or, a weak base and its salt, which makes it resistant to changes in pH at a given temperature.

**PBS.** One of the solutions used to perform washing operations in ELISA tests. PBS is the acronym for Phosphate Buffer Solution. This is made of the following substances:  $NaCl$ ,  $KCl$ ,  $NaHPO_4 \cdot 2H_2O$  and  $KH_2SO_4$ . The manufacturers supply technical bulletins which indicate the proportions and instructions for preparing PBS. In general, one part of concentrated PBS is mixed with 19 parts of deionised water.

**Plate (ELISA).** Consumable with standard dimensions, designed to hold samples and reactions for the ELISA technique. In general, these have 96, 384 or 1536 wells and are made of plastics such as polystyrene and polypropylene. There are plates specially treated to facilitate the performance of the tests.

**Positive displacement pump.** A pump adjusted by a plunger moving along a cylinder. The mechanism is similar to that of a syringe. It is equipped with a set of valves for controlling the flow to and from the pump.

**TMB/ $H_2O_2$ .** (Tetramethylbenzidine/hydrogen peroxide). A set of reagents used for verifying the quality of washing done on the wells used in the ELISA technique.

# Chapter 3



## pH Meter

<b>GMDN Code</b>	<b>15164</b>
<b>ECRI Code</b>	<b>15-164</b>
<b>Denomination</b>	<b>pH Meter</b>

The pH meter is used for determining the concentration of hydrogen ions  $[H^+]$  in a solution. This equipment, provided it is carefully used and calibrated, measures the acidity of an aqueous solution. pH meters are sometimes called pH analysers, pH monitors or potentiometers.

### PURPOSE OF THE EQUIPMENT

The pH meter is commonly used in any field of science related to aqueous solutions. It is used in areas such as agriculture, water treatment and purification, in industrial processes such as petrochemicals, paper manufacture, foods, pharmaceuticals, research and development, metal mechanics, etc. In the health laboratory, its applications are related to the control of culture mediums and to the measurement of the alkalinity or acidity of broths and buffers. In specialized laboratories, diagnostic equipment microelectrodes are used to measure the pH of liquid blood components. The plasma pH allows the patient's health to be evaluated. It normally measures between 7.35 and 7.45. This value relates to the patient's metabolism in which a multitude of reactions occurs where acids and bases are normally kept in balance. Acids constantly liberate hydrogen ions  $[H^+]$  and the organism neutralizes or balances acidity by liberating bicarbonate ions  $[HCO_3^-]$ . The acid-base ratio in the organism is maintained by the kidneys, (organs in which any excesses present are eliminated). The plasma pH is one of the characteristics that vary with factors such as age or state of health of the patient. Table 1 shows typical pH values of some bodily fluids.

### pH values of some bodily fluids

Fluid	pH Value
Bile	7.8 – 8.6
Saliva	6.4 – 6.8
Urine	5.5 – 7.0
Gastric Juice	1.5 – 1.8
Blood	7.35 – 7.45

### PHOTOGRAPH AND COMPONENTS OF THE pH METER

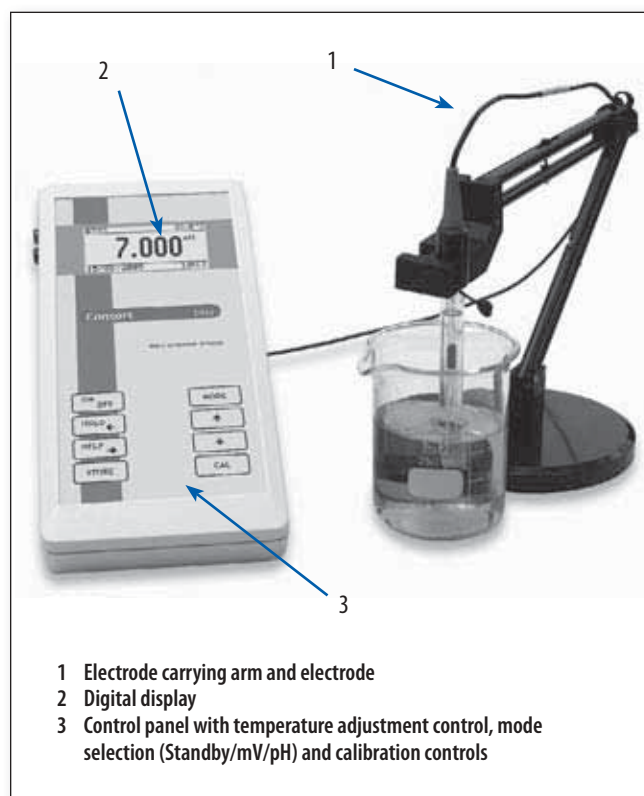

- 1 Electrode carrying arm and electrode
- 2 Digital display
- 3 Control panel with temperature adjustment control, mode selection (Standby/mV/pH) and calibration controls

Photo courtesy of Consort

### OPERATION PRINCIPLES

The pH meter measures the concentration of hydrogen ions  $[H^+]$  using an ion-sensitive electrode. Under ideal conditions, this electrode should respond in the presence of only one type of ion. In reality, there are always interactions or interferences with other types of ions present in the solution. A pH electrode is generally a combined electrode, in which a reference electrode and an internal glass electrode are integrated into a combined probe. The lower part of the probe ends in a round bulb of thin glass where the tip of the internal electrode is found. The body of the probe



contains saturated potassium chloride (KCl) and a solution 0.1 M of hydrogen chloride (HCl). The tip of the reference electrode's cathode is inside the body of the probe. On the outside and end of the inner tube is the anodized end. The reference electrode is usually made of the same type of material as the internal electrode. Both tubes, interior and exterior, contain a reference solution. Only the outer tube has contact with the measured solution through a porous cap which acts as a saline bridge.

This device acts like a galvanized cell. The reference electrode is the internal tube of the pH meter probe, which cannot lose ions through interactions with the surrounding environment. Therefore as a reference, it remains static (unchangeable) during the measuring process. The external tube of the probe contains the medium which is allowed to mix with the external environment. As a result, this tube must be filled periodically with a potassium chloride solution (KCl) for restoring the capacity of the electrode which would otherwise be inhibited by a loss of ions and evaporation.

The glass bulb on the lower part of the pH electrode acts as a measuring element and is covered with a layer of hydrated gel on its exterior and interior. Metallic sodium cations  $[Na^+]$  are diffused in the hydrated gel outside of the glass and in the solution, while the hydrogen ions  $[H^+]$  are diffused in the gel. This gel makes the pH electrode ion-selective: Hydrogen ions  $[H^+]$  cannot pass through the glass membrane of the pH electrode. Sodium ions  $[Na^+]$  pass through and cause a change in free energy, which the pH meter measures. A brief explanation of the theory on how electrodes function is included in the appendix at the end of the chapter.

### pH METER COMPONENTS

A pH meter generally has the following components:

1. **The body of the instrument containing the circuits, controls, connectors, display screens and measuring scales.** The following are among some of its most important components:

- a) **An ON and OFF switch.** Not all pH meters have an on and off switch. Some simply have a cord with a plug which allows it to be connected to a suitable electrical outlet.
- b) **Temperature control.** This control allows adjustments according to the temperature of the solution measured.
- c) **Calibration controls.** Depending on the design, pH meters possess one or two calibration buttons or dials. Normally these are identified by **Cal 1** and **Cal 2**. If the pH meter is calibrated using only one solution, the Cal 1 button is used; making sure that Cal 2 is set at a 100%. If the pH meter allows two point calibrations, two known pH solutions covering the range of pH to be measured are used. In this case, the two controls are used (Cal 1 and Cal 2). In special cases, a three-point calibration must be done (using three known pH solutions).
- d) **Mode selector.** The functions generally included in this control are:
  - I. **Standby mode (0).** In this position the electrodes are protected from electrical currents. It is the position used for maintaining the equipment while stored.
  - II. **pH mode.** In this position the equipment can take pH measurements after performing the required calibration procedures.

Figure 4. Diagram of a pH meter

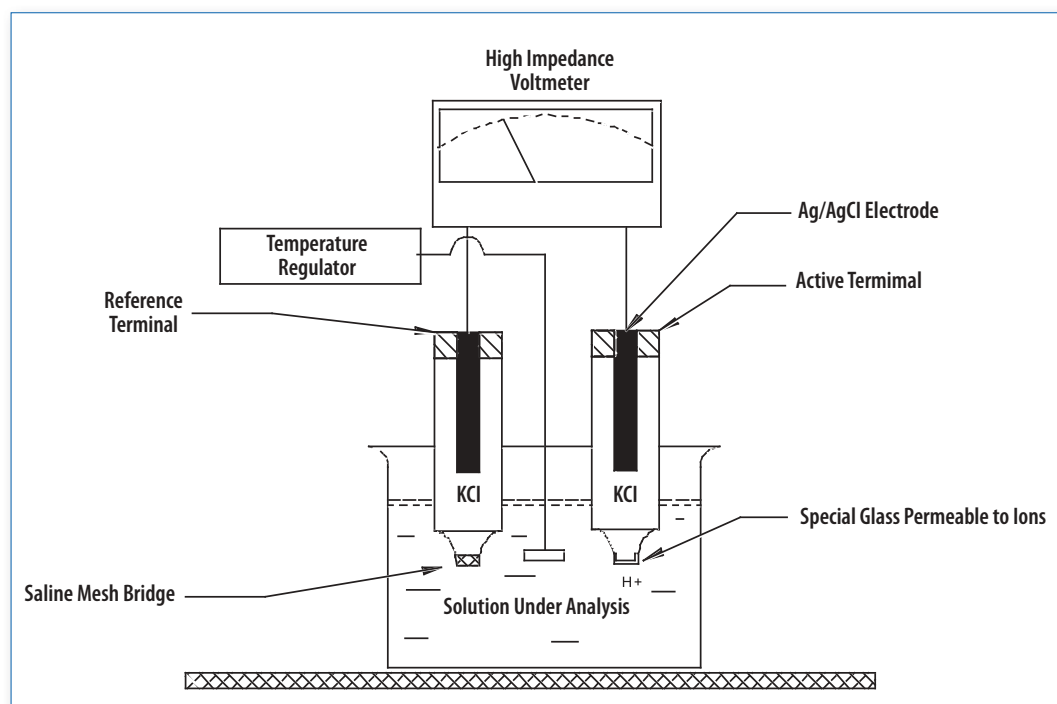

III. **Millivolt mode (mV).** In this position the equipment is capable of performing millivoltage readings.

IV. **ATC mode.** The automatic temperature control mode is used when the pH is measured in solutions for which the temperature varies. This function requires the use of a special probe. Not all pH meters have this control.

2. **A combined electrode or probe.** This device must be stored in distilled water and stay connected to the measuring instrument. A combination electrode has a

reference electrode (also known as *Calomel* electrode) and an internal electrode, integrated into the same body. Its design varies depending on the manufacturer.

**TYPICAL CIRCUIT**

Figure 6 features a typical circuit adapted to the control system of the pH meter. Each manufacturer has its own designs and variations.

**Figure 5. Types of electrodes**

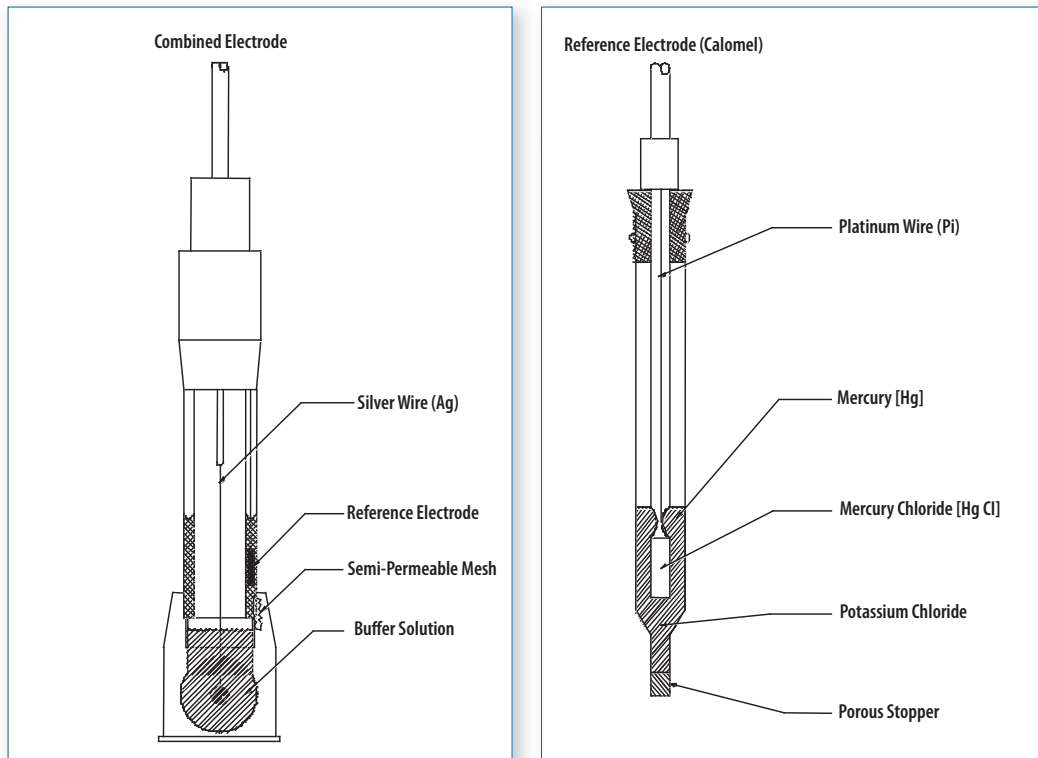

**Figure 6. Example of a typical pH meter control circuit**

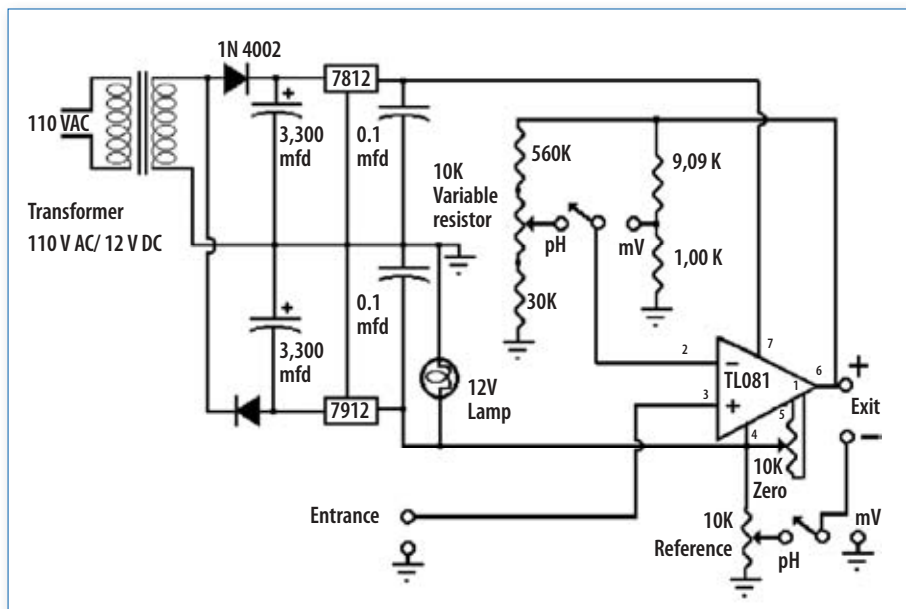

## Description of typical control circuit elements

System	Element	Description
Electric feeding and correction.	110 V/12 V AC transformer.*	A device converting the voltage of the 110 V to 12 V AC network.
	1N4002 rectifier diodes.	Diode controlling the type of wave and guaranteeing that is positive.
	Electrolyte condensers 3300 microfarads ( $\mu\text{fd}$ ) (2).	Condensers absorbing the DC voltage to the diodes.
	Tri terminal regulators (7812, 7912).	A device regulating the voltage resulting from the interaction between diodes and condensers.
	0.1 microfarad ( $\mu\text{fd}$ ) (2) electrolyte condensers.	Devices used to achieve stability at high frequency.
	12 V D C signal light.	Light indicating if the equipment is ON.
Measurement of pH and millivolts.	TL081 non-inverted type dual amplifier.	Millivolts circuits.
	(R1) 9.09 K $\Omega$ (ohm) resistors.	
	(R2) 1 K $\Omega$ (ohm) resistors.	pH circuits.
	(R3) 560 K $\Omega$ (ohm) resistors.	
	(R4) 10 K $\Omega$ (ohm) variable resistors.	
	(R5) 30 K $\Omega$ (ohm) resistors.	Ground resistance.
	The circuit gain is governed by means of the following equation: Gain = $1 + (R3 + P \times R4) / R5 + (1 - P) \times R4$ .	
Outlet section.	Low cost DC voltmeter.	Permits readings in millivolts. The voltage read is 10 times that of the cell, allowing a resolution of 0.1 millivolts.
		The reading is done by using carbon/quinhydrone electrodes.

\* Different voltage specifications are applicable in certain regions of the World.

## INSTALLATION REQUIREMENTS

The pH meter works using electric current with the following characteristics.

Power: Single phase Voltage: 110 V or 220-230 V Frequencies; 50-60 Hz depending on the World region.

There is also portable pH meters powered with batteries.

## GENERAL CALIBRATION PROCEDURE

pH analyzers must be calibrated before use to guarantee the quality and accuracy of the readings following these procedures:

1. **One point calibration.** This is carried out for normal working conditions and for normal use. It uses one known pH reference solution.
2. **Two point calibration.** This is done prior to performing very precise measurements. It uses two known pH reference solutions. It is also done if the instrument is used sporadically and its maintenance is not carried out frequently.

## Description of the process

### Frequency: Daily

1. **Calibrate the pH meter using one known pH solution (one point calibration).**
  - 1.1 Connect the equipment to an electrical outlet with suitable voltage.
  - 1.2 Adjust the temperature selector to the environmental temperature.
  - 1.3 Adjust the meter.
  - 1.4 Remove the electrodes from the storage container. The electrodes must always be stored in a suitable solution. Some can be maintained in distilled water, others must be kept in a different solution as their manufacturers recommend<sup>1</sup>. If for some reason, the electrode becomes dry, it is necessary to soak it for at least 24 hours before use.
  - 1.5 Rinse the electrode with distilled water in an empty beaker.
  - 1.6 Dry the electrode with material able to absorb residual liquid on its surface, without impregnating the electrode. To avoid possible contamination, the electrodes must be rinsed between different solutions.

<sup>1</sup> Verify the type of buffer solution recommended by the electrode manufacturer.

## 2. *Place electrodes in the calibration solution.*

- 2.1 Submerge the electrode in the standardization solution in such a manner that its lower extremity does not touch the bottom of the beaker. This decreases the risk of breaking the electrode. If the test requires that the solution be kept in motion using the magnetic agitator, special care must be taken so that the agitation rod does not hit the electrode as this could break it. Buffer solution is used as a calibration solution, because its pH is known and therefore will still be maintained even if a little contamination occurs. In general, a solution of pH = 7 is used for this purpose<sup>1</sup>.

## 3. *Turn the functions selector from Standby position to pH position.*

- 3.1 This action connects the electrode to the pH measuring scale in the pH meter.
- 3.2 Adjust the meter to read the pH of the calibration solution using the button marked Cal 1. This enables the meter to read the pH of the calibration solution.

For example: For a solution at pH = 7, the needle can oscillate slightly in units of 0.1 pH; on average, the reading should be 7. The reading of the meter (reading scale) should be done perpendicularly, to avoid or eliminate parallel-type errors (reading errors produced by the shadow of the meter's needle, visible on the mirror of the reading scale). The pH meter is then ready (calibrated), to carry out the correct pH readings.

- 3.3. Put the functions selector in the Standby position.

## 4. *Measuring the pH of a solution.*

- 4.1 Remove the electrode from the calibration solution.
- 4.2 Rinse the electrode with distilled water and dry it.
- 4.3 Place the electrode in the solution of unknown pH.
- 4.4 Turn the functions selector from the Standby position to the pH position.
- 4.5 Read the pH of the solution on the meter's scale or the screen. Register the reading obtained on the control sheet.
- 4.6 Turn the functions selector again to the Standby position.

If it is necessary to measure the pH of more than one solution, repeat the previously described procedures, rinsing the probe with distilled water and drying with clean, lint-free paper between readings. When the pH has to be measured

in numerous solutions, the pH meter must be calibrated frequently, following the steps previously described.

## 5. *Turn off the pH meter.*

- 5.1 Remove the electrode from the last solution analyzed.
- 5.2 Rinse the electrode in distilled water and dry it with a drying material that will not penetrate it.
- 5.3 Place the electrode in its storage container.
- 5.4 Verify that the functions selector is in the Standby position.
- 5.5 Activate the off switch or disconnect the feed cable, if it lacks this control.
- 5.6 Clean the work area.

## GENERAL MAINTENANCE OF THE pH METER

pH meters have two general maintenance procedures: one concerning the analyzer's body, the other for the pH detection probe (electrodes).

### General maintenance procedures for the pH meter's body

#### Frequency: Every six months

1. Examine the exterior of the equipment and evaluate its general physical condition. Verify the cleanliness of the covers and their adjustments.
2. Test the connection cable and its system of connections. Check that they are in good condition and clean.
3. Examine the equipment controls. Verify that these are in good condition and activated without difficulty.
4. Verify that the meter is in good condition. To do this, the instrument must be disconnected from the electric feed line. Adjust the indicator needle to zero (0) using the adjustment screw generally found below the pivot of the indicator needle. If the equipment has an indicator screen, check that it is functioning normally.
5. Confirm that the on indicator (bulb or diode) operates normally.
6. Verify the state of the electrode carrying arm. Examine the electrode attachment and assembly mechanism to prevent the electrode from becoming loose. Check that the height adjustment operates correctly.
7. Check the batteries (if applicable); change them if necessary.
8. Test its function by measuring the pH of a known solution.
9. Inspect the ground connection and check for escaping current.

<sup>1</sup> Verify the type of calibration solution recommended by the electrode manufacturer.

## BASIC MAINTENANCE OF THE ELECTRODE

### Frequency: Every four months

The measuring or detector electrode requires periodic maintenance of the conducting solution to obtain precise readings.

The recommended steps for replacing the electrolyte solution are the following:

1. Remove the detector electrode from the storage buffer solution.
2. Rinse the detector electrode abundantly with distilled water.
3. Remove the upper cover of the detector electrode.
4. Fill the conduit surrounding the internal electrode with a saturated potassium chloride (KCl) solution. Use the syringe or applicator supplied with the KCl solution. Verify that the tip of the syringe does not touch the inside of the electrode.
5. Close the electrode with its cover. Rinse the electrode in distilled water.
6. Keep the electrode in storage buffer solution while not in use.

### Cleaning of the electrode

The type of cleaning required for electrodes depends of the type of contaminant affecting it. The most common procedures are summarized next:

1. **General cleaning.** Soak the pH electrode in a 0.1 M HCl solution or 0.1 M HNO<sub>3</sub>, for 20 minutes. Rinse with water.

2. **Removal of deposits and bacteria.** Soak the pH electrode in a diluted domestic bleach solution (e.g. 1%), for 10 minutes. Rinse abundantly with water.
3. **Cleaning oil and grease.** Rinse the pH electrode with a mild detergent or with methyl alcohol. Rinse with water.
4. **Cleaning of protein deposits.** Soak the pH electrode in 1% pepsin and 0.1 M HCl for 5 minutes. Rinse with water.

After carrying out each cleaning operation, rinse with deionised water and refill the reference electrode before use.

### Other precautionary measures

1. Do not strike the electrode. Given that the structure is generally made of glass and very fragile, it is necessary to manipulate it very carefully, preventing it from being knocked off.
2. Remember that the electrode has a limited lifespan.
3. While not in use, keep the electrode inside the storage buffer solution.

## TROUBLESHOOTING TABLE

PROBLEM	PROBABLE CAUSE	SOLUTION
The pH meter shows unstable readings.	There are air bubbles in the electrode.	Soak the electrode to eliminate the bubbles.
	The electrode is dirty.	Clean the electrode and recalibrate.
	The electrode is not immersed.	Verify that the sample covers the tip of the electrode perfectly.
	The electrode is broken.	Replace the electrode.
The electrode's response is slow.	The electrode is dirty or greasy.	Clean the electrode and recalibrate.
The screen shows an error message.	Incorrect operating mode selected.	Verify the operation mode selected. Select a valid operation.
The screen shows a calibration or error message.	There is a calibration error.	Recalibrate the pH meter.
	The calibration of the buffer value is erroneous.	Verify the buffer values used.
	The electrode is dirty.	Clean and calibrate the electrode.
The pH meter is on, but there is no signal on the screen.*	The batteries are badly installed.	Verify the polarity of the batteries.
	The batteries are worn out.	Replace the batteries.
The battery indicator is flashing.*	The batteries are worn out.	Replace the batteries.

\* Applicable to equipment equipped with batteries only.

## BASIC DEFINITIONS

**Buffer.** A solution containing either a weak acid and its salt or, a weak base and its salt, which makes it resistant to changes in pH at a given temperature.

**Calomel electrode.** A reference electrode used with the active electrode for determining the pH of a solution. This electrode is constructed with a mercury base (Hg), a covering of dimercuric chloride ( $\text{Hg}_2\text{Cl}_2$ ) and a potassium chloride solution of 0.1 M. It is represented as  $\text{Cl}_2[\text{Hg}_2\text{Cl}_2, \text{KCl}]\text{Hg}$ .

**Dissociation.** A phenomenon through which a break in the molecules occurs. As a result it produces electrically charged particles (ions).

**Electrolyte.** A solute which produces a conducting solution, e.g. NaCl (sodium chloride) and  $\text{NH}_4\text{OH}$ .

**Gel.** A semisolid substance (e.g. jelly) composed of a colloid (solid) dispersed in a liquid medium.

**Ion.** Neutral atom which gains or loses an electron. When the atom loses an electron, it becomes a positively charged ion, called a cation. If the atom gains or captures an electron, it becomes a negatively charged ion, called an anion.

**Ion-sensitive electrode.** A device which produces a difference in potential proportional to the concentration of an analyte.

**Molarity.** Number of Moles (M) in a substance in a litre of solution. (Number of moles of solute in a litre (L) of solution). The brackets around the ionic symbol indicate that it is treated as a molar concentration.

**Mol. (abbreviation for molecule).** A quantity of any substance whose mass expressed in grams is numerically equal to its atomic mass.

**Mole (unit).** The amount of a substance that contains as many atoms, molecules, ions, or other elementary units as the number of atoms in 0.012 kilogram of carbon 12. It corresponds to the number  $6.0225 \times 10^{23}$ , or Avogadro's number, also called gram molecule. The mass in grams of this amount of a substance, numerically equal to the molecular weight of the substance, also called *gram-molecular weight*.

**pH.** Measurement of the concentration of the hydrogen ion ( $\text{H}^+$ ) given in moles per litre (M) in a solution. The pH concept was proposed by Sørensen and Lindstrøm-Lang in 1909 to facilitate expressing very low ion concentrations. It is defined by the following equation:  
 $\text{pH} = -\log [\text{H}^+] \quad \text{or} \quad [\text{H}^+] = 10^{-\text{pH}}$

It measures the acidity of a solution. Example, in water the concentration of  $[\text{H}^+]$  is  $1.0 \times 10^{-7}$  M resulting in  $\text{pH} = 7$ . This allows the range of concentrations from  $1$  to  $10^{-14}$  M, to be expressed from zero (0) to 14. There are diverse systems for measuring the acidity of a solution. An acidic substance dissolved in water is capable of producing  $\text{H}^+$  ions. A basic substance dissolved in water is capable of producing  $[\text{OH}^-]$  (hydroxides) ions.

An acid substance has a greater quantity of ions  $[\text{H}^+]$  than pure water; a basic substance shows greater quantities of ions  $[\text{OH}^-]$  than pure water. The concentrations of substances are expressed in moles per litre.

In pure water, the ion concentration  $[\text{H}^+]$  and  $[\text{OH}^-]$  is  $1.0 \times 10^{-7}$  M, it is thus considered a neutral substance. In reality, it is a weak electrolyte that is dissociated following the following equation:  
 $\text{H}_2\text{O} \rightleftharpoons [\text{H}^+][\text{OH}^-]$

In all aqueous solutions there is a balance expressed as:

$$\frac{[\text{H}^+][\text{OH}^-]}{\text{H}_2\text{O}} = K$$

If the solution is diluted, the concentration of the non-dissociated water can be considered constant:

$$[\text{H}^+][\text{OH}^-] = [\text{H}_2\text{O}]K = K_a$$

The new constant  $K_a$  is called a constant of dissociation or ionic product of water and its value is  $1.0 \times 10^{-14}$  at  $25^\circ\text{C}$ .

$$[\text{H}^+][\text{OH}^-] = 1.0 \times 10^{-14}$$

$$X \times X = 1.0 \times 10^{-14}$$

$$X^2 = 1.0 \times 10^{-14}$$

$$X = 1.0 \times 10^{-7}$$

In pure water the concentrations of  $\text{H}^+$  and  $\text{OH}^-$  are  $1.0 \times 10^{-7}$  M, a very low concentration, given that the molar concentration of water is 55.4 mol/litre.

**Solution.** Homogenous liquid mixture (with uniform properties) of two or more substances. It is characterized by the absence of chemical reactions among the components in the mixture. The component in greater proportion and generally in a liquid state is called solvent and that or those in a lesser quantity, the solutes.



## Annex

## The pH theory

pH electrodes ideally behave as an electrochemical cell and react to the concentration of ions  $[H^+]$ . This generates an electromotive force (EMF) which, according to the Nernst law is calculated using the following equation:

$$E = E^\circ + \frac{RT}{nF} \ln a_{H^+}$$

Given that:

$$pH = -\ln a_{H^+} \text{ where } a \text{ is the effective concentration of ions (Activity)}$$

If  $n = 1$ , the equation is then rewritten as:

$$E = E^\circ - \frac{R'T}{F} pH$$

$E^\circ$  is a constant dependant on the temperature. If  $E^\circ$  is substituted by  $E'T$ , the calibration will be more sensitive. Real electrodes do not always perform according to the Nernst equation. If the concept of sensibility ( $s$ ) is introduced, the equation can be rewritten as:

$$E = E'T - s \frac{R'T}{F} pH$$

The values of  $E'$  and  $s$  are found when measuring the EMF in two solutions with known pH.  $S$  is the slope of  $E$  versus pH, while  $E'$  is found at the intersection with the axis y. When  $E'$  and  $s$  are known, the equation can be rewritten and the pH can be calculated as:

$$pH = \frac{E'T - E}{s \frac{R'T}{F}}$$

# Chapter 4



## Balances

<b>GMDN Code</b>	<b>10261</b>	<b>10263</b>	<b>45513</b>	<b>46548</b>
<b>ECRI Code</b>	<b>10-261</b>	<b>10-263</b>	<b>18-449</b>	<b>18-451</b>
<b>Denomination</b>	<b>Balances</b>	<b>Electronic balances</b>	<b>Analytical electronic balances</b>	<b>Micro analytical, microelectronic balances</b>

The balance is an instrument which measures the mass of a body or substance using the gravity force which acts on that body. The word comes from the Latin terms *bis* which means two and *lanx*, plate. The balance has other names such as scale and weight. It must be taken into account that the weight is the force which the gravitational field exercises

on a body's mass, this force being the product of the mass by the local acceleration of gravity [ $F = m \times g$ ]. The term local is used to emphasize that this acceleration depends on factors such as the geographical latitude, altitude and the Earth's density where the measurement is taken. This force is measured in Newtons.

### PHOTOGRAPHS OF BALANCES

#### Mechanical balance



Photo courtesy of Ohaus Corporation

#### Electronic balance



Photo courtesy of Acculab Corporation



## PURPOSE OF THE BALANCE

The balance is used for measuring the mass of a body or substance or its weight. In the laboratory, the balance is used for weighing as part of quality control activities (on devices like pipettes), in the preparation of mixtures of components in predefined proportions and in the determination of specific densities or weights.

## OPERATION PRINCIPLES

There are differences in design, principles and criteria of metrology amongst balances. At present, there are two large groups of balances: mechanical and electronic balances.

### Mechanical balances

The following are some of the more common ones:

1. **Spring balance.** Its function is based on a mechanical property of springs as the force exercised on a spring is proportional to the spring's elasticity constant  $[k]$ , multiplied by its elongation  $[x]$   $[F = -kx]$ . The greater the mass  $[m]$  placed on the balance's plate, the greater the elongation will be, given that the elongation is proportional to the mass and the spring's constant. The calibration of a spring balance depends on the force of gravity acting on the object weighed. This type of balance is used when great precision is not necessary.
2. **Sliding weight balance.** This type of balance is equipped with two known weights which can be moved on setting scales (one macro, the other micro). Upon placing a substance of unknown mass on the tray, its weight is determined by moving the weight on both setting scales until the equilibrium position is reached. At this point, the weight is obtained by adding both quantities indicated by the sliding masses' position on the scale.
3. **Analytical balance.** This balance functions by comparing known weight masses with that of a substance of unknown weight. It is composed of a base on a bar or symmetrical lever, maintained by a blade-like support on a central point called a fulcrum. At its ends, there are stirrups, also supported with blades which allow these to oscillate smoothly. From there, two plates are suspended. Certified weights are placed on one of the plates and unknown weights on the other. The balance has a securing system or lock, which allows the main lever to remain stable when not in use or when it is necessary to modify the counter-weights. The balance is inside an external box which protects it from interferences, such as air currents. Analytical balances can weigh ten thousandths of a gram (0.0001 g) or 100 thousandths of a gram (0.00001 g). This type of balance generally has a capacity of up to 200 grams.

Figure 7. Spring balance

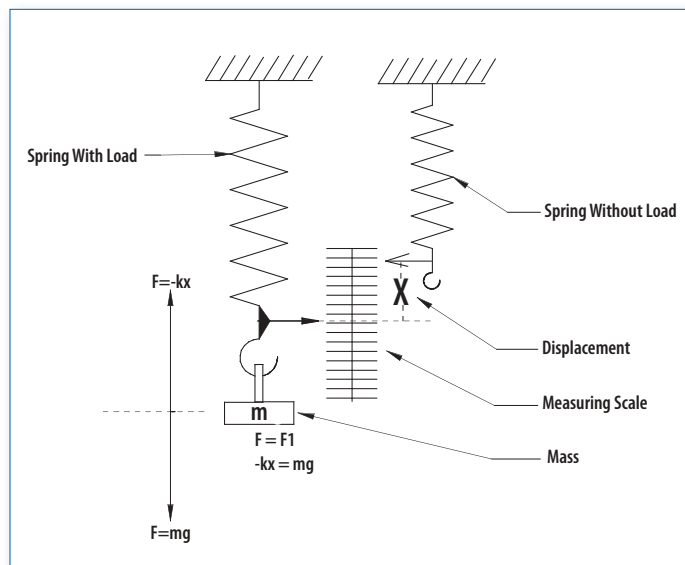

Figure 8. Sliding weight scale

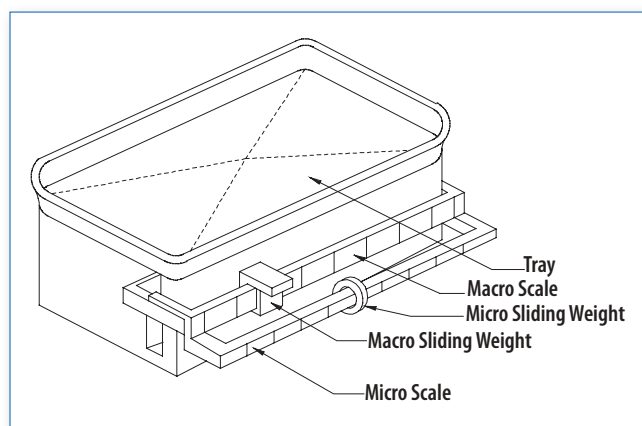
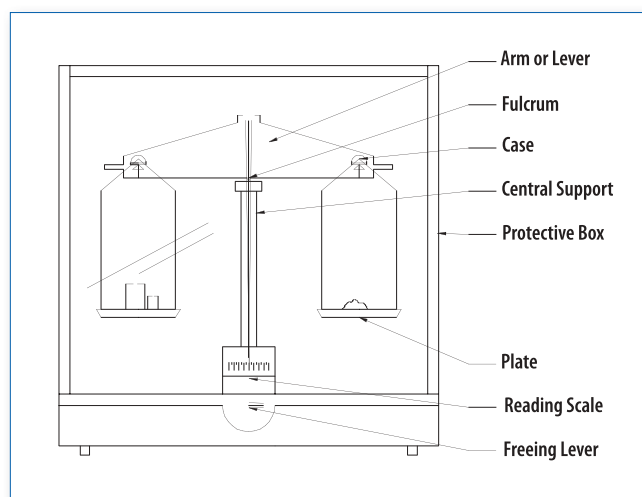

Figure 9. Analytical balance



It is necessary to have a set of certified masses. The set is generally composed of the following pieces:

Type of mass	Capacity
Simple pieces	1, 2, 5, 10, 20, and 50 g
	100, 200 and 500 g
Fractional pieces	2, 5, 10, 20 and 50 mg
	100, 200 and 500 mg

4. **Upper plate balance (Top loading or parallel guidance balance).** This type of balance has a loading plate located on its upper part, supported by a column maintained in a vertical position by two pairs of guides with flexible connections. The effect of the force produced by the mass is transmitted from a point on the vertical column directly or by some mechanical means to the loading cell. The requirement with this type of mechanism is that parallel guides must be maintained with exactitude of up to  $\pm 1 \mu\text{m}$ . Deviations in parallelism cause an error known as lateral load (when the mass being weighed shows differences if the reading is taken at the centre of the plate or on one of its sides). The diagram shown below explains the operation principle some manufacturers have introduced in electronic balances.

5. **Substitution Balance (Unequal-lever arm or two-knife balance).** This is a balance with a single plate. An unknown mass is placed on the weighing plate. It is weighed by removing known masses from the counterweight side until it reaches a balanced position, using a mechanical system of cams. The fulcrum is generally off-centre in relation to the length of the load beam and located near the front of the balance. When a mass is placed on the weight plate and the balance's locking mechanism is released, the movement of the load beam is projected through an optical system to a screen located on the front part of the instrument.

### Operation verification

The procedure used for verifying the functioning of a typical mechanical balance is described below. The described process is based on the substitution balance.

1. Verify that the balance is levelled. The levelling is achieved using a ring-shaped adjustment mechanism located on the base of the balance or by adjusting a bubble or knob on a scale located on the front of the balance's base.
2. Test the zero mechanism. Place the controls on zero and free the balance. If the reading does not stay at zero, adjust the zero mechanism (a grooved screw located in a horizontal position near the fulcrum). To do this, it is necessary to block the balance and slightly adjust the mechanism. The process is to be continued until the zero adjusts correctly on the reading scale.

Figure 10. Upper plate balance

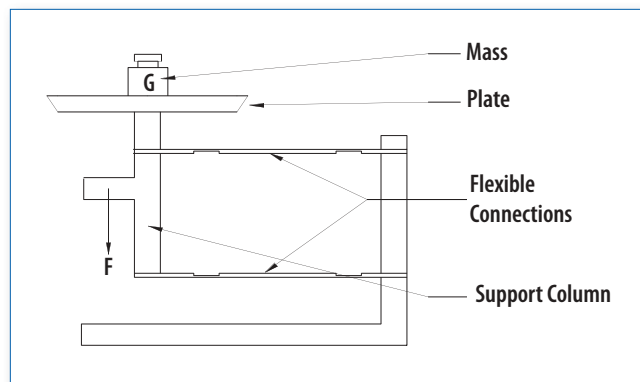
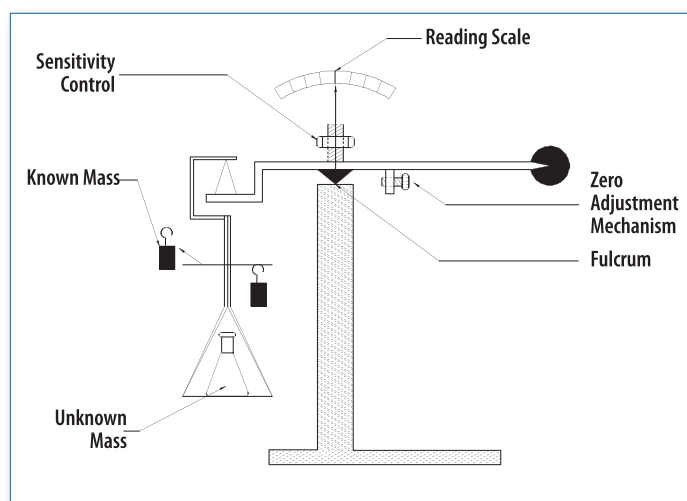

Figure 11. Substitution balance



3. Verify and adjust the sensitivity. This is always readjusted whenever some internal adjustment is done. It is performed with a known standard according to the following steps:
  - a) Lock the balance.
  - b) Place a standard weight (equivalent to the optical scale range) on the plate.
  - c) Position the micro setting to one (1).
  - d) Release the balance.
  - e) Adjust to the zero position.
  - f) Position the micro setting to zero (0). The balance should indicate 100. If the scale displays less or more than 100, the sensitivity control must be adjusted. This requires locking the balance, opening the upper cover and turning the sensitivity screw: If the scale registers more than 100; turn the screw in a clockwise position. If the scale registers less than 100, it is necessary to unwind the screw anticlockwise. Repeat the process until the balance is adjusted (adjusting the zero and the sensitivity).

- Verify the plate's brake. It is mounted on a threaded axis which touches the plate in order to prevent it from oscillating when the balance is locked. In case of an imbalance, the axis must be rotated slightly until the distance between the brake and the plate is zero when the balance is locked.

**Maintenance of the mechanical balance**

The maintenance of mechanical balances is limited to the following routines:

**Frequency: Daily**

- Verify the level.
- Verify the zero setting.
- Verify the sensitivity adjustment.
- Clean the weighing plate.

**Frequency: Annually**

- Calibrate the balance and document the process.
- Disassemble and clean the internal components. This must be done according to the process outlined by the manufacturer or a specialized firm must be contracted to do so.

**Electronic balances**

The electronic balances have three basic components:

- A weighing plate. The object to be weighed placed on the weighing plate exercises a pressure distributed randomly over the surface of the plate. By means of a transfer mechanism (levers, supports, guides), the weight's load is concentrated on a simple force [F] which can be measured.  $[F = \int P \partial a]$ . The pressure's integral part on the area allows the force to be calculated.
- A measuring device known as "load cell" produces an exit signal corresponding to the load's force in the form of changes in the voltage or frequency.
- A digital analogous electronic circuit shows the final result of the weight digitally.

Laboratory balances operate according to the principle of compensation of the electromagnetic force applicable to displacements or torques. The combination of their mechanical components and automatic reading systems provides weight measurements at defined levels of accuracy depending on the model.

**Principle.** The mobile parts (weighing plate, support column [a], bobbin, position and load indicator [G] -the object in the process of being weighed-) are maintained in equilibrium by a compensation force [F] equal to the weight. The compensation force is generated by an electrical current through a bobbin in the air gap of a cylindrical electromagnet. The force F is calculated with the equation  $[F = I \times L \times B]$  where: I = electrical intensity, L = total length of the wire of the coil and B = magnetic flow intensity in the electromagnet's air gap.

With any change in the load (weight/mass), the mobile mechanical system responds by moving vertically a fraction of distance. Detected by a photosensor [e], an electrical signal is sent to the servo-amplifier [f]. This changes the flow of electrical current passing through the bobbin of the magnet [c] in such a manner that the mobile system returns to the balanced position upon adjusting of the magnetic flow in the electromagnet. Consequently, the weight of the mass [G] can be measured indirectly at the start of the electrical current flow, which passes through the circuit measuring the voltage [V] by means of a precision resistor [R],  $[V = I \times R]$ . To date, many systems developed use the electronic system for carrying out very exact measurements of mass and weight. The following diagram explains how electronic balances function.

Figure 12. Components of electronic balances

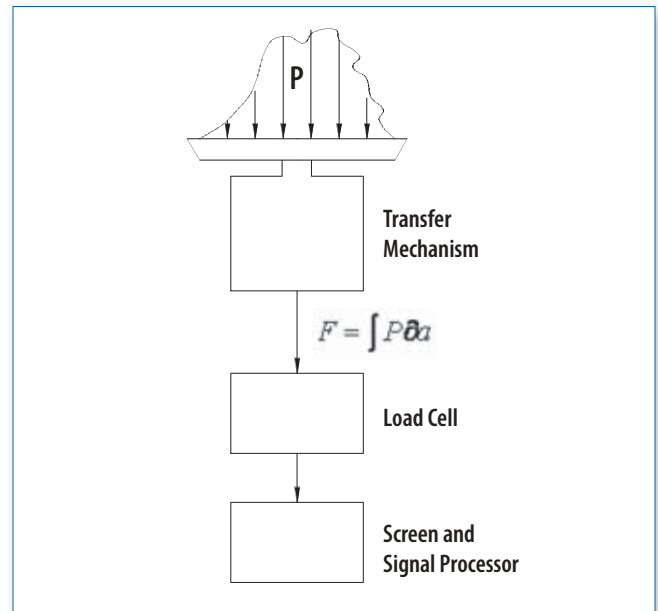
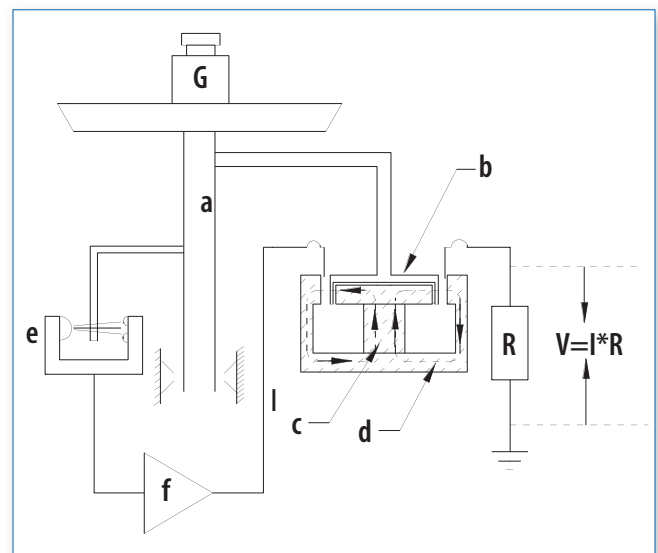

Figure 13. Compensation force principle



### The signal processing system

The signal processing system is composed of the circuit which transforms the electrical signal emitted by the transducer into numerical data which can be read on a screen. The signal process comprises the following functions:

1. **Tare setting.** This setting is used to adjust the reading value at zero with any load within the balance's capacity range. It is controlled by a button generally located on the front part of the balance. It is commonly used for taring the weighing container.
2. **Repeatability setting control.** During a reading, weighed values are averaged within a predefined period of time. This function is very useful when weighing operations need to be carried out in unstable conditions, e.g. in the presence of air currents or vibrations. This control defines the time period allowed for a result to lie within preset limits for it to be considered stable. In addition, it can be adjusted to suit a particular application.
3. **Rounding off.** In general, electronic balances process data internally at a greater resolution than shown on the screen. The internal net value rounded off is displayed on the screen.
4. **Stability detector.** This light indicator fades when the weighing result becomes stable and is ready to be read. Alternatively in other balance models, this feature allows the display of the result on the screen when the measure of the weight becomes stable.
5. **Electronic signalling process.** It allows the processing and display of the weighing operation results. It may also allow other special functions such as piece counting, percentage weighing, dynamic weighing of unstable weight (e.g. animals), and formula weighing, among others. The calculations are done by the microprocessor following the instructions entered by the operator on the balance's keyboard.

### Classification of balances

The International Organization of Legal Metrology (OIML) has classified the balances into four groups:

- Group I: special exactitude
- Group II: high exactitude
- Group III: medium exactitude
- Group IV: ordinary exactitude

The graph in Figure 14 shows the above-mentioned classification.

In the metrological classification of electronic balances, only two parameters are of importance:

1. The maximum load [Max.]
2. The value of the digital division [d]<sup>1</sup>

Figure 14. Classification of balances by exactitude

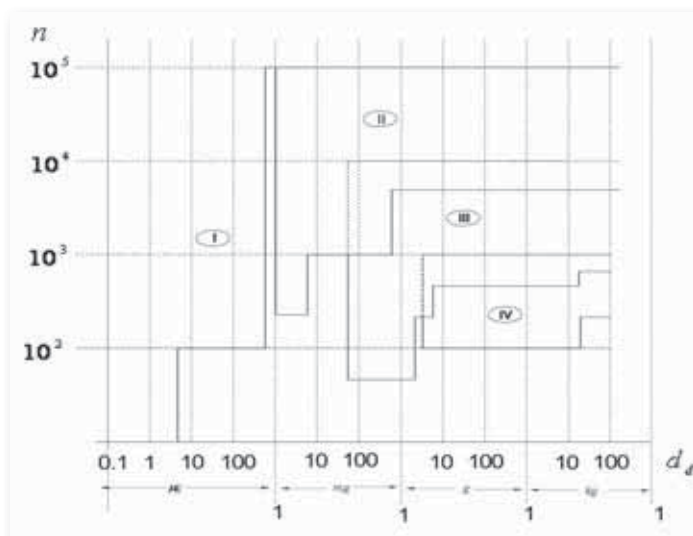

The number of the scale's divisions is calculated by means of the following formula.

$$n = \frac{\text{Max}}{d_d}$$

The OIML accepts the following convention for laboratory balances.

1. Ultramicroanalytics  $d_d = 0.1 \mu\text{g}$
2. Microanalytics  $d_d = 1 \mu\text{g}$
3. Semi-microanalytics  $d_d = 0.01 \text{ mg}$
4. Macroanalytics  $d_d = 0.1 \text{ mg}$
5. Precision  $d_d \geq 1 \text{ mg}$

<sup>1</sup> Kupper, W., Balances and Weighing, Mettler Instrument Corp., Princeton-Hightstown, NJ.

### Electronic balance controls

A diagram of the typical controls on a modern electronic balance is shown in Figure 15. From this diagram it is necessary to point out the following:

1. Numerous functions are incorporated.
2. Various measuring units can be selected.
3. It is possible to know the day and hour when the measurements were taken.
4. The processes done can be documented and printed.
5. It is possible to select the language.

### INSTALLATION REQUIREMENTS

For the satisfactory installation and use of a balance, the following is required:

1. An environment with no air currents or sudden changes in temperature and free from dust.
2. A perfectly levelled table/counter. A platform of high inertia, isolated from the structures located in its vicinity is ideal to reduce the effect of vibrations from certain equipment such as centrifuges and refrigerators. There must be a large enough area for installing the balance and any auxiliary equipment needed during the weighing processes. Likewise, the space required for cables such as the interconnection, electrical current cables and the information system connection to the printer must be anticipated.
3. Avoid installing equipment which produces elevated magnetic fields or vibrations like centrifuges, electrical motors, compressors and generators in its vicinity.
4. Avoid locating it directly under the air-conditioning system (air currents) and sunlight.
5. An electrical outlet which complies with the current electrical standards in the country or the laboratory. It must be in good condition and equipped with a ground pole and switches.

### Electronic balance operation

The operation of a modern electronic balance is clearly detailed in its operator's manual from the manufacturer. In general, it must conform to the following procedure:

1. Allow the balance to equilibrate with the environment where it is installed.
2. Allow the balance to warm-up before initiating activities. Normally it is sufficient to have it connected to the electrical feed system. Some manufacturers suggest at least 20 minutes from the moment it is energized until use. Analytical balances Class 1 require at least 2 hours for warming before initiating use.

Verify that the balance is calibrated. Electronic balances generally have a factory-made calibration stored in memory which can be used if it does not have calibration masses. If calibration is required, use calibrated masses as indicated by the manufacturer. The calibrated masses must conform or exceed the ASTM tolerances. For general information, the following table shows the accepted tolerance for the ASTM Class 1<sup>1</sup> masses.

Weight (grams)	Higher limit (g)	Lower limit (g)
100	100.0003	99.9998
200	200.0005	199.9995
300	300.0008	299.9993
500	500.0013	499.9988
1 000	1000.0025	999.9975
2 000	2000.0050	1999.9950
3 000	3000.0075	2999.9925
5 000	5000.0125	4999.9875

3. Follow the instructions indicated in the manufacturer's operations manual.

Figure 15. Analytical balance control panel

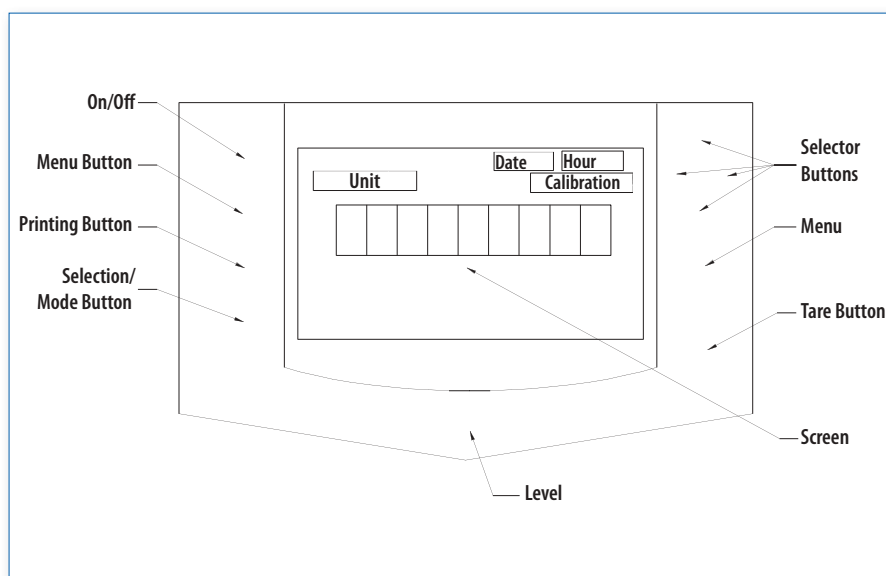

### Calibration of balances

The calibration of balances must be done by personnel specially trained for this activity. It should be highlighted that it must be done based on the alignments of the OIML or an equivalent body such as the American Society for Testing and Materials (ASTM), institutions which have developed methodologies for classifying standard weights. The reference weights classification used by the OIML is covered in the table opposite.

<sup>1</sup> Field Services Handbook for High Precision Scales, IES Corporation, Portland, Oregon, 2004.

Table of OIML reference weights classification<sup>1</sup>

Class	Description	Tolerance	Uncertainty allowed	Frequency of recalibration
E1	Stainless steel weights without marks or adjusting cavity.	± 0.5 ppm per kg	± 1/3 of the tolerance	2 years
E2	Stainless steel weights without marks or adjusting cavity.	± 1.5 ppm per kg	± 1/3 of the tolerance	2 years
F1	Stainless steel weights with screw button for protecting the adjusting cavity.	±5 ppm per kg	± 1/5 of the tolerance	1 year
F2	Bronze plated weights.	± 15 ppm per kg	± 1/5 of the tolerance	1 year
M1	Bronze weights (that do not corrode or become stained) or of cast iron weights with a high quality paint finish.	± 50 ppm per kg	± 1/5 of the tolerance	1 year
M2	Bronze or cast iron weights (commercial weights).	±200 ppm per 1 kg	± 1/5 of the tolerance	1 year

Table of standard weights' use according to the balance's capacity

Capacity	Resolution							
	100 g	10 g	1 g	100 mg	10 mg	1 mg	0.1 mg	<sup>2</sup> 0.01 mg
Up to 200 g	–	–	–	M1	M1	F2	F1	F2
200 g to 1 kg	–	–	M1	M1	F2	F1/E2	E2	E2
1 to 30 kg	M2	M2	M1	F2	E2	E2	E2	–
30 to 100 kg	M2	M1	F2	F1	E2	–	–	–
More than 100 kg	M2	M1/F2	F1	E2	–	–	–	–

Any calibration process must be done using standard weights. The results obtained must be analyzed to determine if these are within the acceptable tolerances. The standard weights must be selected based on the balance's capacity. The above table complements the previous. It provides guidance in determining the standard weights to use in the calibration of a balance according to its capacity.

## ROUTINE MAINTENANCE

The balance is characterized as an instrument of high precision. For this reason, the operator is only responsible for minimal maintenance limited to the following:

### Daily Activities

1. Clean the weighing plate so that it is kept free of dust. Cleaning is done by using a piece of clean cloth which may be dampened with distilled water. If there is a stain, a mild detergent can be applied. Also a paintbrush with soft bristles can be used to remove particles or dust deposited on the weight plate.
2. Clean the weighing chamber, externally and internally. Verify that the glass is free from dust.
3. Verify that the adjustment mechanisms on the front door of the weighing chamber works adequately.

4. Always use a clean, pre-weighed container for weighing (glass container or weighing paper if possible). Note that plastic can become electromagnetically charged and is not recommended for weighing powdered or granulated chemicals.
5. Any spill must be cleaned immediately to avoid corrosion or contamination. Use 70% ethanol to disinfect the pan of the balance.

**Very important:** Never lubricate a balance unless the manufacturer has expressly indicated it. Any substance interfering with the mechanism of the balance retards its response or definitely alters the measurement process.

**Note:** In general, the manufacturer or the specialized installation representative carries out the maintenance of the balances, according to procedures which vary depending on the type and model.

<sup>1</sup> Guidelines for calibration in laboratories, Drinking Water Inspectorate by LGC (Teddington) Ltd., December 2000.



## TROUBLESHOOTING TABLE

## Electronic balance

PROBLEM	PROBABLE CAUSE	SOLUTION
The balance does not turn on. T	The interconnection cable is disconnected or maladjusted on the balance.	Check the connection. Adjust the cable connector if this is the case.
	Electrical outlet has no power.	Check electrical feed.
The weight reading is incorrect.	The balance was not adjusted to zero before the reading.	Place the balance on zero; repeat the measurement.
	The balance is incorrectly calibrated. C	Calibrate according to the procedure recommended by the manufacturer.
	The balance is not levelled.	Level the balance.
The balance does not show the desired units of measurement on the screen.	The units are incorrectly selected.	Check the procedure defined by the manufacturer to select the required measurement unit.
	The unit required not available or not activated.	Activate the measurement unit according to the procedure defined by the manufacturer.
The balance menu configuration cannot be changed.	The menu may be locked.	Check to see if the locking switch is activated. If this is the case, deactivate it.
The balance is incapable of keeping the selections or changes.	The End key has not been pressed to finish the process.	Verify that the changes and selections are done according to the manufacturer's instructions. Repeat the selection or change.
		Turn the balance off, wait a moment and switch on again.
The balance's reader is unstable.	There is vibration on the surface of the table/counter.	Place the balance on a stable surface.
	The front door of the balance is open.	Close the front door to measure.
The RS232 interface does not function.	The interconnection cable is maladjusted.	Check the connection of the interconnection cable.
The screen shows incomplete readings or is locked.	The microprocessor is locked.	Turn off the balance and a moment later put it on. If the situation persists, seek technical assistance from the service representative.
The screen displays an error code.	Various.	Verify the error codes in the balance's manual.

FUNCTIONAL ERROR	PROBABLE CAUSE
Readings not reproducible (hysteresis).	The measurement cell is dirty.
	The measurement cell is badly assembled.
Non-linear readings.	Defective electronic system.
	Mechanical system is in bad condition.
Digital reading continually goes up or down.	Defective electronic system.
	Change in room temperature.
The digital reading goes up and down continually.	Dirty measuring cell.
	Defective electronic system.
	Environmental problems like air currents, static electricity or vibrations.
The digital screen is blank or shows marks that make no sense.	Defective electronic system.
The screen indicates an overload or negative condition without a load being applied.	Measuring cell damaged by overload.
	Measuring cell is inadequately assembled.
The balance cannot be calibrated.	Defective calibration battery.
	Electronic system is defective.
	Measurement cell is inadequately assembled.

## BASIC DEFINITIONS

**ASTM.** American Society of Testing and Materials.

**Calibration.** Determination of the correct value of an instrument's reading by measurement or comparison against a standard or norm. A balance is calibrated by using standard weights.

**Certified masses.** Masses conforming to the tolerance defined by the certification bodies. The ASTM classes 1 to 4 standards are those most widely used and must be used (a compulsory reference) for performing the calibration routines.

**Exactitude.** The sum of all the balance's errors. This is called *total error band*.

**Hysteresis.** The difference in the results when the load in the balance is increased or decreased.

**Lateral load.** A balance's ability to consistently read the value of masses, no matter where they are placed on the weighing scale. This is also called corner load.

**Lateral load error.** A deviation in the results when an object is weighed placing it in different parts of the weighing plate, i.e. in the centre of the plate and on one of its sides.

**Linear error.** A difference showed when the balance is loaded in a successive manner, increasing the quantity of weight in equal magnitude until it reaches its maximum capacity and unloaded in an analogous process. The differences shown between the readings obtained and the arithmetic values corresponding to the weights used are interpreted as non-linearity.

**Linearity.** Refers to the ability of a balance to perform accurate readings of weights throughout its weighing capacity. A graph showing weight compared to the weight indication on a perfectly linear balance should generate a straight line. In order to determine the linear error of a balance, certified masses must be used. The procedure allows the linear differences to be calculated by reading certified masses with and without preloading. The difference between the readings allows the linear error to be calculated.

**Mass.** A physical property of the bodies related to the quantity of matter, expressed in kilograms (kg), these contain. In physics, there are two quantities to which the name mass is given: **gravitational mass** which is a measure of the way a body interacts with the gravitational field (if the body's mass is small, the body experiences a weaker force than if its mass were greater) and the **inertial mass**, which is a quantitative or numerical measure of a body's inertia, that is, of its resistance to acceleration. The unit for expressing mass is the kilogram [kg].

**OIML.** International Office of Legal Metrology.

**Sensitivity.** The smallest mass detected by the balance or the smallest mass that the balance can measure correctly.

**Sensitivity error.** Constant deviation throughout the weighing range or capacity of a balance.

**Traceability.** The ability to relate the measurements of an instrument to a defined standard.



# Chapter 5



## Water Bath

<b>GMDN Code</b>	36754	16772
<b>ECRI Code</b>	15-108	16-772
<b>Denomination</b>	Water bath	Water bath, shaker

The water bath is an instrument used in the laboratory for carrying out serological, agglutination, inactivation, bio-medical, and pharmaceutical tests and even for industrial incubation procedures. In general they use water, but some baths use oil. The temperature range at which water baths are normally used range between room temperature and 60 °C. Temperatures of 100 °C can be selected, using a cover with special characteristics. Water baths are manufactured with chambers of a capacity ranging from 2 to 30 litres.

- **Immersion type.** These resistors are installed inside a sealed tube and located on the lower part of the container in direct contact with heating medium.
- **External.** These resistors are located on the lower part but on the outside of the tank. These are protected by an isolating material which prevents heat loss. This type of resistor transfers the heat to the bottom of the tank through thermal conduction.

### DIAGRAM OF A WATER BATH

Below is a basic diagram of a water bath. In the diagram, it is possible to observe the electronic control, the screen, the cover (an optional accessory) and the tank. Other components can be installed, e.g. a thermometer and an agitation unit to keep the temperature constant (not shown).

Figure 16. Water bath

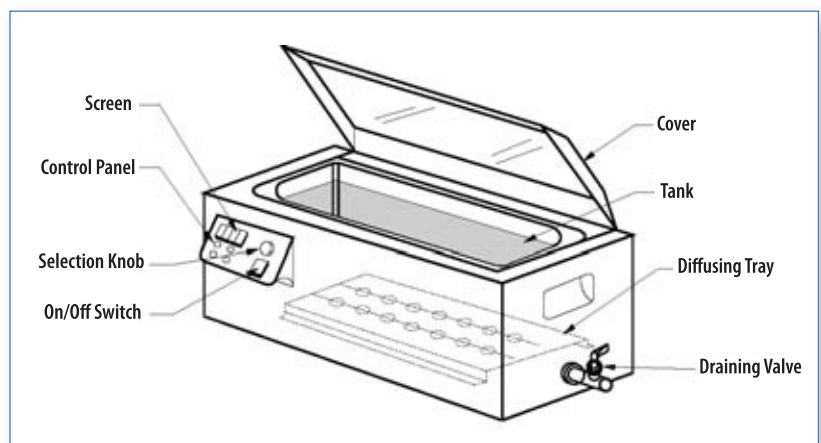

### OPERATION PRINCIPLES

Water baths are made of steel and are generally covered with electrostatic paint with high adherence and resistance to environmental laboratory conditions. Water baths have an external panel on which the controls can be found. They also have a tank made of rustproof material with a collection of electrical resistors mounted on their lower part. By means of these, heat is transferred to the medium (water or oil) until reaching the temperature selected with a control device (thermostat or similar). The resistors may be of the following types:

Figure 17. Immersion and external resistors

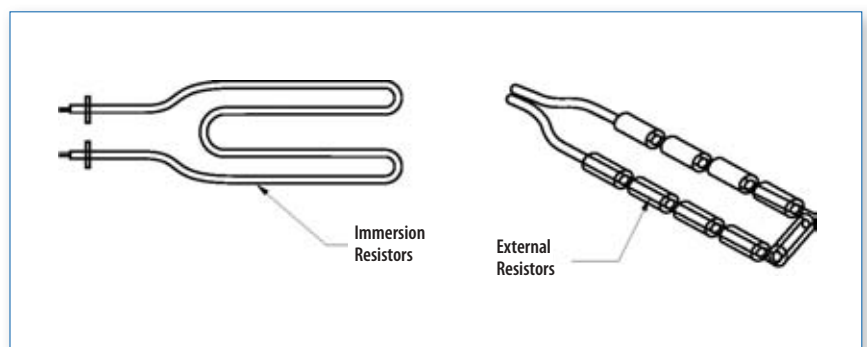

Certain types of water bath have a series of accessories such as agitation systems or circulators, generating carefully controlled movement of the heating medium to keep the temperature uniform. A table which describes the main types of water baths is shown below.

Class	Temperature range
Low temperature	Room temperature up to 60 °C
	Room temperature up to 100 °C
High temperature	Room temperature up to 275 °C. When it needs to reach temperatures above 100 °C, it is necessary to use fluids other than water as the boiling point of water is 100 °C under normal conditions
	This type of bath generally uses oils which have much higher boiling points.
Insulated	Room temperature up to 100 °C with accessories and/or agitation systems (with water).

### WATER BATH CONTROLS

Water baths generally have very simple controls. Some manufacturers have incorporated controls with microprocessors. They vary depending on the type of bath. The diagram of a basic water bath's control panel is shown next.

Figure 18. Water bath controls

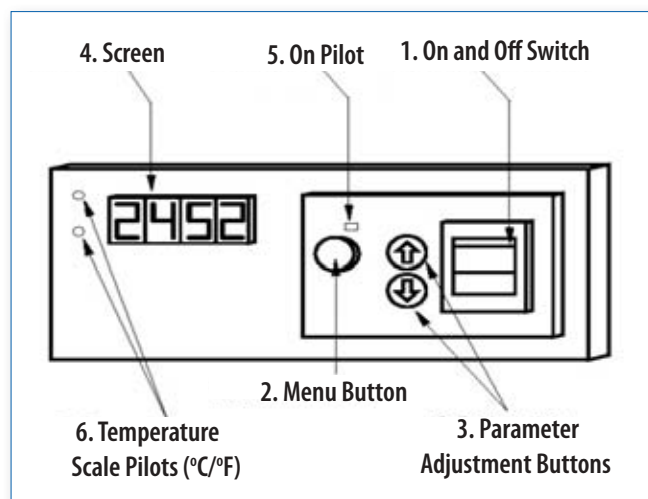

The control panel has these elements:

1. The on and off control switch
2. A Menu button for selecting the operation's parameters: operation temperature, alarm temperature, temperature scale (°C, °F)
3. Two buttons for parameter adjustment
4. A screen
5. A pilot light
6. Pilots (2) for identifying the temperature scale (°C, °F).

### WATER BATH OPERATION

#### Installation

1. Install the water bath close to an electrical outlet. The outlet must have its respective ground pole in order to guarantee the protection and safety of the operator and the equipment. Water baths generally operate at 120 V/60 Hz or 230 V/60Hz. Its installation and use is facilitated by a sink close by for supplying and draining of water.
2. Verify that the location selected is levelled and has the necessary resistance to safely support the weight of the water bath when it is full of liquid.
3. Ensure that the location has a suitable amount of space for putting the samples and the accessories required for the normal operation of the water bath.
4. Avoid placing the water bath where there are strong air currents which can interfere with its normal operation. For example: in front of an air-conditioning unit or window.

#### Safety

1. Avoid the use of the water bath in environments where there are flammable and combustible materials. The equipment has components (resistors generating very high temperatures) which could start an accidental fire or explosion.
2. Always connect the equipment to an electrical outlet with a ground pole to protect the user and the equipment from electrical discharges. The electrical connection must comply with the required norms of the country and the laboratory.
3. Use the water bath exclusively with non-corrosive or non-flammable liquids.
4. Use personal protective elements when working with the water bath. The bath has resistors which can cause burns if inadvertently touched, even a considerable time after turning off the equipment.
5. When working with substances that generate vapours, place the water bath under a chemical hood or in a well ventilated area.
6. Remember that liquids incubated in the water bath tank can produce burns if hands are inadvertently placed inside it.
7. Take into account that the water bath is designed for use with a liquid inside the tank. If the inside is dry, the temperature of the tank can become very high. Use the diffusing tray for placing the container inside of the filled tank of the water bath. This has been designed for distributing the temperature in a uniform way.
8. Avoid using the water bath if any of its controls is not working, e.g. the temperature or limit controls.

## Using the water bath

Before using the water bath, verify that it is clean and that accessories needed are installed. The steps normally followed are:

1. Fill the water bath with fluid to keep the temperature constant (water or oil). Verify that once the containers to be heated are placed, the fluid level is between 4 and 5 cm from the top of the tank.
2. Install the control instruments needed, such as thermometers and circulators. Use additional mounts provided for this purpose. Verify the position of the thermometer's bulb or thermal probe to ensure that the readings are correct.
3. If water is used as the warming fluid, verify that it is clean. Some manufacturers recommend adding products which prevent the formation of fungus or algae.
4. Put the main switch N° 1 in the ON position (the numbers identifying the controls herein correspond to those shown in the diagram). Some manufacturers have incorporated controls with microprocessors which initiate auto-verification routines once the ON switch is activated.
5. Select the operation temperature using the Menu N° 2 button and the buttons for adjusting the parameters.
6. Select the cut-off temperature (in water baths with this control). This is a safety control which cuts off the supply of electricity if it exceeds the selected temperature. This is selected also by using the menu button and is controlled by the parameter adjustment buttons.
7. Avoid using the water bath with the substances indicated below:
  - a) Bleach.
  - b) Liquids with high chlorine content.
  - c) Weak saline solutions such as sodium chloride, calcium chloride or chromium compounds.
  - d) Strong concentrations of any acid.
  - e) Strong concentrations of any salt.
  - f) Weak concentrations of hydrochloric, hydrobromic, hydroiodic, sulphuric or chromic acids.
  - g) Deionised water, as it causes corrosion and perforation in the stainless steel.

## Maintenance

**Warning:** Before carrying out any maintenance activity, disconnect the equipment from the electrical feed outlet.

Water baths are equipment whose maintenance is simple. The recommended routines mainly focus on the cleaning of external components. The most common routines are featured next.

## Cleaning

### Frequency: Monthly

1. Turn off and disconnect the equipment. Wait until it cools to avoid the risk of burns and accidents.
2. Remove the fluid used for heating. If it is water, it can be poured through a siphon. If it is oil; collect into a container with an adequate capacity.
3. Remove the thermal diffusion grid located at the bottom of the tank.
4. Disassemble the circulator and clean to remove scale and potential algae present.
5. Clean the interior of the tank with a mild detergent. If there is any indication of corrosion, use substances for cleaning stainless steel. Rub lightly with synthetic sponges or equivalent. Avoid using steel wool to remove rust stains as these leave particles of steel which could accelerate corrosion.
6. Avoid bending or striking the temperature control capillary tube generally located at the bottom of the tank.
7. Clean the exterior and interior of the water bath with clean water.

## Lubrication

### Frequency: Daily

For water baths with an agitation unit or circulator system:

Lubricate the axis of the circulator's electric motor. Put a drop of mineral oil on the axis so that a good lubricating condition is maintained between the motor's bearings and its axis.

## Periodic inspection

### Frequency: Quarterly

Check the thermometer or temperature controls every three months using known standards. If no reference standard is available, use an ice/water mixture and/or boiling water. Note that the thermometer or the water bath temperature controls should also be checked when the equipment is first installed after purchase.

TROUBLESHOOTING TABLE		
PROBLEM	PROBABLE CAUSE	SOLUTION
There is no power to the instrument.	The water bath is disconnected.	Connect the water bath.
	The switch is defective.	Change the switch.
	The fuse is defective.	Substitute the fuse.
The water bath is not getting hot.	The temperature control not set.	Set the temperature control.
	The resistor(s) is/are defective.	Change resistor(s).
	The limit control is not set	Set the limit control.
The temperature is higher than that selected.	The temperature control is defective.	Change the temperature control if required.
	Verify the selection of the parameters.	
The samples are warmed slowly.	The tank is empty or contains very little fluid.	Fill the tank up to the recommended level.
The temperature is increasing very slowly.	The resistor(s) is/are defective.	Change the resistor(s).
	The temperature control is defective.	Substitute temperature control.

## BASIC DEFINITIONS

**Circulator.** An apparatus that shakes or stirs fluids to keep their properties (temperature, color, density) homogenous. These are also called agitators.

**Diffusing tray.** Device located at the bottom of the water bath to support the containers located inside the tank. It also allows thermal convection currents generated in the fluid contained in the tank to circulate from top to bottom and back to the top, maintaining the temperature homogeneous at the level selected by the operator. In general the diffusing tray is made of stainless steel.

**Electrostatic painting.** A painting process that uses the particle-attracting property of electrostatic charges. A potential difference of 80-150kV is applied to a grid of wires through which the paint is sprayed to charge each particle. The metal objects to be sprayed are connected to the opposite terminal of the high-voltage circuit, so that they attract the particles of paint. The piece covered with paint particles is then placed in an electrical oven to melt the particles, making them adhere strongly to the piece.

**Fuse.** A safety device which protects the electrical circuits from excessive current. Fuses are made of materials whose dimensions and properties equip them to work well within some predefined conditions. If for some reason the design parameters are exceeded, the material burns out and interrupts the passage of the electrical current.

**Immersion resistor.** An electrical resistor (see definition below) inside of a sealed tube. These are generally used for heating fluids as water or oil.

**Resistance.** Opposition that a material or electrical circuit imposes to the flow of electric current. It is the property of a circuit that transforms electrical energy into heat as it opposes the flow of current. The resistance [R], of a body of uniform section such as a wire, is directly proportional to the length [l] and inversely proportional to the sectional area [a]. The resistance is calculated by the following equation:

$$R = k \times \frac{l}{a}$$

Where:

k = constant that depends on the units employed

l = Length of the conductor

a = sectional area of the conductor

The ohm ( $\Omega$ ) is the common unit of electrical resistance; one ohm is equal to one volt per ampere.

# Chapter 6



## Biological Safety Cabinet

<b>GMDN Code</b>	15698	20652	20653	20654
<b>ECRI Code</b>	15-698	20-652	20-653	20-654
<b>Denomination</b>	Cabinets, biological safety	Cabinets, biological safety, class I	Cabinets, biological safety, class II	Cabinets, biological safety, class III

This equipment is designed for controlling aerosols and microparticles associated with managing potentially toxic or infectious biological material in laboratories in activities such as agitation, centrifugation, pipetting, and opening of pressurized containers. Safety cabinets have been designed to protect the user, the environment and the sample manipulated using appropriate ventilation conditions. They are also known as *laminar flow cabinets* and/or *biosafety cabinets*.

### ILLUSTRATION OF A BIOLOGICAL SAFETY CABINET

Figure 19. Biological safety cabinet



### PURPOSES OF THE EQUIPMENT

The biological safety cabinet is used for the following:

1. To protect the worker from risks associated with the management of potentially infectious biological material.
2. To protect the sample being analyzed from becoming contaminated.
3. To protect the environment.

The cabinets are used for routine work related to pathogens (parasites, bacteria, virus, fungus), cell culture and under very precise conditions, the management of toxic agents.

### OPERATION PRINCIPLES

The biological safety cabinet is a chamber generally constructed of steel. It has a front glass window of adjustable height, a ventilation system with an electrical motor, a ventilator and a set of ducts which while functioning, generate a negative pressure condition inside the cabinet. This forces the air to flow from inside the cabinet through the front opening to generate a curtain of air protecting the operator. Internally, the air is conducted through a series of grids and ducts to be finally treated in HEPA<sup>1</sup> filters. Depending on the design of the cabinet, the air is recycled inside the laboratory or extracted and renewed in diverse proportions. The air flow, which in Class II cabinets moves from the filter towards the work surface, is laminar. A summary of the existing type of cabinets and their principal characteristics is presented next.

<sup>1</sup> HEPA: High Efficiency Particulate Air.



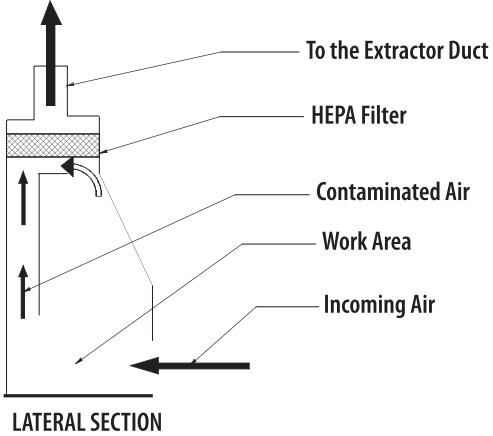
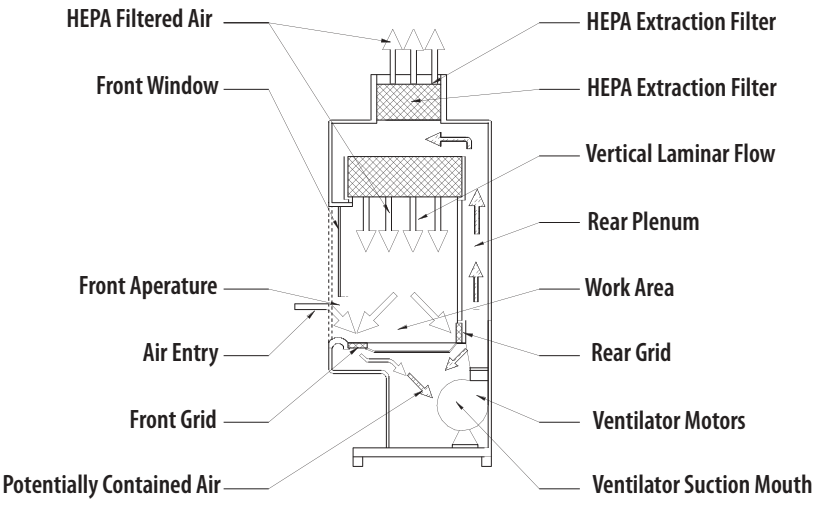

Summary of biological safety cabinet types

Type of cabinet, with illustration	Characteristics
<b>CLASS I — TYPE A</b>	
	<ol style="list-style-type: none"> <li>1. Protection provided: to the operator and the environment.</li> <li>2. Air velocity on entering the cabinet: 38 cm/s.</li> <li>3. Suitable for working with bio-safety level<sup>1</sup> 1, 2 or 3 agents.</li> <li>4. Filtration HEPA, located in extraction system which may or may not be connected to the exterior.</li> <li>5. Disadvantage: Does not protect the sample manipulated in the cabinet.</li> </ol>
<b>CLASS II — TYPE A</b>	
	<ol style="list-style-type: none"> <li>1. Protection offered: To the operator, the product and environment.</li> <li>2. Air velocity on entering the cabinet: 38 cm/s.</li> <li>3. Suitable for working with agents with biosafety level 1, 2 or 3.</li> <li>4. Filtration system: two HEPA filters, one located on the work surface; the second on the extraction system which may or may not be connected to the exterior. If they are connected to the exterior, it utilizes a bell type connection.</li> <li>5. They recycle approximately 70 % of the air volume and renew 30 % of it.</li> </ol>

<sup>1</sup> See biosafety classifications levels of agents in the following section "Biological safety".

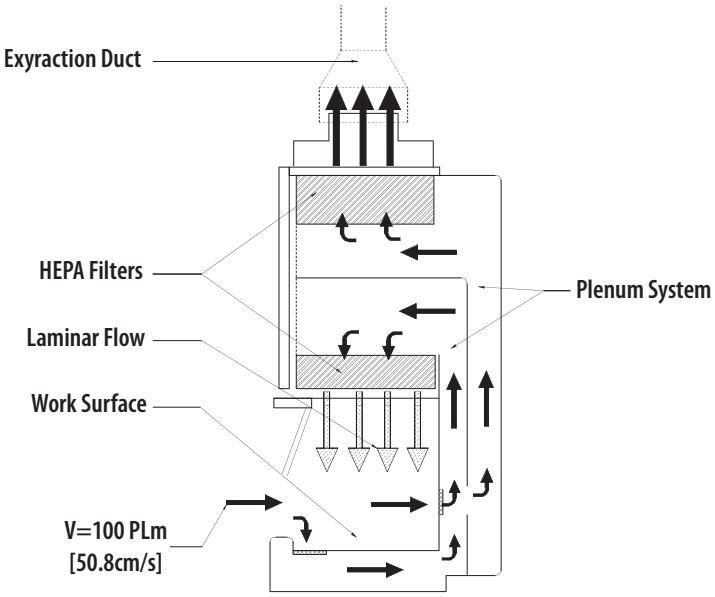
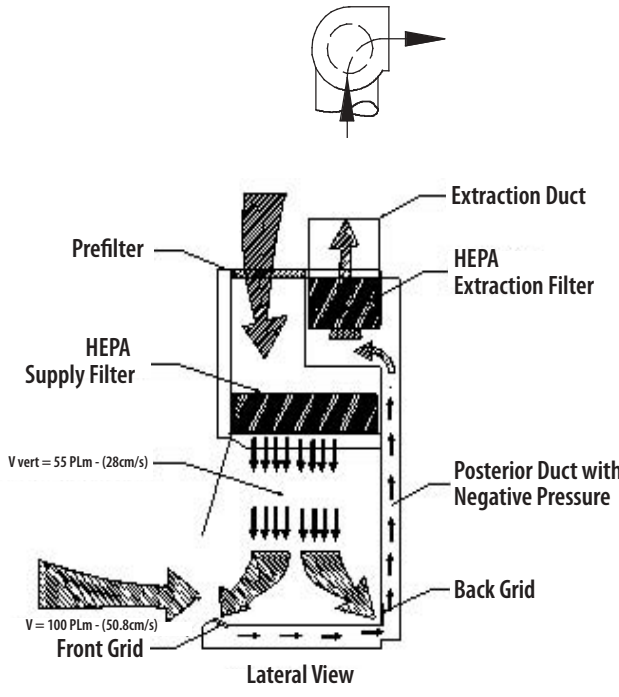

Type of cabinet, with illustration	Characteristics
<b>CLASS II — TYPE B1</b>	
	<ol style="list-style-type: none"> <li>1. Protection provided: to the operator, the product and the environment.</li> <li>2. Air velocity entering the cabinet: 50.8 cm/s.</li> <li>3. Suitable for working with agents with biosafety level 1, 2 or 3.</li> <li>4. Filtration system: Two HEPA filters. It extracts potentially contaminated air (70 %) through a duct and recycles inside of the cabinet, after filtering, air taken from the exterior, through the front grid (30 %).</li> <li>5. All biologically contaminated ducts have a negative pressure.</li> <li>6. Allows work with small quantities of toxic and radioactive chemicals.</li> </ol>
<b>CLASS II — TYPE B2</b>	
	<ol style="list-style-type: none"> <li>1. Protection provided: to the operator, the product and the environment.</li> <li>2. Air velocity on entering the cabinet 50.8 cm/s.</li> <li>3. Suitable for working with agents of biosafety level 1, 2 or 3.</li> <li>4. Filtration system: Two HEPA filters. It is known as the total extraction cabinet. It does not have any type of recirculation.</li> <li>5. All biologically contaminated ducts have a negative pressure.</li> <li>6. It has an extraction duct which allows work with toxic and radioactive chemicals.</li> </ol>

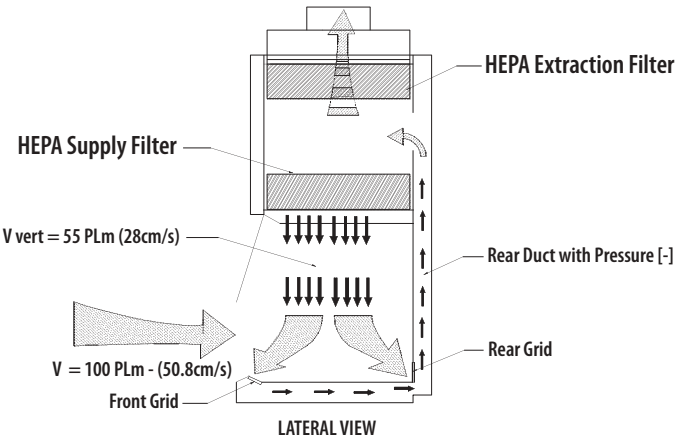
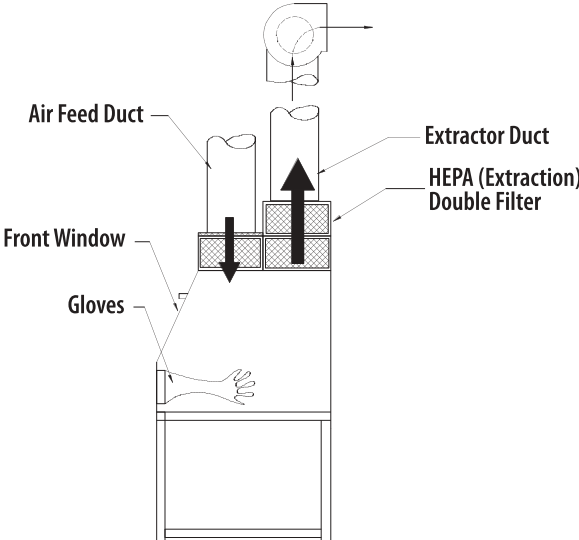
Type of cabinet, with illustration	Characteristics
<b>CLASS II — TYPE B3 OR A/B3</b>	
 <p style="text-align: center;">LATERAL VIEW</p>	<ol style="list-style-type: none"> <li>1. Protection provided: to the operator, the product and the environment.</li> <li>2. Air velocity on entering the cabinet: 50.8 cm/s.</li> <li>3. Suitable for working with agents of biosafety level 1, 2 or 3.</li> <li>4. Filtration system: Two HEPA filters.</li> <li>5. All biologically contaminated ducts have a negative pressure.</li> <li>6. It is known as a combined cabin. It can be connected by means of a duct. It is denominated as Type B3. If the duct is missing, it is a Type A. It recycles 70 % of the air volume inside the cabinet.</li> </ol>
<b>CLASS III</b>	
 <p style="text-align: center;">LATERAL VIEW</p>	<ol style="list-style-type: none"> <li>1. Protection provided: to the operator, the product and the environment.</li> <li>2. Filtration system: two HEPA filters in series in the extraction; a HEPA filter in the admission.</li> <li>3. Suitable for working with agents classified biosafety level 4.</li> <li>4. Totally sealed cabinet. The intake and extraction elements are conducted through a double-door pass-through box. The manipulation of materials is done by using sealed gloves at the front of the cabinet.</li> </ol>

## BIOLOGICAL SAFETY<sup>1</sup>

Microorganisms have been classified into four categories based on factors such as pathogenicity, infectious doses, transmission modes, and host range, availability of preventive measures and effectiveness of treatment for the disease caused.

1. **Risk level 1 group** is composed of biological agents very unlikely to cause sickness in healthy humans or animals. (No individual and community risk).
2. **Risk level 2 group** is composed of pathogens which cause sickness in humans or animals but unlikely to be dangerous to laboratory workers, the community, domestic animals or the environment under normal circumstances. Those exposed in the laboratory rarely become seriously ill. There are preventive measures and effective treatment available and the risk of dissemination is limited. (Moderate individual risk, limited community risk).
3. **Risk level 3 group** is composed of pathogens which usually cause serious sicknesses to human beings and animals and produce a serious economic impact.  
However, infection by casual contact by one individual to another is not common. The sicknesses these produce are treatable by antimicrobial or anti-parasitic agents. (High individual risk, low community risk).
4. **Risk level 4 group** is composed of pathogens which usually produce very serious sicknesses in human beings or animals, frequently without treatments available. These agents are easily spread from one individual to another or from animal to human being or vice versa, directly or indirectly or by casual contact. (High individual risk, high community risk).

## INSTALLATION REQUIREMENTS

The following are requirements for a cabinet to function adequately:

1. A laboratory area protected from air currents from windows or air-conditioning systems. The cabinet must also be located far from the laboratory circulation zones in order to avoid air currents that could affect the curtain of air inside the cabinet. It must also be verified that the cabinet is not installed alongside other types of cabinets such as chemical hoods.
2. An electrical connection equipped with the respective control and safety elements; the electrical outlet with a ground pole.
3. A levelled and firm table designed for supporting the weight of the cabinet and allowing the operator to work comfortably. There must be free space for placing the feet and its height must be adequate.
4. The floor on which it is located must be flat and levelled.
5. The free space around the cabinet recommended by the manufacturer must be respected. Likewise, the height of the room must be verified (the ceiling must be of recommended height so that it can function without hindrance).
6. Type B cabinets must have an extraction duct equipped with the following required control devices: regulating valves that allow the flow of air to be isolated and regulated.
7. Gas connections must be in the immediate vicinity of the cabinet in order to facilitate the connection to these service valves.
8. The cabinet must be certified annually to verify that it complies with the established requirements in the NSF 49 Regulation.

## USE OF THE SAFETY CABINET

Correct utilization of the biological safety cabinet is achieved by complying with the following instructions:

1. Plan the work to be done in the biological safety cabinet in advance. Determine what procedure and equipment will be used. Coordinate the time of the cabinet's use with the other laboratory professionals in order to avoid interruption or undesired traffic while it is in use.
2. Turn on the cabinet. Turn off the UV lamp if lit. Turn on the fluorescent light lamp and the cabinet's ventilator. Verify that the grids in front and behind are free of obstructions. Prepare the work area. Allow the cabinet to function for at least 15 minutes.
3. Wash hands and forearms with germicidal soap. Put on the personal protective apparel: coat/overall with long sleeves and adjustable cuffs, protective eyeglasses and mask if the work requires it. Prepare the interior surfaces of the cabinet applying 70% ethanol or a suitable disinfectant. After this, let the air flow through.
4. Only load and install the materials and equipment required for the test or manipulation. Distinguish between the clean areas and dirty areas. Place the material in such a way that the clean materials do not mix or cross used or dirty materials or impede the circulation of the internal air through the front and back grids. Place a biosafety bag for disposing waste materials, a container with disinfectant for the pipettes and a container for storing sharps. Avoid locating very large objects near one another. Upon finalizing the placing of the materials, the flow of air must be allowed to sweep through the cabinet for approximately 3 to 5 minutes in order to eliminate any particle produced or freed during the loading of materials and equipment.
5. Initiate activities. Slowly introduce hands into the work area. Carry on the processes and tasks in a methodical and careful manner (from the clean areas to the

<sup>1</sup> *The Laboratory Biosafety Guidelines*, 3rd. Edition-Draft, Health Canada, 2001.

potentially contaminated areas). Keep the materials at least 10 cm behind the front grid. Try to perform the most risky and contaminating activities towards the back of the cabinet's work area. Avoid the use of open flames of lighters since this breaks the laminar flow pattern and may burn the filter. Avoid removing hands from the work area until all procedures are accomplished and the potentially dangerous materials are disposed of in the biosafety bag or in the pipette and sharp containers.

6. Clean the cabinet, allowing the air to flow freely for 3 to 5 minutes upon ending all the procedures.
7. Decontaminate the surfaces of all the materials and equipment in contact with the biologically contaminated material. Apply 70% ethanol or a suitable disinfectant and allow drying. Lift the equipment and materials and disinfect the area underneath. Cover the open containers before removal from the work area. Transfer materials to their appropriate place (incubator, autoclave, etc.).
8. Discard the gloves and remove personal protective elements. Dispose of these following the laboratory's established procedure. Wash hands with a lot of water and soap.
9. Turn off the ventilator, the fluorescent lamp, close the front opening and turn on the ultraviolet light.

**Note:** In case of a leak or spill inside the cabinet while in use, it must be kept in operation and all the objects or equipment involved must undergo a process of surface decontamination. This will prevent the cabinet from releasing contaminants.

### Decontamination of the cabinet

The decontamination of the biological safety cabinet is an activity which must be done before any maintenance work involving opening its surfaces or internal components. Whenever any of the processes indicated next are needed, decontamination of the cabinet must be done previously.

1. Changing of filters.
2. Conducting tests requiring access to the interior surfaces or exposure of the cabinet.
3. Before conducting certification tests when the cabinet has been used with classified agents such as level 2 or 3 biological risk agents.
4. Before moving the cabinet to a different location.
5. After a spill of a material containing high risk agents.

The most suitable decontamination procedure must be defined by the professional responsible for industrial safety and professional risks. In annex G of the NSF 49 Standard, the procedure for decontaminating the cabinet using depolymerised paraformaldehyde is described. Only professionals who have received the relevant training must conduct such procedures.

## ROUTINE MAINTENANCE

**Warning:** The maintenance of internal components must only be done by trained and qualified personnel. In order to carry out maintenance on the internal components, decontamination must be done previously. Personal protection must be worn to perform the routines.

General maintenance required for the biological safety cabinet is for the most part simple to perform. The routines and frequencies are shown below:

### Frequency: Weekly

1. Decontaminate the work surface and the interior surfaces of the cabinet with 70% ethanol.
2. Clean the front glass door and the surface of the ultraviolet lamp, using a domestic cleaning solution.
3. Verify the precision of the manometer's reading, indicating any fall in pressure flowing through the HEPA filter. Register the date and the reading in the cabinet's log book.

### Frequency: Monthly

1. Clean the exterior surfaces, especially the front and the upper part using a piece of damp cloth in order to remove the dust.
2. Disinfect the surface of the lower compartment with 70% Ethanol or a suitable disinfecting solution.
3. Verify the state of the service valves.
4. Do the tasks due on a weekly basis.

### Frequency: Annually

1. Carry out the certification process according to established outlines in the NSF 49 regulation.
2. Check the intensity of the UV lamp<sup>1</sup> with a radiometer. Substitute it if necessary.
3. Test the state of the fluorescent lamp. Substitute it if necessary.
4. Perform the tasks due on a monthly basis.

### Removal of the work surface

For the removal of the work surface the following procedure is required:

1. Decontaminate the surface before removing it.
2. Loosen and remove the attachment screws located on the front part of the work surface.
3. Loosen, but do not remove the attachment screws located on the back part.
4. Raise the front end and remove it, pulling it towards the front part of the cabinet.
5. Decontaminate the interior part of the work surface.
6. To assemble it, perform the activities described in steps 2, 3 and 4 in reverse order.

<sup>1</sup> UV lamps have irradiation capacity lasting approximately 7,500 hours. Some manufacturers suggest annual substitution.

### Changing of the ultraviolet lamp

In order to change the ultraviolet lamp, the manufacturers' instructions must be followed. In general, the following procedures are done:

1. Turn on the cabinet and leave it working for 5 minutes.
2. Raise the front window to its maximum position.
3. Decontaminate the interior surfaces and the UV lamp.
4. Disconnect the electrical feed to the cabinet.
5. Disconnect the UV tube from its connectors turning it 90 degrees. Next, install a spare part with the same characteristics as the original. Some manufacturers have installed the lamps on a plate located in the front of the cabinet, which is necessary to unscrew and lift so that the assembly of the lamp is kept visible. Once this is done, the lamp can be substituted as indicated above.

### Specialized maintenance

Eventually, the cabinet will require specialized maintenance. The following are some procedures to be done according to the manufacturer's technical service manuals by a specialized contractor.

1. Annual certification in accordance with Regulation NSF 49 outlines.
2. Motor change. Generally, it uses maintenance-free sealed rollers and function by induction through frequency control. This motor does not have brushes. (\*)<sup>1</sup>.
3. Replacing ventilators. (\*)
4. Replacing the HEPA filter (\*). The replacement frequency depends on the use of the cabinet and the system of environmental control installed in the laboratory. If there is a good control of dust, the filter could last many years.
5. Repair of the electronic control system: flow control alarms, position of the window, velocity controls.
6. Repair/cleaning of the flow regulator valves, bell type adjustment fittings.

### Cabinet certification

The certification process of the biological safety cabinets is regulated by Standard NSF 49, which applies to all Class II cabinets. This defines materials, design criteria and construction, operation parameters and tests which allow the cabinet to be guaranteed as safe and suitable for the work performed. The following is a list of tests, in which standards mentioned are included. The standards must be consulted for details. The certification process comprises the following tests:

1. **Air tightness test.** This is done on the exterior surfaces. Determine if joints, seals, penetration and solderings are free from leaks.
2. **HEPA filter leak tests.** Determines the integrity of the supply and extraction of HEPA filters, their location and mounted frames.

3. **Temperature increase test.** Determines the maximum temperature increase in the cabinet when the ventilator and lights are operating.
4. **Noise test.** Determines the level of noise produced by the cabinet.
5. **Luminous intensity test.** Determines the luminous intensity on the cabinet's work surface.
6. **Vibrations test.** Determine how much vibration there is in the cabinet when it is functioning.
7. **Protection test** to personnel, to the product and cross contamination biological tests. The test determines if aerosols are contained in the cabinet, if external contaminants reach the work table area and if aerosols are reduced by the cabinet.
8. **Stability test.** Determines if the cabinet has structural stability. Analyzes the resistance to shaking, to distortion by means of applied force, to deflection of the work surface subjected to load and resistance to the tilting of the work surface due to heavy loading conditions.
9. **Vertical flow velocity test.** Determines the velocity of the air moved vertically towards the work surface.
10. **Entry flow velocity test.** Determines the velocity at which the flow enters the cabinet through the front opening and the cabinet's extraction volume.
11. **Smoke test.** Determines if the flow of air along the entire perimeter of the front opening advances towards the cabinet, and if the vertical flow moving towards the bottom does not show dead points or flow backs on the work surface.
12. **Drainage escape test.** Defines the contention capacity for spills below the work surface.
13. **Motor/ventilator system functioning test.** Determines if the system provides the necessary static pressure.
14. **Electric system test.** Determines if there are potential risks of electrical discharges. Measures the escaping currents, the polarity, the functioning of the ground defect protection system and the ground circuit resistance.

### FUNCTIONAL EVALUATION (ALTERNATIVE)

In case there are biological safety cabinets in the laboratory, but no authorized certification services available, the personnel responsible for maintenance has the option of conducting annual revision procedures based on Standard NSF 49. Duly documented, it should identify with low levels of uncertainty if the cabinet is in good condition and its operation normal<sup>2</sup>. The following are outlines of how these activities must be done.

1. **Installation evaluation.** Verify that the cabinet installation conditions are in accordance with the recommendations from the manufacturer.

<sup>1</sup> (\*) These require specialized decontamination beforehand.

<sup>2</sup> The functional evaluation is essentially based on the availability (institutional or zonal) of properly trained and experienced technicians and engineers.

2. **Operational evaluation.** Test to see if the cabinet is working in accordance with its manufacturing and design characteristics.
3. **Performance evaluation.** Verify the cabinet's capacity to provide an adequate work space in normal and critical working conditions.

In the following table are featured the parameters to be taken into account in the functional evaluation. These are generally included in inspection forms<sup>1</sup> designed for this purpose.

<sup>1</sup> Each institution designs its own formats for record keeping of technical maintenance.

**Table of functional evaluation of biological safety cabinets**

Parameters	Observation
<b>Institutional identification of cabinets</b>	<b>Brand, model, type, series, location, inventory code, date.</b>
<b>ELECTRICAL</b>	
Voltage	Voltage measurement. Requires a voltmeter.
Amperage	Amperage measurement. Requires a voltmeter or amperemeter clip.
Motor/ventilator	Verification of operation temperature. Verify noise level and vibration.
Illumination – Fluorescent	Confirmation that the lamp is functional.
– Ultraviolet	Confirmation of the operational hours of the lamps and their light intensity. Requires a radiometer.
Electrical outlet	Integrity revision, quality of the contact and available voltages.
Switches	Control of state and integrity.
Integrity cables and connectors	Visual verification.
Alarms	Testing of state and calibration.
<b>PHYSICAL</b>	
Internal/external finishes	Visual verification.
State of filters and pre-filters	Visual verification. There must be no leaks, neither in the filtering material nor in the seals.
Seals/gaskets	Visual verification. There must be no leaks.
Sliding window	Visual verification. Must be able to be moved smoothly and maintain the selected positions.
<b>OPERATIONAL</b>	
Flow velocity	Control of velocity according to the class and type of cabinet. Requires an anemometer (wind gauge).
Noise level	Requires audiometer.
Pressure differential in the HEPA filter.	Take a manometer reading of the cabinet.
<b>PERFORMANCE</b>	
Counting of particles	Method defined in the Federal Standard 209D, E. Requires DOP generator, photometer and particle counter.
<b>CONDITIONS OF THE INSTALLATION AREA</b>	
Temperature	Requires thermometer: approximately 20–22 °C.
Humidity	Requires hygrometer: approximately 45–55 %.
Cleanliness	Must be adequate.
Air currents	There must be no air currents to affect the working of the cabinet.

TROUBLESHOOTING TABLE <sup>1</sup>		
PROBLEM	PROBABLE CAUSE	SOLUTION
Neither the light nor the ventilation system in the cabinet works.	The cabinet is disconnected from the electrical outlet.	Verify that the cabinet is connected to an electrical outlet and that the cable is well connected to the cabinet's electrical box.
	There is no electrical feed in the connection.	Confirm that the electrical outlet is energized and that the circuit breaker is not deactivated (thermo magnetic protection). Restart switches.
The cabinet's ventilator is functioning but the light does not.	The lamp is defective.	Replace the lamp. Use one with the same characteristics of the original
	The lamp is badly connected.	Check the lamps connection. Adjust to the correct position.
	The thermo magnetic protection of the service breaker is activated.	Reconnect the circuit breaker.
	The lamp's wire is disconnected.	Check the lamp's wire.
	The lamp's ballast is defective.	Replace the ballast.
The ventilator is not blowing but the light is coming on.	The front window is closed.	Open the window until it reaches the work position.
	The ventilator's motor is defective.	Replace the motor ventilator set.
	The ventilator's motor is disconnected.	Check the motor's connections.
The manometer indicates an increase in the fall of pressure through the filter.	Retention of particles in the HEPA filter has increased.	Normal process during the useful life of the filter.
	There is blockage in the grids or return slots.	Verify that the grids are not obstructed by equipment or material.
	The extraction pipe is obstructed.	Test that there are no existing blockages or restrictions in the extraction pipe.
	There is a blockage or restriction under the work surface.	Verify that the pipe below the work surface is free of obstructions.
There is contamination in the samples manipulated in the cabinet.	Work procedures are inadequate.	Check that the cabinet is being used according to procedures and good practices.
	Restrictions in the return slots or blockage of the extraction duct.	Test the return and extraction system to see if they are free from obstructions.
	The cabinet's external factors affect its flow patterns on the inside and cause contamination.	Verify the installation of the cabinet and the procedures that are being carried out.
	The HEPA filter is defective.	Replace the HEPA filter and certify the cabinet.

<sup>1</sup> Purifier® Delta® Series, *Biological Safety Cabinets, User's Manual*, Kansas City, Labconco Corporation, Part N° 36960-20, Rev. A ECO B296.





## BASIC DEFINITIONS

**Aerosol.** A suspension of fine solid or liquid particles in the air. Their average diameter ranges between  $10^{-4}$  and  $10^{-7}$  cm.

**Air supply.** Air which enters the cabinet through the front or work opening and replaces the air extracted from the cabinet.

**Biological Safety cabinet.** Equipment with appropriate ventilation conditions protecting the user, the environment and the sample from aerosols and microparticles, associated with the management of potentially infectious biological material in laboratories as a result of activities such as agitation, centrifugation, use of pipettes and opening of pressurized containers.

**Certification.** Procedure establishing that the biological safety cabinet's functioning complies with criteria and minimum requirements to operate safely. Standard NSF 49 applies to the Class II cabins, Type A, B1, B2 and B3.

**Decontamination.** Removal or destruction of infectious agents; removal or neutralization of toxic agents.

**HEPA filter.** A filter with the ability to remove particles with average diameters of  $0.3 \mu\text{m}$  with 99.97 % efficiency. These filters are constructed of Boron silicate micro fibres bonded together with a water resistant adhesive. The filtering material is folded inside of a frame with the aim of increasing the filtration area.

**Laminar flow.** Non-turbulent flow of a viscous fluid (e.g. air) in layers near a boundary. It occurs when Reynolds number [Re] is less than 3000.

**NSF.** An acronym of the *National Sanitation Foundation*, a non-profit organization dedicated to research, education and service, which seeks to resolve problems related to human beings, promote health and enrichment of the quality of life through conservation and improvement of the environment. NSF standards supply the basic criteria for promoting salubrious conditions and public health protection.

**Toxic.** A substance with a physiologically adverse effect on the biological systems.

**Ultraviolet light (UV).** This is electromagnetic radiation, the wavelength of which is between 200 and 390 nm. It is used in biological safety cabinets for its germicidal properties.

**Work surface.** A surface used when performing work, operation or activity inside the biological safety cabinet in this case.

# Chapter 7



## Centrifuge

<b>GMDN Code</b>	15115	10778	10778
<b>ECRI Code</b>	15-115	15-117	15-116
<b>Denomination</b>	Centrifuges, standing, low velocity, non-refrigerated, for blood bank	Centrifuge, standing, refrigerated	Standing centrifuge

The word *centrifuge* comes from the Latin word *centrum* which means *centre* and *fugere* which means to escape. The centrifuge is designed to use the centrifugal force generated in rotational movements to separate the constitutive elements of a mixture. There is a wide range of centrifuges capable of serving specific industry and research needs. This chapter focuses on standing centrifuges normally used in public health and clinical laboratories.

### PHOTOGRAPH OF CENTRIFUGE



Photo courtesy of Beckman Coulter

### PURPOSE OF THE CENTRIFUGE

The centrifuge uses centrifugal force (the force generated when an object rotates around a single point), for separating solids suspended in a liquid by sedimentation, or liquids of diverse density. The rotational movements allow forces much greater than gravity to be generated in controlled periods of time. In the laboratory, centrifuges are generally used in processes such as the separation of solid components from biological liquids through sedimentation and in particular of blood components: red cells, white cells, platelets among others and for conducting multiple tests and treatments. There are several kinds of centrifuges. The most widely used in public health, surveillance and clinical laboratories are the table-top centrifuge, the ultracentrifuge, the haematocrit centrifuge and the standing centrifuge.

### OPERATION PRINCIPLES

Centrifuges represent a practical application of Newton's law of motion. When a body of mass [m] turns around a central point [O], it is subjected to a *centripetal* force [N] directed towards the rotation axis with a magnitude  $N = m\omega^2R$ , where [m] is the mass of the body, [R] is the radius and  $\omega$  is the angular speed. Centrifuges possess a rotating axis on which is mounted a rotor with sample receiving compartments. Tangential speed is defined by the following equation:  $VT = \omega R$ .

When the system spins at a speed of  $\omega$  radians per second, the samples are subjected to the *centrifugal force*  $F_p$  of the same magnitude as  $N$ , but in an opposite direction. The figure shown below<sup>1</sup> features a diagram of the concept, of its actual application and of the obtained result. This  $F_p$  force acts on particles in the substance centrifuged, causing them to separate as a result of differences in density. Denser particles will settle at the bottom of the tube in shorter periods of time, while lighter ones require longer periods of time, settling onto those of greater density. The relationship between the centrifugal acceleration [ $\omega^2 r$ ] to a given radius [ $r$ ] and the force of gravity [ $g$ ] is known as the *relative centrifugal field* or  $[RCF]^2$ .

$$RCF = \frac{r\omega^2}{g}$$

The RCF is the tool which allows rotors of different specifications to be compared when equivalent centrifugal effects are required.

**COMPONENTS OF THE CENTRIFUGE**

The most important components of a centrifuge are the following<sup>3</sup>:

The electric/electronic control which generally has the following elements:

1. On and off control, operation time control (timer), rotation speed control (in some centrifuges), temperature control (in refrigerated centrifuges), vibration control (safety mechanism) and brake system.

2. Refrigeration system (in refrigerated centrifuges).
3. Vacuum system (in ultracentrifuges, not shown in the figure).
4. Base
5. Lid/cover
6. Casing
7. Electric motor
8. Rotor. There are different types of rotors. The most common are the fixed angle, the swinging buckets, the vertical tube and the almost vertical tube types, which are explained next.

**Sectional diagram of a centrifuge (numbers correspond to descriptions in the text above)**

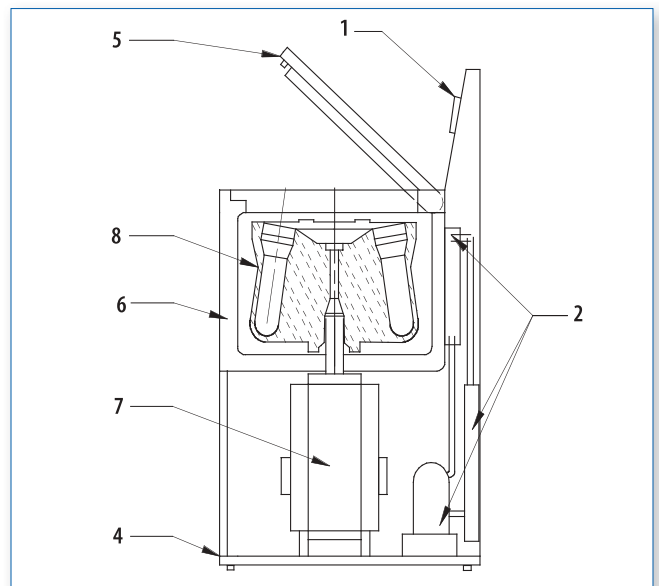

**Figure 20. Centrifugal force concept**

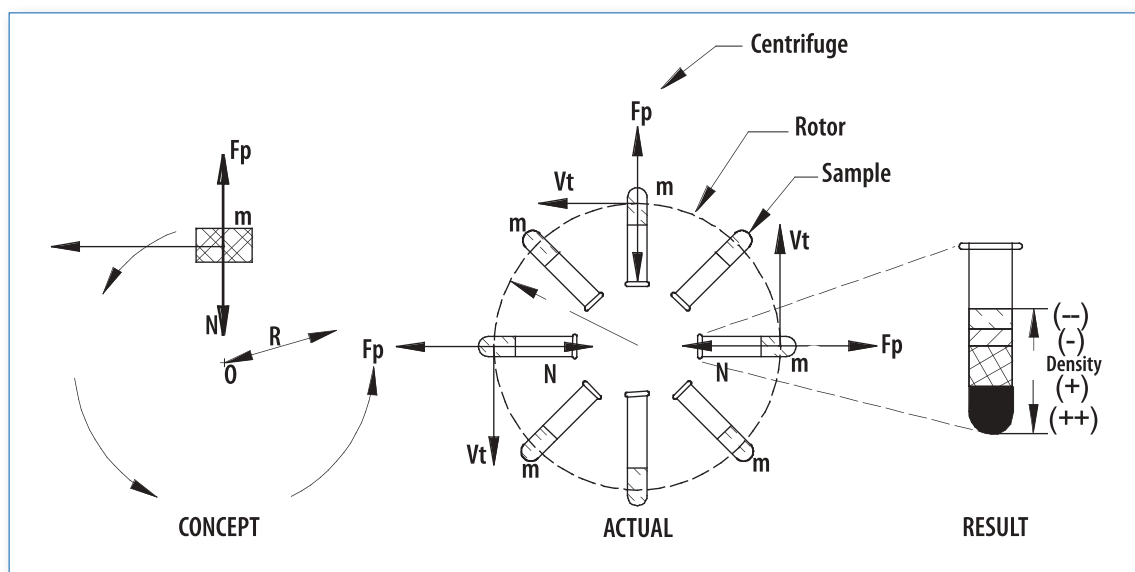

<sup>1</sup> Newton's law of movement, together with the explanation of the inertia marks of reference can be consulted in books on physics, chapters on uniform circular movement.  
<sup>2</sup> RCF. Relative Centrifugal Field.  
<sup>3</sup> The numbers identifying each component correspond to those in the sectional diagram of the centrifuge.

### Types of rotors

Centrifuges use many different types of rotors. Among the most commonly used are the following:

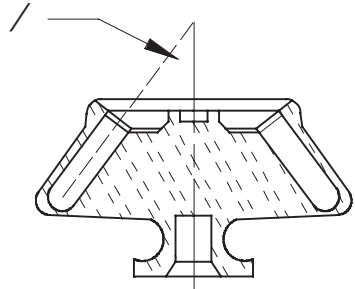
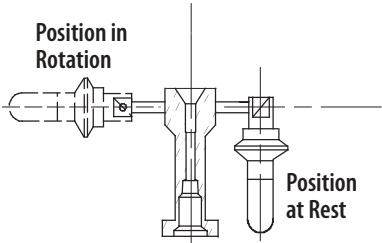
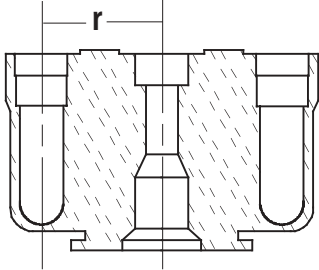
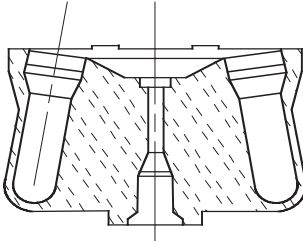
Type of rotor	Characteristics	Transversal cross-section
Fixed angle rotors.	These are general purpose rotors. They keep tubes at a fixed angle $[\alpha]$ which by design, is specified between 20 and 45 degrees. They are used for sediment sub-cellular particles. The angle shortens the trajectory of the particles and the centrifugation time compared to the swinging buckets rotors.	 <p>The diagram shows a cross-section of a rotor with two tubes mounted at a fixed angle to the horizontal axis. A dashed line indicates the angle of the tubes. The rotor has a central hub and a base.</p>
Swinging buckets rotors.	These are used for carrying out isopycnic studies (separation by density) and rate-zonal studies (separation by sedimentation coefficient), where maximum resolution of the zones is required for the sample.	 <p>The diagram illustrates a swinging bucket rotor. On the left, a tube is shown in its 'Position in Rotation', which is swung outwards. On the right, a tube is shown in its 'Position at Rest', which is vertical. The rotor has a central hub and a base.</p>
Vertical tube rotors.	This type of rotor keeps tubes parallel to the rotational axis. Thus, separate bands are formed across the tube's diameter, not its length. These rotors are used for carrying out isopycnic studies and in some cases, zonal limit separations where a short centrifugation time is important. These rotors use specially designed tubes.	 <p>The diagram shows a cross-section of a rotor with two tubes mounted vertically, parallel to the rotational axis. A dimension line labeled 'r' indicates the radius from the central axis to the center of the tubes. The rotor has a central hub and a base.</p>
Almost vertical tube rotors.	This type of rotor is designed for gradient centrifugation when some sample components do not participate in the gradient. The small angle of these rotors reduces the centrifugation time in comparison to fixed angle rotors.	 <p>The diagram shows a cross-section of a rotor with two tubes mounted at a small angle to the horizontal axis. The rotor has a central hub and a base.</p>

Normally, manufacturers specify rotors to be used in centrifuges by providing specialized publications of tables with the following information:

1. **Type of rotor.** Specifies the type of rotor for which the technical information is being provided.
2. **Nominal capacity of the rotor.** Defines the capacity in litres or litre submultiples. For example: 6 litres; 250 ml, etc.
3. **Maximum speed.** This indicates the maximum speed at which this particular rotor should be operated in revolutions per minutes (RPM).
4. **Maximum Relative Centrifugal field (RCF)** obtained by that type of rotor.
5. **k Factor**, the sedimentation coefficient, defined by the following equation:

$$k = \frac{\ln(r_{\max}/r_{\min})}{\omega^2} \times \frac{10^{13}}{3600}$$

Where:

$\omega$  = angular speed in radians per second

$r_{\max}$  = maximum radius in mm, measured in the centrifugation tube

$r_{\min}$  = minimum radius in mm, measured in the centrifugation tube

The time required for sedimentation can be calculated in hours using this factor.

6. Information on the compatibility of the rotor with other models of centrifuges from the same manufacturer.

Recently manufactured centrifuges have incorporated numerous improvements into their design to provide greater safety and longer operational life. Among advances mentioned are controls based on microprocessors. By means of *software* controlled by a keyboard, these have several different operational programs in memory. According to the type of rotor being used and procedure conducted, these programs control the centrifugation time, the required temperature, the rotor's revolutions, the acceleration and deceleration, alarms warning the operator about any anomaly during operation.

Manufacturers have also incorporated induction motors (without brushes) in centrifuges. These have the advantage of electronically controlling currents and magnetic fields regulating the rotor's speed which reduces the frequency of maintenance. Operation and maintenance of such equipment must be carried out according to the manufacturer's recommendations.

## INSTALLATION REQUIREMENTS

Centrifuges require the following for normal operation:

1. An electrical connection with a capacity suitable for the equipment providing stable single phase or triphase

type voltage (depending on the model and specification given by the manufacturer). In general, centrifuges use 110V or 220 V/60 Hz.

2. A clean, dust free environment with a firm levelled floor.
3. If the centrifuge is refrigerated, it needs a free space on the side of the condenser for adequate heat transfer.
4. A cabinet in which the centrifuge accessories such as the alternate rotors can be kept.

## ROUTINE MAINTENANCE

The routine maintenance required by a centrifuge depends on multiple factors such as the incorporated technology, usage intensity, training of users, quality of the electrical feed and environmental conditions. The following are general recommendations regarding adequate use and most common maintenance for guaranteeing correct operation. The routines or specialized repairs will depend on manufacturers' recommendations for each brand and model. Always disinfect the rotor bowl, centrifuge head, buckets and trunnion rings as applicable before any servicing of centrifuges used to prepare clinical or infectious samples.

Priority recommendation. Verify that only qualified personnel trained and familiar with the use, care, risks and handling of the centrifuge operates it. It is the laboratory directors' responsibility to supervise and take necessary precautions so that personnel operating centrifuges understand the implications of working with such equipment.

## APPROPRIATE MANAGEMENT AND STORAGE RECOMMENDATIONS<sup>1</sup>

### Rotors

1. Register the date of purchase of each one of the rotors, including information related to the serial and model number.
2. Read and understand the rotor manuals, equipment and tubes before use. Comply with indications for use and care specified by the manufacturer.
3. Use rotors only in centrifuges for which these have been manufactured. Do not interchange rotors without verifying the compatibility with the centrifuge.
4. Register operation parameters for each rotor in a log book in order to determine its remaining operational life and to acquire its replacements when needed.
5. Use the recommendations regarding maximum speed and sample density from the manufacturer. Each rotor is designed for supporting a maximum level of effort; these specifications must be followed rigorously.

<sup>1</sup> <http://www.sunysb.edu/facilities/ehs/lab/cs.shtml>

6. Obey the recommendation related to reducing the operation speed when working with high density solutions in stainless steel tubes or plastic adaptors. Manufacturers provide the related information.
  7. Use titanium rotors if working with saline solutions frequently.
  8. Protect the rotors' coating in order to avoid the metal base from deteriorating. Do not use alkaline detergents or cleaning solutions which can remove the protective film. The rotors generally made of aluminium [Al] are covered by a film of anodized aluminium which protects their metal structure.
  9. Use plastic brushes when cleaning the rotor. Metal brushes scratch the protective coating and generate sources for future corrosion. Corrosion is accelerated in operation conditions and shortens the rotor's operational life.
  10. If there are spills of corrosive substances, wash the rotor immediately.
  11. Air dry the rotor once cleaned and washed with water.
  12. Store vertical tube rotors and almost vertical tube rotors with the larger side facing downwards and without their covers.
  13. Store rotors in a dry area. Avoid leaving them in the centrifuge.
  14. Store swinging buckets rotors without the compartments' covers.
  15. Lubricate spiral and O-rings, according to the manufacturer's recommendation.
  16. Observe recommendations related to guaranteed times and operational life of each type of rotor.
  17. Avoid using rotors whose operational lives have ended.
  18. Use a shield if working with radioactive material.
  19. Load or unload rotors inside a biological safety cabinet if working with materials classified as Biosafety level II or higher.
  20. Never try to open the cover of a centrifuge while it is functioning and never try to stop the rotor by hand.
4. Verify if the tubes are reusable or not. If they are disposable, use them only once.
  5. For sterilizing, it is necessary to verify the material from which the tube is made, as not all can stand sterilization by heat. Glass tubes are normally sterilized with vapour at 121 °C for 30 minutes.
  6. Store tubes and bottles in a dark, fresh, dry place, far from chemical vapours or ultraviolet radiation sources.
  7. Verify maximum filling levels and the sealing of thin wall tubes in order to avoid collapse inside the rotor by the action of the centrifugal force. Comply with manufacturers recommendations.

### Preventive maintenance

**Warning:** Never carry out a technical intervention in a centrifuge if it has not been previously decontaminated.

The most important maintenance routines performed on a centrifuge are the following:

#### **Frequency: Monthly**

1. Verify that the centrifuge external components are free of dust and stains. Avoid affecting the rotor with spills. Clean the rotor compartment using a mild detergent.
2. Test that the rotors' connecting and adjustment mechanisms are in good condition. Keep the points lubricated as the manufacturer recommends.
3. Verify the locking /safety mechanism of the centrifuge's cover. This is fundamental in guaranteeing operators' safety as this mechanism keeps the cover of the centrifuge closed while the rotor is turning.
4. Check the lubrication state of elements such as for O-rings as the manufacturer recommends. Always use lubricants according to the manufacturer's instructions (frequency and type of lubricants). In recently manufactured centrifuges, there are sealed ball bearings which do not require lubrication.
5. Verify the state of gaskets and watertight joints.

#### **Frequency: Annually**

1. Verify that electronic cards are clean and well connected.
2. Test operation controls needed for selection of the different parameters of the centrifuge: speed, time, temperature, alarms selectors and analogous or digital instruments.
3. Verify compliance with electrical standards. Use an electric safety analyzer: earth resistance test, escaping current test.
4. If the centrifuge is refrigerated, test the temperature by using an electronic thermometer. The temperature must not vary by more than  $\pm 3$  °C.
5. Examine the exactitude of the time controls. Use a timer. The time measured must not vary by more than  $\pm 10$  % of the programmed time.

### Tubes

Tube care includes aspects such as filling of the tubes, adequate temperature selection, centrifugation speed limitations, washing and sterilization. The principle recommendations are the following:

1. Wash tubes, adaptors and other accessories by hand using a 1:10 mild detergent solution in water and a soft textured brush (not metallic). Avoid using automatic dishwashers.
2. Avoid using alcohol and acetone since such liquids affect the structure of the tubes. Manufacturers recommend the solvent to be used with each type of centrifugation tube material.
3. Avoid drying tubes in a drying oven. Dry always with a stream of hot air.

6. Verify the actual rotation speed against the selected one using a normal load. The testing is done with a tachometer or a photo tachometer. If the hatch is not transparent, the procedure indicated by the manufacturer must be followed.
7. Confirm the functioning of the brake system.
8. Verify the functioning of the refrigeration system in refrigerated centrifuges. The following are the most important activities:
  - a) Check the selected temperatures. These should not vary by more than 3 °C from the temperatures measured on the digital thermometer.
  - b) Verify the state of the air intake filter. If the filter is obstructed, clean or substitute with an equivalent.
  - c) Conduct a detailed cleaning of the diffusing wing of the condenser to eliminate the filth deposited. This maintains the heat transference rate according to the design specifications. If abnormal functioning is detected, seek assistance from a specialized service technician.

**Note:** Avoid spilling liquids on control keys. The keys must be operated with the fingertips: The operator should avoid using fingernails, as this can result in the perforation of their protective membrane.

#### **Every six months:**

Verify the state of the motor's brushes, if the centrifuge has a motor with brushes. Substitute with new ones (with the same specifications as the original) if necessary. Perform this routine every six months.

#### **Tools and required instrumentation**

In order to carry out the maintenance inspections normally required for a centrifuge, the following tools or instruments are necessary:

1. A key for tightening and slackening the rotor's nuts.
2. An electrical safety analyzer or an instrument for measuring escaping current.
3. A timer.
4. An electronic thermometer with exactitude of 0.5°C for refrigerated centrifuges.
5. A tachometer or photo tachometer.

## TROUBLESHOOTING TABLE

<b>Rotors<sup>1</sup></b>		
PROBLEM	PROBABLE CAUSE	SOLUTION
Severe vibration.	The rotor is unbalanced.	Balance the rotor's load. Fill all the opposite tubes with the same level of liquid of same density.
		Distribute the weight of the opposite tubes symmetrically.
		Load fixed angle or vertical tube rotors symmetrically.
	The speed selected is near the rotor's critical speed range.	Select a rotation outside of the critical speed range.
	The rotor is incorrectly mounted.	Verify the rotor's assembly. Test that it is well adjusted.
	There is a lack of lubrication in the rotor's supports.	Lubricate the pivoting axis according to the manufacturer's recommendation. For e.g. each 250 centrifugation procedures.
Rotor covers, canister or cubes difficult to loosen after centrifugation.	A vacuum is being produced during centrifugation.	Open the ventilation line in the upper part of the rotor or bucket to eliminate the vacuum.
	The rings are contaminated with filth, dried lubricants or metallic particles.	Perform routine cleaning of the rings and lubricate. Use recommended products recommended by the manufacturers.

<sup>1</sup> *Rotors and Tubes for Beckman Coulter J2, J6 and Avanti® J series centrifuges, User's Manual, Palo Alto, California, The Spinco Business Center of Beckman Coulter, 2001.*

<b>Tubes</b>		
<b>PROBLEM</b>	<b>PROBABLE CAUSE</b>	<b>SOLUTION</b>
The tubes leak.	The covers are badly secured.	Adjust the covers.
	The tubes are too full.	The meniscus must be lower in order to prevent leaks.
	The maximum recommended level has been exceeded in the open tubes.	Verify the volume and speed recommendations for the centrifugation.
	A deficient seal is presumed in the rapid seal tubes.	Press lightly, after heat sealing (only if the contents are not affected). If leaks are visible, seal again.
The tubes are cracked or broken.	The tubes can be broken or become fragile if they are used below the recommended temperature.	If the sample is frozen, warm to 2 °C before centrifuging. Evaluate how the tubes behave at low temperatures before centrifuging.
	The tubes become fragile with age and use.	Discard expired tubes, use new ones.

<b>Various systems</b>		
<b>PROBLEM</b>	<b>PROBABLE CAUSE</b>	<b>SOLUTION</b>
The main switch is in the on position but the centrifuge is not functioning.	There is no power to the instrument.	Verify the power supply.
The centrifuge cover cannot be opened.	The centrifuge is off.	Turn the centrifuge ON. Press the handle and open the cover.
The balance indicator is activated.	The load to be centrifuged is unbalanced.	Balance the load to centrifuge.
	The centrifuge is not levelled.	Level the centrifuge.
There is a vibration at low speed.	The rotor adjustment mechanism is slack.	Correctly adjust the fastening system.
	The load is unbalanced.	Verify the balance of the load to be centrifuged.
	The selected speed is close to the rotor's resonance point.	Select a more elevated rotation speed or use a different type of rotor.
There are fluctuations in the rotation speed.	The transmission belts are in a bad condition (*).	Turn off the centrifuge. Verify the condition and state of the belts. The belts must be tempered.
The rotation speed does not reach the selected speed.	The brushes are defective.	Turn off the centrifuge. Verify the condition of the brushes. If this is the problem, put new brushes with the same specifications as the originals.
	The speed control calibration is maladjusted.	Adjust the speed control calibration.
The chamber is cold but the rotor is warm.	The temperature is incorrectly selected.	Verify the temperature selection.
The display which signals the state of the brushes is on.	The brushes are in a bad condition.	Turn off the centrifuge. Verify the condition of the brushes. Substitute the brushes by others with the same specification.

(\*) Valid procedure in centrifuges with potential belt transmission system.



## BASIC DEFINITIONS

**Anodized coating.** A hard, thin layer of aluminium oxide, which is deposited on the surface of a rotor by means of electrochemical processes with the aim of preventing corrosion. The coating is often finished in various colours.

**Angular speed.** The turning rate of a body measured in radians per second. It is calculated using the following formula:

$$\omega = \frac{2\pi \times \text{rpm}}{60}$$

Where:

rpm = revolutions per minute

$\pi$  = constant with a value of 3.1416

**Brush.** A device that transmits electrical energy between the external electrical connection (cables in a static state) and the internal components (in rotation) of a motor. In general, brushes are manufactured in very soft textured graphite and, in motors, must be changed regularly (every six months).

**Centrifugal force.** Apparent force equal and opposite to the centripetal force, driving a rotating body away from the centre of rotation and caused by the inertia of the body. It is one of the components of the inertia vector, which equals the set of forces acting on a body. Its magnitude is always  $[m \times a_n]$  and its direction radial, moving away from the centre.

**Density.** A body's mass by volume unit, generally expressed in gram per  $\text{cm}^3$ .

$$D = \frac{m}{V}$$

**Isopycnic separation.** A method for separating particles based on the density of the particle's flotation. It is known as sedimentation in balance. The speed of a particle due to differences in density is given in the formula:

$$v = \left( \frac{d^2 (\rho_p - \rho_c)}{18\mu} \right) \times g$$

Where:

$v$  = speed of sedimentation  $\left( \frac{dr}{dt} \right)$

$d$  = diameter of the particle

$\rho_p$  = density of the particle

$\rho_c$  = density of the solution

$\mu$  = viscosity of the liquid medium

$g$  = gravitational force

**Radian.** A unit of angular measure equal to the angle subtended at the centre of a circle by an arc equal in length to the radius of the circle. It is expressed as the ratio between the arc formed by the angle with its vertex in the centre of the circle, and the radius of that circle.

**RCF (Relative centrifugal field or force).** A relationship between the centrifugal acceleration and a specific speed and radius,  $[r\omega^2]$  given with the normal gravity acceleration. It is calculated by means of the following equation:

$$\text{RCF} = \frac{r\omega^2}{g}$$

Where:

$R$  = radius in mm

$\omega$  = angular speed in radians per second  $\omega = \frac{2\pi \times \text{rpm}}{60}$

$g$  = Standard gravity acceleration = 9 807  $\text{mm/s}^2$

**Resonance.** A situation in which a mechanical system vibrates as a response to a force applied at the system's natural frequency.

**Sedimentation.** Particles from a suspension settling at the bottom of the liquid as a result of the action of the gravitational force. During centrifugation, this process is accelerated and particles move away from the rotational axis.

# Chapter 8

## Water Distiller

<b>GMDN Code</b>	<b>40478</b>
<b>ECRI Code</b>	<b>15-136</b>
<b>Denomination</b>	<b>Distillation units</b>

The word *distiller* comes from the Latin word *distillare* which means to vaporize liquids through heat. The water distiller, also called distillation unit or water still, used in the laboratory, purifies running water by means of controlled vaporization and cooling processes. Upon applying thermal energy to water in a liquid phase by a warming process, it is changed into vapour. This allows the water molecules to separate from the molecules of other substances mixed or diluted. The water vapour is collected and passed through a condenser, where it is cooled and returned to the liquid phase. Then, the condensed water is collected into a different storage tank. Distilled water shows pure characteristics compared to running water; it is practically free of contaminating substances.

### PURPOSE OF THE WATER DISTILLER

The water distiller facilitates obtaining very pure water from potable water normally provided by the aqueduct services in urban centres. Distilled water is characterized by a lack of solids in suspension. It is used in multiple applications in centres which provide health services, especially in laboratory units, in washing, sterilization and dietetics. The more specialized the procedures are in the laboratory, the greater will be the level of purity required. For example: the preparation of reagents or biological material requires water of the highest quality. Distillation is one of the fundamental processes to achieve this (although it may not be the only one required). Water used in laboratories must be free of pyrogens, with a concentration of total solids no greater than 1 ppm, a pH value between 5.4 and 7.2 and an electrical resistance of at least  $3 \times 10^5$  ohm/cm at 25 °C<sup>1</sup>.

<sup>1</sup> *Warming cabinets, sterilizers, and associated equipment*, Division 11–Equipment, USACE/NAVFAC/ AFCEA, UFGS-11710, July 2003.

### DIAGRAM OF A WATER DISTILLER

Figure 21. Water distiller

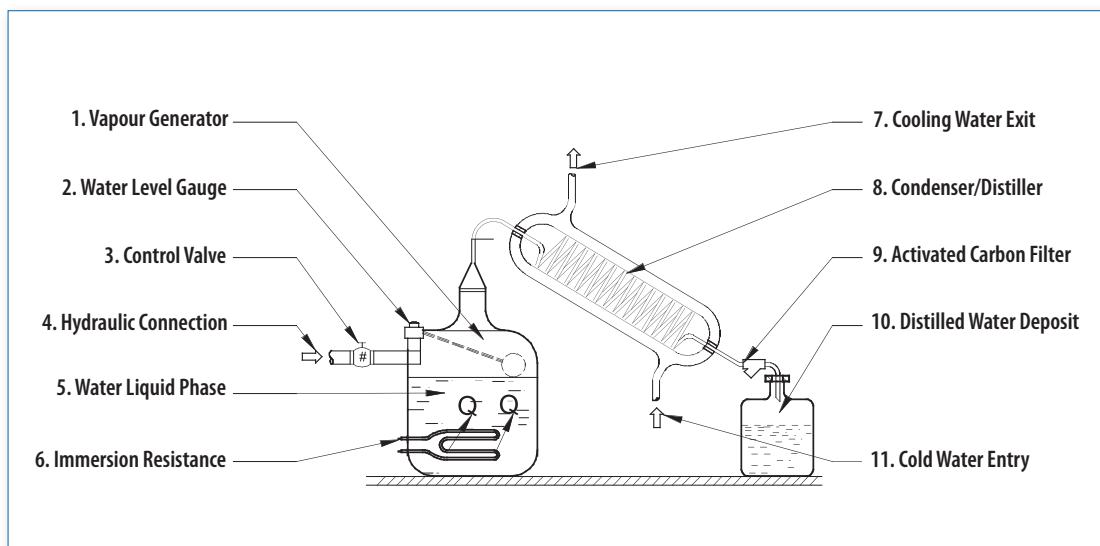

## OPERATION PRINCIPLES

The function of a distiller is based on a phenomenon demonstrated in nature known as the water cycle. The energy coming from the sun heats the water from the seas and transforms part of it into water vapour. This vapour is concentrated in clouds. When atmospheric conditions are suitable, these cool and condense the water which returns to the surface of the Earth in the form of rain.

### Functioning of the water distiller

The water distiller reproduces the natural phenomenon described above. The configuration and design vary depending on the volume of water required. The following is a general explanation of the components of a distiller and a description of how these function.

1. **Vapour generator.** Also known as the boiling tank, this component is the container where the water to be distilled is stored. In general, it has a hydraulic connection which allows the water evaporated and distilled to be replenished. It is generally made of glass in small distillers or of stainless steel with copper, tin or titanium coverings in large capacity machines. It can have level, flow and water quality feed controls, which protect the distiller in case some irregularity in the water supply occurs. As a source of energy, it uses the water vapour coming from a boiler or vapour generator, or the thermal energy from electrical immersion resistors through direct conduction. These cause the water temperature to rise until, in normal conditions (atmospheric pressure equal to an atmosphere and gravity acceleration equal to  $9.80665 \text{ m/s}^2$ ) water in the liquid phase is transformed into vapour at  $100^\circ\text{C}$ .
2. **Water level.** Device which allows the quantity of water to be regulated inside the vapour generator. It is joined directly to the connection which supplies the water used by the distiller. When the quantity of water in liquid phase contained in the boiling tank decreases, the device allows the quantity of liquid evaporated to be recovered.
3. **Control valve.** Mechanical or electromechanical device which allows the flow of water towards the vapour generator tank to be regulated.
4. **Hydraulic connection.** Network which supplies water in liquid phase to the vapour generator tank.
5. **Water in liquid phase.** Water inside the vapour generator tank. It receives thermal energy from the immersion resistors and it is converted to vapour when the required temperature and pressure conditions are met.
6. **Immersion resistors.** Devices generating heat when an electrical current circulates through them. These are isolated by a ceramic cap and protected from the external environment by a metal shield.
7. **Refrigeration water outlet.** Line carrying the water used for condensing the water vapour thus removing the thermal energy from it (cooling).
8. **Condenser.** Device in which the vapour loses thermal energy, cools and returns to its liquid phase. In order to accelerate the process, forced convection by low temperature fluid circulation (air or water) around the line through which the vapour flows is used.
9. **Filter.** Distillers have activated carbon filters located at the exit of the condenser or collector. These eliminate flavours or particles which may be present in the vapour being condensed.
10. **Distilled water container.** Device in which the fluid completing the distillation process is collected. Distilled water must be stored in special plastic containers to avoid ionic contamination. Polyethylene, polypropylene or polytetrafluoroethylene containers are generally used.

## INSTALLATION REQUIREMENTS

Depending on the design, capacity and type of distiller, the required installation may vary. The most common requirements are the following:

1. A well ventilated environment in which the equipment can be installed. This is necessary because the distiller transfers heat to a fluid and increases the temperature of the area where it is installed. It is necessary to leave free space around the distiller so that the flow of air is facilitated. Some distillers are assembled inside a metal box and need to be installed on a support to facilitate the circulation of air under them.
2. A potable water connection. Typically the required hydraulic connection has a diameter of  $1/2''$ . To ensure a smooth operation, the quality of the water feeding the distiller must be evaluated to determine if it is necessary to install a treatment system<sup>1</sup> to prevent the presence of incrustations or sediments in the vapour generating tank and on immersion resistors. Potable water is used for feeding the vapour generator and for refrigerating the condenser<sup>2</sup>.
3. A distilled water connection. The distilled water produced is initially collected into a storage tank. In large capacity equipment, it is distributed to consumption points from the tank by means of a network. In small or medium equipment, it is transferred to containers from which it is used at the feed points.
4. Cleaning connection. This is used to drain impurities which may accumulate in the vapour generator tank using a siphon located near the distiller.

<sup>1</sup> Water treatment has been designed for removing substances normally present in water due to the great solvent capacity of water. The substances in general are inorganic ions (anions and cations) such as bicarbonate, sulphite, chloride, calcium, magnesium, sodium, potassium, magnesium, iron, nitrates and traces of many others.

<sup>2</sup> Some manufacturers cool the condenser through the use of ventilators which make air circulate on the condenser's fins, generating heat transference processes by forced convection from the diffusion surface to the environment.

- An electrical connection equipped with control and safety devices complying with the national and international electrical standards used in the laboratory, adapted to the capacity of the resistive elements of the distiller. In general, the voltage is 220-240 V, 50/60 Hz.

**Note:** Always verify manufacturer's recommendations on installation to ensure the distiller is operating according to the specifications.

## ROUTINE MAINTENANCE

The maintenance depends on the design and capacity of the distiller. The maintenance described in this manual focuses on a distiller equipped with a stainless steel vapour generator tank with immersion resistors and a condenser refrigerated through a ventilator impelling air (on or through the condenser's diffusing fins).

**Warning:** Before carrying out an inspection or routine maintenance, verify that the distiller is turned off and disconnected from the electrical source.

### Inspection and cleaning of the vapour generator tank

#### Frequency: Monthly

- Remove the protective panel or open the door allowing access to the boiling tank or vapour generator.
- Remove the cover of the boiling tank.
- Visually verify if the interior walls or the immersion resistors show solid deposits or sediments. The quantity of deposits present depends on the quality of water fed to the distiller. If there is an accumulation of sediments, it must be cleaned to avoid damaging the resistors<sup>1</sup>.
- Clean accumulated deposits. In general, the cleaning process requires a chemical product especially designed for removing them. The product must be selected according to the characteristics of the water used. This is determined by a chemical analysis.
- Drain water from the generator tank until its level is approximately 10 cm above the location of the water level probe or the immersion resistance (verify that the water level is higher than the base of the tank to ensure that all of the elements stay submerged in water).
- Add the chemical product recommended for the type of water used.
- Mix well.
- Allow the chemical to act overnight or as recommended by the manufacturer.
- Drain the contents of the tank on the following

morning.

- Add clean water, wash and drain until the chemical has been completely removed along with the mineral residues from the affected surfaces.
- Reinstall the cover.
- Place the front panels or adjust the door.
- Operate the equipment normally.

**Warning:** Under no circumstances, should the solution used for removing sediments be distilled.

### Change of the activated carbon filter

#### Frequency: Every three months

Normally, the activated carbon filter is submerged in water below the dispenser system which comes from the distilled water storage tank. It is assembled on a casing installed on the distilled water distribution line. In general, it is a device which can be easily substituted. The following process is generally done:

- Unscrew the top of the filter.
- Remove the used filtering element.
- Install a new element with the same characteristics as the original.
- Reinstall the top of the filter.

**Warning:** The filter is adjusted inside its casing by means of O-rings or gaskets that must be installed carefully within their grooves in order to avoid leaks of distilled water.

### Cleaning of the condenser

#### Frequency: Annually

- In order to clean the condenser, it is necessary to remove the protective panels or open the door, giving access to the condenser.
- Verify that the distiller is disconnected from the electrical outlet.
- Remove the condenser. Disconnect the linkage system for the entry of vapour and the connection which links the condenser to the distilled product storage tank.
- Remove screws joining the ventilator with the condenser. Disconnect the ventilator terminals from its connection points.
- Remove the ventilator and clean the dirt accumulated on the blades. Lubricate the rotation axis with mineral oil (two drops).
- Remove the condenser. Aspirate dirt, dust and fluff accumulated on the surface of the diffusing fins. Compressed air or a brush dampened with soap and water can also be used.
- Rinse the parts.
- Dry.
- Assemble again in the reverse order to that described.

### Sterilization of the distilled water storage tank

<sup>1</sup> The minerals deposited on the cover of the immersion resistors are particularly poor heat conductors in that they impede an efficient transfer of heat between the immersion resistance and the water in the distillation process. This makes the temperature of the resistance rise above that it would reach in normal operating conditions, deteriorating its condition and integrity..

**Frequency: Occasionally**

Before operating a new water distiller, it is recommended to insure that the distilled water storage tank is sterile and clean. To carry out the sterilization, use a chemical process with domestic bleach (chlorine based), for example. The procedure is as follows:

1. Verify that the main switch is off.
2. Open the front panel in order to access the storage tank for the distilled product.
3. Remove the activated carbon filter from its housing.
4. Prepare a chlorine bleach solution with a concentration of 200 ppm and add it to the storage tank.
5. Allow the solution to interact with the tank for at least

three hours.

6. Empty the storage tank using the drainage line.
7. Turn on the distiller and allow the storage tank to be filled with distilled water.
8. Drain the storage tank again.
9. Install the activated carbon filter in its place.
10. Allow the distiller to fill the storage tank with distilled water. The activated carbon filter will remove any remnant of chlorine bleach used.

**TROUBLESHOOTING TABLE**

PROBLEM	PROBABLE CAUSE	SOLUTION
The distiller does not produce distilled water.	There is no energy supply.	Verify that the electric connector is well adjusted in the electrical outlet.
		Confirm that there is power in the circuit feeding the distiller.
Verify that the main switch is in the on position.		
	Test to ensure that there is water in the vapour generator or boiling chamber.	
	The immersion resistance is burnt out.	Verify the integrity of the immersion resistance. Measure electrical continuity or resistance in ohms. Substitute with another that has the same characteristics as the original.
There is water around the distiller.	The distiller or some of its components are incorrectly adjusted.	Test the filter to ensure that the activated carbon is well installed and that water flows through it.
		Verify that the collector tank of condensed liquid is properly placed.
		Confirm that the drainage installation does not have leaks.
There is vapour around the distiller.	The distiller's ventilation is inadequate.	Verify that the distiller has free space around it and at the back.
		Test that there are no objects interfering with the flow of air towards the distiller.
		Remove any object affecting the flow of air
	The refrigeration ventilation does not function.	Verify the condition of the ventilator. If it is turned ON and not functioning, substitute the ventilator with another with the same characteristics as the original.
The distilled water has a flavour.	The carbon filter is worn out.	Replace the activated carbon filter.

## BASIC DEFINITIONS

**Distillation.** A process through which a fluid in liquid phase is heated until converted into vapour and then cooled and condensed back into liquid phase. The distillation process is used for separating mixed substances, taking advantage of their difference in volatility. To obtain very pure substances, consecutive distillation cycles are performed with the aim of progressively eliminating other substances present in the mix.

**Hardness (of water).** A chemical characteristic of water determined by the carbonate, bicarbonate, chlorine, sulphate and occasionally calcium nitrate and magnesium content. The resulting resistance is undesirable in some processes. There are two types of **resistors in water**.

- **Temporary hardness.** This is determined by the magnesium and calcium carbonate and bicarbonate content. It may be eliminated by boiling the water and subsequently filtering out the precipitate. It is also known as *carbonate resistance*.
- **Permanent hardness.** This is determined by all the calcium and magnesium salts, except the carbonates and bicarbonates. It cannot be eliminated by the boiling of water and it is also known as *non-bicarbonate resistance*.

Interpretation of resistance:

Resistance as  $\text{CaCO}_3$  interpretation

0–75 soft water

75–150 water with little resistance

150–300 resistant water

> 300 water with great resistance

In potable water, the maximum limit allowed is 300 mg /l.

In water for heaters, the limit is 0 mg / l.

- **Calcium resistance or hardness ( $\text{RCa}^{++}$ ).** Quantity of calcium present in water.
- **Magnesium resistance or hardness ( $\text{RMg}^{++}$ ).** Quantity of magnesium present in water.
- **Total resistance or general hardness [TH].** Quantity in calcium [Ca] solution and magnesium [Mg] as cations, without taking into account the nature of the anions present in the water. It is expressed as ppm (parts per million) of calcium carbonate ( $\text{CaCO}_3$ ).

**Incrustation (scale).** A name given to solids in suspension deposited in layers on the surface of water storage containers.

**Solution.** A homogenous mix of two or more substances characterized by the absence of chemical reactions between the components of the liquid mixture. The liquid component which generally appears in greater proportion is called the *solvent* and that found in a lesser quantity in solution, the *solute*.



# Chapter 9



## Dilutor

<b>GMDN Code</b>	<b>15133</b>
<b>ECRI Code</b>	<b>15-133</b>
<b>Denomination</b>	<b>Dilutors</b>

The dilutor is used for diluting substances. Dilute comes from the Latin word *diluere* and means to add liquid to a solution. Solutions are defined as homogeneous mixtures of two or more components which may be gaseous, liquid or solid. To dilute is to reduce the strength of a fluid in a solvent, generally water. The dilutor facilitates the preparation of liquid mixtures, until these achieve a proportion (concentration) suitable for use in different diagnostic processes. The identification of this type of equipment is generalized using the word *dilutor*.

### PURPOSE OF THE DILUTOR

The purpose of the dilutor is to prepare mixtures of substances to achieve determined concentrations and volumes as done with a pipette, but with the advantage of an automated or programmed process. Dilutors vary in size and complexity. Their capacity depends on the models and manufacturers. They can control known volumes between 25  $\mu\text{l}$  (microlitres) and 25 ml (millilitres).

### DIAGRAM OF A DILUTOR

Figure 22. Dilutor diagram

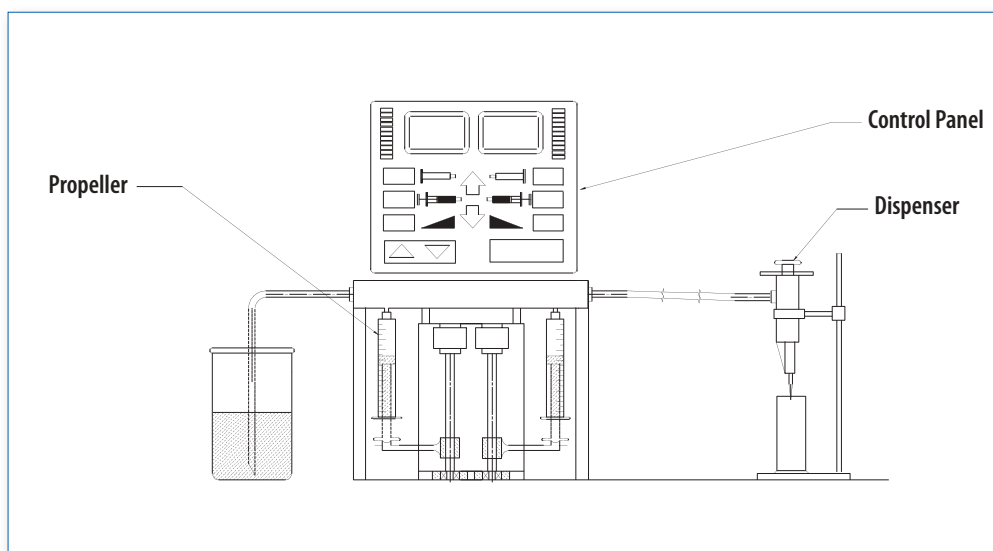



## OPERATION PRINCIPLES

The dilutor has various components which interact in a coordinated manner to handle liquids and mix volumes with great precision, which allows known solutions of between 1  $\mu\text{l}$  and 25 ml to be prepared. The dilutor has in general, the following components:

1. A propulsion system
2. A control system
3. A dispensing system

### Propulsion system

This is generally constituted of positive displacement systems as found in syringes. One or more selectable syringes (with a varying capacity) is/are used in the dilutor to control the volume to be mixed or diluted. The syringes' pistons are moved by a mechanism which controls their position. Aspirated volumes or deliveries are calculated by means of the following equation:

$$\partial V = A \partial l$$

Where:

$\partial V$  = fraction of the volume delivered by the syringe when the piston has a displacement  $\partial l$ .

$A$  = piston area.

The total volume aspirated or delivered is the corresponding integral:

$$V = A \int_{l_0}^{l_1} \partial l$$

where  $l_0$  and  $l_1$  correspond to the positions that define the piston's displacement.

Controlling how the pistons move facilitates good control over the volumes handled. The displacement system is activated by an electric motor which moves a very precise nuts and screws system and changes the position of the piston. A set of valves controlling the aspiration and supply processes complements the syringes and their displacement systems. The configuration of the dilutor depends on the model and manufacturers.

### Control system

Modern dilutors have a control system which is automatic or controlled by microprocessors. The latter allow the following to be selected and controlled:

1. Mixing processes and/or dissolution of substances (programmable)
2. Predefined volume supply
3. Supply or suction velocities
4. Number of required cycles
5. Size or volume of selected syringes
6. Time
7. Priming and cleaning cycles
8. Quality control procedures

In order to give a clearer idea of the technical complexity achieved, a diagram of the control system based on a microprocessor displaying some of the dilutor functions is shown next. The controls for this type of device are generally symmetrical if they control two injectors.

Figure 23. Dilutor controls

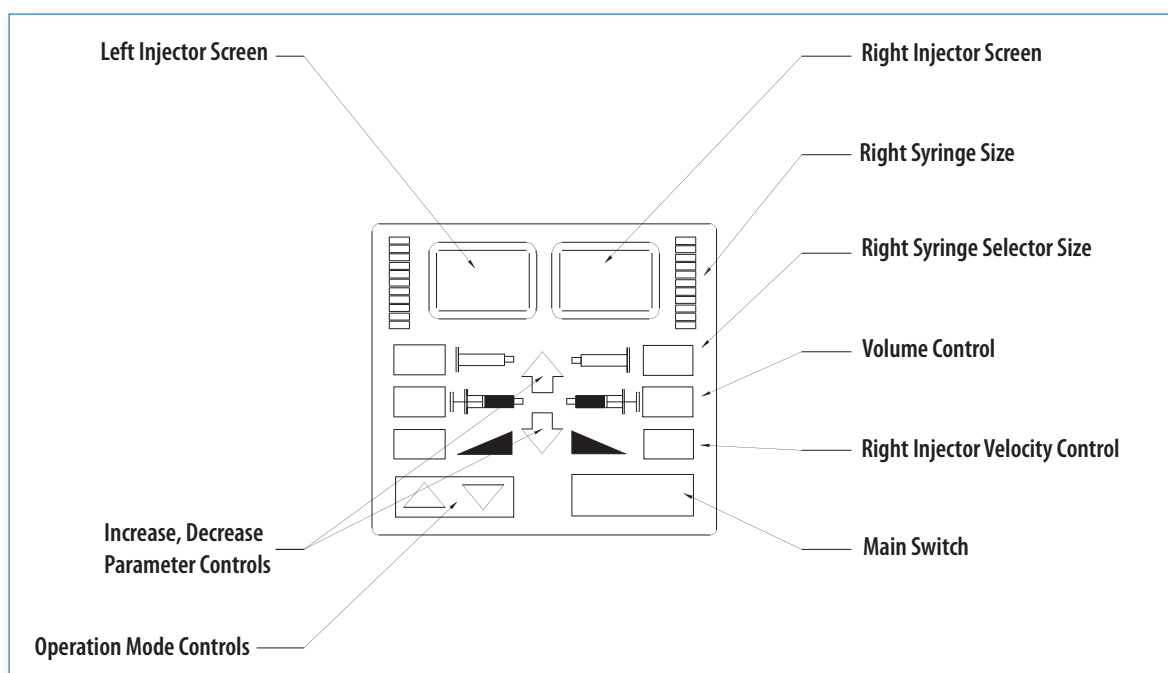

### Dispenser system

The dispenser system is composed of a set of high precision syringes and devices called dispensers, through which fluids are supplied according to their volumes and selected velocities. These syringes are selected and installed in the dilutor depending on the densities, viscosities, and volumes of fluids to be manipulated. The fluids are transported through flexible tubes, whose diameters, lengths and chemical compatibility are taken into account in the design and manufacturing process for suitability with the selected activity. These tubes are linked using connections manually adjustable. Normally, the syringes are classified according to their use (e.g. syringes for reagents, diluents, samples), and the volume these manipulate. The following table shows an example of how they are classified according to their size and managed volumes.

Opposite, the components of the dispensing system (syringe and dispenser) are shown.

### INSTALLATION REQUIREMENTS

The dilutor must be installed on a clean, dry and extremely levelled counter or work surface, far from areas where there may be vapours which can affect its functioning.

There must be free space around the equipment for facilitating ventilation and the passage of cables and interconnection lines and cables with the solvent containers, computers or supply systems. The space around the dilutor should be approximately 10 cm.

There must be a 115 V, 60 Hz electrical outlet in good condition with a ground pole or alternatively one of 220–240 V, 50/60 Hz, depending on the manufacturer’s specifications and/or the electrical norms in the country of use.

Figure 24. Syringe and dispenser

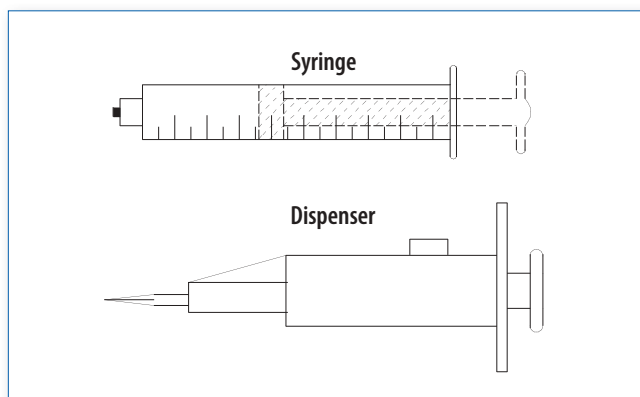

### ROUTINE MAINTENANCE

The routine maintenance focuses mainly on eliminating contaminants which may accumulate inside the fluid mechanisms and/or lines. The most common routines are the following:

#### Cleaning of exterior surfaces

**Frequency: Daily**

**Warning:** Disconnect the dilutor from the electrical feed outlet before beginning the external cleaning process.

1. Clean the exterior surfaces using a clean piece of cloth dampened with a mild detergent mixed with water.
2. Lightly rub the surfaces of the dilutor and the accessories.
3. Dry the treated surfaces.

**Warning:** Avoid humidity from entering the compartment of the electrical and electronic components.

Table of syringe size/volumes managed

Part No. (Depending on the manufacturer)	Model (Depending on the manufacturer)	Syringe size	Range (Processed volume)	Duct size <sup>1</sup>	
				Aqueous solution	Viscous liquids
DM	DM	25 µl	2.5–25 µl	18	18
DM	DM	50 µl	5–50 µl	18	18
DM	DM	100 µl	10–100 µl	18	18
DM	DM	250 µl	25–250 µl	18	18
DM	DM	500 µl	50–500 µl	18	18
DM	DM	1 ml	100–1 000 µl	18	18
DM	DM	2.5 ml	250–2 500 µl	18	12
DM	DM	5 ml	500–5 000 µl	12	12
DM	DM	10 ml	1 000–10 000 µl	12	12
DM	DM	25 ml	2 500–25 000 µl	12	12

<sup>1</sup> Table 2.4, Microlab 501A, 503A, 504A, User’s Manual, Hamilton Company.

### Cleaning of syringes, hoses or lines

**Warning:** If the dilutor has been in contact with dangerous substances, the safety and prevention procedures implemented in the laboratory must be respected.

#### **Frequency: Daily**

1. Feed the system with a cleaning solution. Consult the manufacturer to enquire about the solution to use. Verify that each system's elements come into contact with the solution and that air bubbles have been eliminated. This process is known as *priming*. In order to feed the system, the dilutor is connected to a container in which the used solution is present. Once the priming is complete; the waste solution goes into another container for final disposal.
2. Clean the system. In order to carry out cleaning, a fluid which complements the cleaning solution is circulated (consult the manufacturer's recommendations). It is common to use deionised water as a cleaning fluid. Depending on the substances processed in the dilutor, other cleaning agents can be used such as ethanol, urea, or a 10% bleach solution in deionised water.

### Cleaning of the fluid conduction system

#### **Frequency: Before putting into service for the first time**

1. Prepare a container with cleaning solution and place the filling tube inside (manufacturers recommend using cleaning agents compatible with the dilutor).
2. Place the waste line inside the waste container.
3. Run a feed or priming cycle until the fluid's lines becomes clean.

4. Remove the filling tube from the cleaning solution and place it inside a container with deionised water. Start a feed or priming cycle again until the fluid trajectory is free of cleaning solution. Discard the fluid and rinse the waste container.
5. Suspend the feed cycle.
6. Place the fluid propulsion system in the rest position.
7. Use the system as it is clean and ready.

### Procedure for storing the dilutor

#### **Frequency: Whenever stored for a prolonged period of time**

1. Purge and prime the system using methanol (facilitates drying).
2. Remove the tubes and syringes.
3. Store the syringes in their original protective covers.
4. Cover the body of the dilutor in order to protect it from dust.
5. Store.

### Quality control

The quality control of dilutors is similar to that of pipettes. In order to resolve uncertainties, please see the explanation regarding how calibration is conducted in Chapter 16 on pipettes.

TROUBLESHOOTING TABLE		
PROBLEM	PROBABLE CAUSE	SOLUTION
The dilutor does not turn on.	There is a fault in the electrical feed.	Check the electrical connection.
	The electrical feed is disconnected.	Connect electrical feed cable.
	The protection fuse is open.	Check the protection fuse. Substitute with an equivalent one if it is burnt.
The dilutor operates well, but there are no messages or indications on the screen.	There is possible damage to the LCD screen or in the emission diodes of the LED light.	Verify that the control is well connected to the propulsion system.
		Call the manufacturer's service technician.
The control keys do not function.	The dilutor is on the Pause mode.	Press the start/end button to complete the path of the piston.
The dilute is obstructed.	There is an internal error.	Press the start/end button to complete the path of the piston and to restart the cycle.
		Call the manufacturer's service technician, if the fault persists.
The dilutor does not aspirate nor dispense.	The hydraulic systems' tubes are defective or blocked.	Verify that tubes, syringes and connectors are free from blockages. Clean or substitute.
	Incorrect connection of tubes and syringes	Test that the tubes, joints, connections and syringes used are well adjusted.
	The propulsion system is defective.	Call the manufacturer's service technician.
	The valves are defective.	Remove the valves. Verify that their seals are clean and reinstall. Substitute for an equivalent valve if necessary.
The dilutor does not produce precise results.	There is air in the fluid circuit.	Verify that the feeding tubes are completely submerged inside the containers which contain the reagents.
		Confirm that the different connectors are adjusted.
		Verify that the syringes are correctly installed and there are no leaks.
		Test to ensure that the tubes or valves have no leaks.
		Reduce the operational speed of the syringe to eliminate cavitation problems.
	The delivery tube is incorrectly selected for the syringe's capacity.	Verify the recommended size of the tube used and its connections. For small volumes, use the dimensions recommended by the manufacturer.
A small air gap appears on the tip of the probe after the final aspiration.	The aspiration tube is dirty.	Change or clean the aspiration tube.
	The aspiration mode is incorrect.	Reduce the aspiration speed.
Air is persistently present or there are constant leaks in the fluid trajectory.	Cavitations are present in the system. The aspiration speed is very high.	Reduce the propulsion system's speed. Remember that the more viscous the fluids, the lower the speed must be used to manipulate them.
	The connections are loose, worn out or defective.	Adjust the connections by hand. Substitute to tubes with dimensions corresponding with the fluids processed.
	The piston is defective or the syringe is damaged.	Replace the piston or the syringe.
	There is a defective valve.	Replace the valve.
The dilutor is heating.	There is inadequate ventilation.	Check the ventilation.
	The room temperature is too high.	Check the air conditioning system in the area.
	The work cycle is very intense.	Use the dilutor with less intensity.

## BASIC DEFINITIONS

**Cavitations.** A phenomenon in fluids when a vacuum is created upon emptying a vessel. The pressure decreases until it reaches the vapour pressure of the fluid. This produces diverse phenomena such as vaporization of gases dissolved in the liquid or, in the case of water, the formation of vapour bubbles collapsing after an infinitesimal time lapse, perforating the surfaces of conducts in the immediate vicinity. This occurs in dilutors when using large capacity syringes with elevated propulsion speed.

**Concentration.** A quantity measurement of a chemical substance present in a solution. The concept is expressed as the quantity of a substance dissolved into a solvent. Concentration is expressed in diverse forms; the most common are: molarity [M], molality [m], normality [N], percentage rate of solute.

**Dilution.** To reduce the concentration of a solution by adding other fluids. The fluid added is known as the *diluent*. Adding the molecules of a liquid substance with the molecules of another liquid substance. In order to determine the volume V1 of liquid needed to obtain V2 volume at a concentration C2 from a stock solution of concentration C1, the following equation is used:

$$V_1 = \frac{V_2 C_2}{C_1}$$

**Dispenser.** A device used for distributing liquids.

**Dispensing.** Distributing a fluid at a constant volume or in a progressive form.

**Dissolution.** Process by which a chemical in solid form is dissolved in a solvent (e.g. water or other liquid). The chemical now in solution is called the *solute*.

**Equivalent – gram [Eq].** Mass in grams of solute divided by its equivalent weight [EW]:

$$Eq = \frac{\text{mass(g)}}{EW \text{ (g)}}$$

**Equivalent weight [EW]** (of one substance). Results from dividing the molecular weight [MW] by its valency.

$$EW = \frac{MW \text{ (g)}}{\text{valency}}$$

**Molality [m].** Number of moles of a given substance, for every 1000 g of solvent. Thus an m molal solution is obtained by adding m moles of the substance to 1000 g of water.

**Molarity [M]** (of a solution component). Number of moles of solute for each litre of final solution. A solution n Molar of a salt is obtained by adding n moles from that salt to water until obtaining one (1) litre of solution. Normally, the formula employed is the following:

$$M = \frac{\text{moles}}{\text{Vol(L)}}$$

**Mole.** Molecular weight (MW) of the solute expressed in grams:

$$\text{moles} = \frac{\text{mass(g)}}{EW}$$

**Normality [N]** (of a solute). Number of moles of solute per litre of final solution.

$$N = \frac{Eq}{\text{Vol(L)}}$$

**Solution.** A homogeneous liquid mixture of two or more substances. The dissolved chemical(s) called the solute(s) usually name the solution. The substance in which the solute(s) are now dissolved is called the solvent. There is a usually greater quantity of solvent than solute(s) in a solution.

**Weight/Volume.** Relationship in clinical biochemistry expressing the mass of the solution in grams or its submultiples per volume unit in litres or submultiples of a litre. For example: g/l, mg/ml.

**Note:** Another type of notation known as “part per unit” is used for measuring extremely low concentrations. For example: parts per million (ppm) means that there is a particle of a given substance for each 999 999 particles of other substances.

# Chapter 10

## Dispenser

<b>GMDN Code</b>	41663, 35734
<b>ECRI Code</b>	16-274
<b>Denomination</b>	Dispenser, liquid, laboratory

The dispenser is a piece of equipment in the pipette and dilutor family. The word dispenser comes from the prefix *dis* which implies *privation*, and from the Latin word *pensum* which means *task*. There are different types of dispensers such as, models meeting chemical work requirements and others used in microbiology, bacteriology, immunology and pharmacology. There are automated dispensing units controlled by computer programs, which are used in institutions where there is a high testing demand and thus a need for automated procedures. This chapter features manual dispensers, also called repeater pipettes, as these are the most commonly used.

### PURPOSE OF THE DISPENSER

The dispenser is a multi-purpose piece of equipment which can be used in the laboratory for carrying out the following activities:

1. To aspirate and dispense volumes of liquid or solutions when it does not require great exactitude.
2. To distribute a volume of liquid or solution stored in a recipient container in predefined partial volumes (repetitive dispensing with a constant final volume).
3. To mix a solution by successive aspiration and delivery, using an aspiration and supply device.
4. To titrate a solution or a virus stock by dispensing the material to be titrated by serial dilution into a diluent until reaching the end point.

### PHOTOGRAPH AND DIAGRAM OF THE DISPENSER

#### Dispenser



Photo courtesy of Gilson S.A.S.

Figure 25. Dispenser

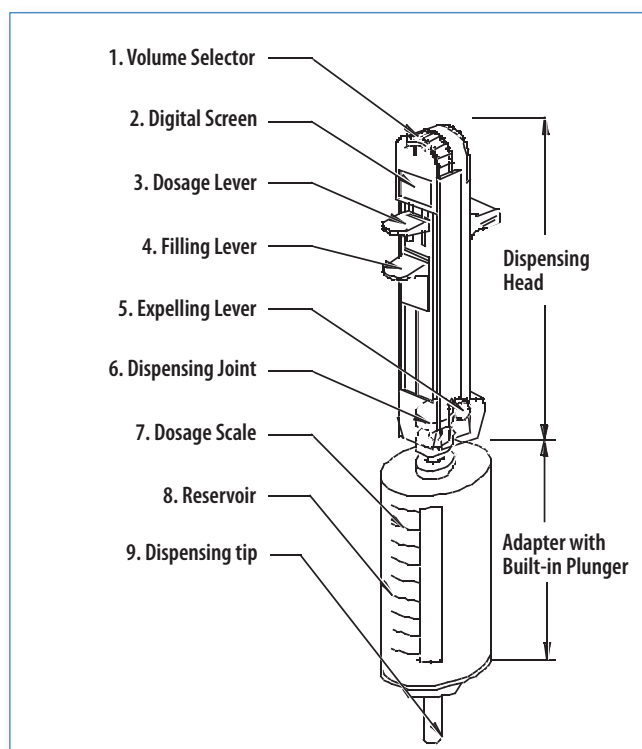

5. To dilute the concentration of a solution by mixing defined volumes of this solution with a diluent.
6. To use similarly to a pipette (by aspirating a volume and then dispensing it).
7. To distribute the culture mediums in Petri dishes. Automated dispensers equipped with accessories for moving the Petri dishes and storing them once the culture medium is dispensed are often used. Precise application (small scale) of culture medium is done using disposable plastic syringes with N° 16<sup>1</sup> needles.

The dispenser can normally be programmed for such activities according to the manufacturer's instructions provided.

### Operation principles

In general, modern dispensers are controlled by microprocessors and have the following components (Note that the numbering below corresponds to that in Figure 25).

1. Volume selector. This thumbwheel is used to regulate the volume to be dispensed. The selection made is shown on the dispenser's screen.
2. Digital screen. This shows the data related to the selected function, such as selected volume, type of tip present on the dispensing head and information related to alarm and error messages that may be generated during operation e.g.: low battery or incorrectly selected tip for the volume selected.
3. Dosage lever. This lever activates the plunger attached to a syringe-like positive displacement adaptor, in which a piston is activated along a cylinder to dispense the selected volume of liquid.
4. Filling lever. A mechanical lever manually activated to aspirate the liquid into the adaptor's reservoir.
5. Eject button. A mechanism that releases the dispensing element (adaptor) from the dosing device head.
6. Dispenser connector. This is the offshoot connecting the setting element to the dispenser head. It contains a system of gaskets and guides for ensuring its adequate adjustment.
7. Dosage scale. This shows the maximum volume that can be dispensed with the selected adaptor. In some cases, it also indicates the remaining volume.
8. Dispensing adaptor. A container which holds the solution aspirated or supplied in dispensation cycles. There is a great variety, depending on the model of dispenser. There are simple or combined ones with adapted tips.
9. Dispensing tip. This facilitates supplying or drawing solutions. The tip is located at the end of the dispenser's adaptor. Without it, it is impossible to use the dispenser.
10. An on and off switch. (Not shown in the figure).
11. A battery compartment. (Not shown in the figure).

### Dispenser's accessories

For the dispenser to perform specific tasks, the appropriate accessories are needed. Examples of adaptors are shown in the figure below.

<sup>1</sup> Product Information Sheet. 3cc Syringes. For dispensing and plating Methocult®. [http://www.stemcell.com/technical/28230\\_28240-PI5.pdf](http://www.stemcell.com/technical/28230_28240-PI5.pdf)

Figure 26. Dispenser and accessories

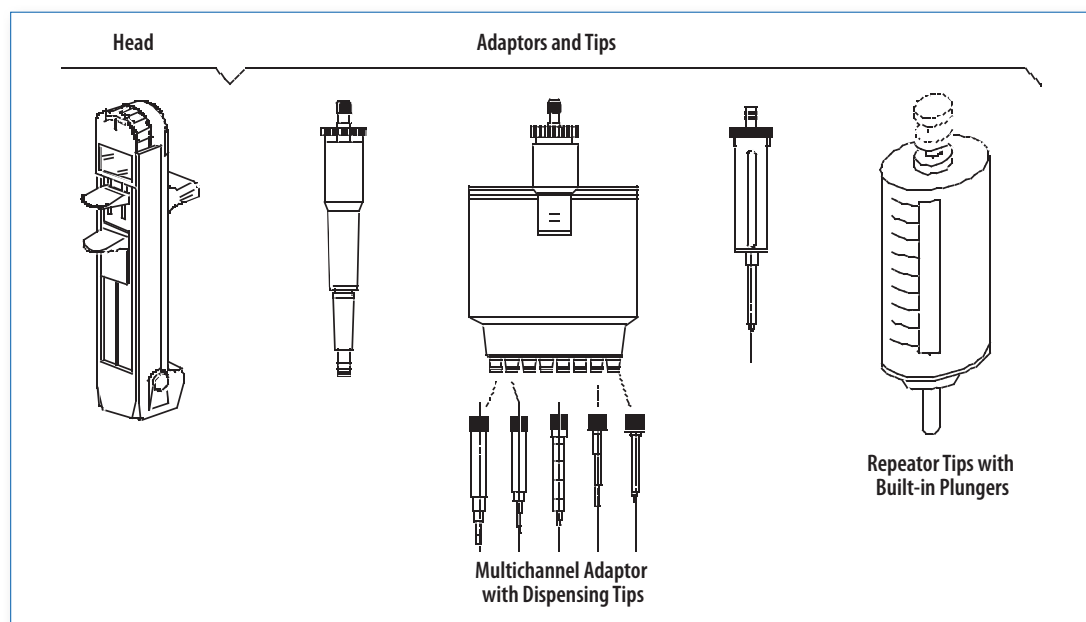

### Dispensed volume

Dispensers have been developed for working with predefined volume ranges. Before use, the type of solution to be used and volumes to be dispensed will have to be considered. Manufacturers offer diverse models of adaptors. A table with typical work ranges is shown next.

Adaptor capacity	Volume ranges dispensed
0.1 ml	1–20 µl
0.2 ml	2–40 µl
1 ml	10–100 µl
5 ml	50–500 µl
10 ml	100 µl to 2 ml
25 ml	250 µl to 5 ml

### REQUIREMENTS FOR OPERATION

Depending on the type of dispenser, minimum conditions are required for operation, some of which are as follows:

1. Verify that the dispenser has been designed for the solutions to be used. Verify the compatibility of materials in the user manual provided by the manufacturer.
2. A clean environment, equipped with suitably sized work stations, well ventilated and lit.
3. Verify that the room temperature is stable, with a variation range of  $\pm 0.5$  °C, between 4 and 40 °C and an optimum temperature of 20 °C.
4. Use the appropriate personal safety protection if working with toxic materials or materials posing a biological risk.
5. Use tips specifically designed by the manufacturer for each particular application.

### ROUTINE MAINTENANCE

The maintenance of the dispenser is simple. The routines detailed below feature the most important activities:

#### **Frequency: Daily**

1. Clean the dispenser with a damp cloth and mild detergent.
2. Disinfect the dispenser using 60% isopropanol.
3. Prevent humidity from entering the interior of the electronic control and/or the mechanisms.

#### **Battery change (as needed)**

1. Open the battery compartment. This is generally done by simply sliding the lid from the “closed” position to the “open” position.
2. Remove the worn out battery. Dispose of it according to recommendations.
3. Install a battery with the same characteristics as the original. Verify the electrical polarity so that it is properly installed. Before inserting it, clean the contact surface with a piece of clean cloth.
4. Close and adjust the lid.



TROUBLESHOOTING TABLE		
PROBLEM	PROBABLE CAUSE	SOLUTION
It is not possible to install the adaptor in the dispenser's head.	The component is defective.	Seek assistance from a specialized service technician.
	The dispensing component is contaminated.	Observe if there is some type of obstruction. Clean if necessary. Seek help from the specialized service technician.
The adaptor cannot be removed from the dispenser's head.	There is a failure in the electronic system.	Reinitiate the equipment. (Switch off and on). Select manual extraction option.
	There is a failure in the adjustment mechanism.	Verify if the piston moves forward and backwards. Remove the cylinder over a waste container.
The tip of the dispensing device (adaptor) drips.	The tip is defective.	Substitute the dispensing device.
The pipette type dispensing device drips.	The dispensing tip is not well adjusted.	Free the dispensing tip from the adjustment cone. Adjust firmly.
	The dispensing tip was incorrectly selected.	Verify the type of tip recommended by the manufacturer.
	The piston or piston seal is damaged.	Replace the piston and seals. Use replacement parts supplied by the manufacturer.
The screen shows the low battery signal.	The battery is worn out.	Replace the battery.
The screen does not show any signals.	The battery is worn out.	Replace the battery.
	The electronic system is defective.	Seek the assistance of a specialized service technician.
The screen shows error signals.	Various	Seek the assistance of a specialized service technician.
The screen shows a filling error.	Insufficient liquid for the dispenser.	Verify that the volume available for dispensing is adequate. If not, load or aspirate a volume adequate for the quantity to dispense.
The screen shows complete volume error.	More liquid was aspirated than the adaptor or tip is able to receive.	Eject all liquid. Check operation attempted again.
The screen shows tip selection error.	The tip installed is not designed for carrying out the operation attempted.	Verify what type of tip is designed for performing the operation. Substitute the tip.
	The tip is defective.	Place a new tip with the same specifications as the original.

## BASIC DEFINITIONS

**Culture medium.** Liquid or solid material developed for medical purposes for cultivating and identifying microorganisms capable of producing diseases (pathogens) and for various other purposes.

**Dispensing element (adaptor).** Devices also called Combitips, attached to the dispensing head to dispense a solution. Different sizes and shapes are available according to the volumes to be dispensed and the characteristics of the solution used.

**Petri dish.** A shallow plate made out of glass or plastic used for microorganism cultures in the laboratory.

**Mix.** Addition of substances which does not produce a chemical reaction. In a homogenous mixture, the composition and appearance must be uniform.

# Chapter 11



## Spectrophotometer

<b>GMDN Code</b>	36411	36411	36411
<b>ECRI Code</b>	15-082	15-083	15-084
<b>Denomination</b>	Spectrophotometer, ultraviolet	Spectrophotometer, ultraviolet, visible	Spectrophotometer, visible

The word *spectrophotometer* is derived from the Latin word *spectrum*, which means *image*, and the Greek word *phos* or *photos*, which means light. The spectrophotometer is one of the main diagnostic and research instruments developed. It uses the properties of light and its interaction with other substances. Generally, light from a lamp with special characteristics is guided through a device, which selects and separates a determined wave length and makes it pass through a sample. The light intensity leaving the sample is captured and compared with that which passed

through the sample. Transmittance, which depends on factors such as the substance concentration is calculated from this intensity ratio.

### PURPOSE OF THE EQUIPMENT

The spectrophotometer is used in the laboratory for determining the presence or concentration of a substance in a solution, thus allowing a qualitative or quantitative analysis of the sample.

### PHOTOGRAPH OF SPECTROPHOTOMETER

#### Conventional spectrophotometer



Photo courtesy of Beckman Coulter

### OPERATION PRINCIPLES

As a basic principle, light is considered to be a form of electromagnetic energy. In space, it has a constant and universal velocity [C] of approximately  $3 \times 10^8$  m/s. In any other medium (transparent) through which light passes, its velocity will be slightly lower and can be calculated by the following equation:

$$v_0 = \frac{C}{n}$$

Where:

$v_0$  = Velocity at which light passes through the medium

$n$  = Medium refraction index: whose value oscillates, in general, between 1.0 and 2.5.

The electromagnetic energy has a very wide range of wavelengths. Some examples are shown in the following table:

Type of electromagnetic energy	Range of wavelength
Radio waves	From a few meters to a few kilometres
Radar waves	From 1 to 10 cm
Infrared waves	From 1 to 10 microns ( $10^{-6}$ m)
Visible light	From 300 to 700 nm (nanometres)
X rays	From 0.1 to 0.5 Å (Angstrom)
Gamma rays	Approximately 0.0012 Å (Angstrom)

Upon passing or interacting with diverse mediums, light undergoes a series of phenomena. Among these are featured reflection, refraction, diffraction, absorption, diffusion, polarization and other phenomena measured by various instruments and devices. The table below shows the wavelength ranges used for carrying out spectrophotometry tests.

Section of the lighting spectrum	Range of wavelength
Ultraviolet	10–200 nm (nanometres)
Near ultraviolet	200–280 nm
Visible light	380–780 nm
Near infrared	780–3 000 nm
Mid infrared	3 000–20 000 nm
Far infrared	30 000–300 000 nm

With regard to the interaction of light with matter, Figure 27 assists in clarifying the complexity of phenomena that occur.

The diagram in Figure 27 shows that the incidental radiation [ $I_o$ ] can undergo a series of transformations. It can be reflected [ $I_r$ ], transmitted [ $I_t$ ], diffused [ $I_d$ ], absorbed and directly emitted as fluorescence [ $I_f$ ]. The phenomena on which spectrophotometry is based are mainly absorption and transmission. In order to understand how, it is necessary to take Beer Lambert's law into account.

Beer Lambert's Law. Also known as Beer's law or Beer Lambert Bouguer's law, it identifies the relationship between the concentration of the sample and the intensity of light transmitted through it. With regard to the law mentioned, there are two implicit concepts: transmittance [ $T$ ] and absorbance [ $A$ ].

The transmittance [ $T$ ] is the fraction of the incidental light of determined wavelength passing through the sample.

$$T = \frac{I_t}{I_o}$$

Where:

$I_t$  = intensity of the transmitted radiation

$I_o$  = intensity of the incidental radiation

Figure 27. Interaction of light with matter

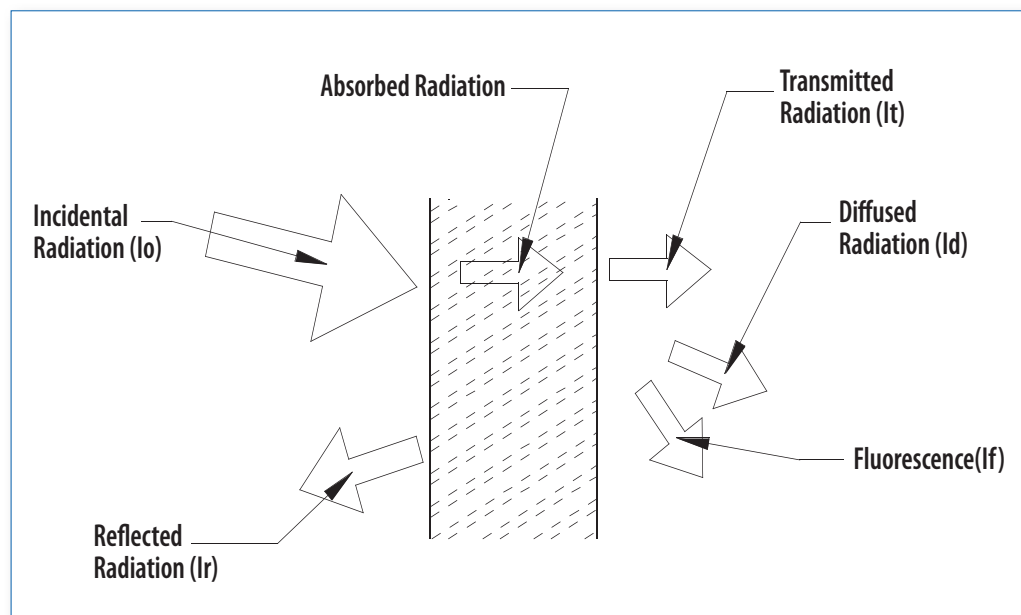

The percentage of transmittance [%T] can be expressed by the following equation:

$$\%T = \frac{I_t}{I_o} \times 100$$

The concentration of light absorbing molecules in a sample is proportional to the absorbance [A] of that sample. It is expressed mathematically as:

$$A = \epsilon \times l \times c$$

Where:

A = Absorbance measured

$\epsilon$  = Molecule absorbance coefficient  
[litres/moles/cm]

l = Distance of the trajectory traversed (path length)  
by the light in the sample

c = Sample concentration [moles/litres]

Absorbance [A] is related to transmittance [T] through the following equation:

$$A = \log_{10} \frac{1}{T} = \log_{10} \frac{I_o}{I_t} = \log_{10} 10^{\epsilon \times c \times l} = \epsilon \times c \times l$$

The following diagram explains the phenomenon of absorbance:

**Figure 28. Absorbance phenomenon**

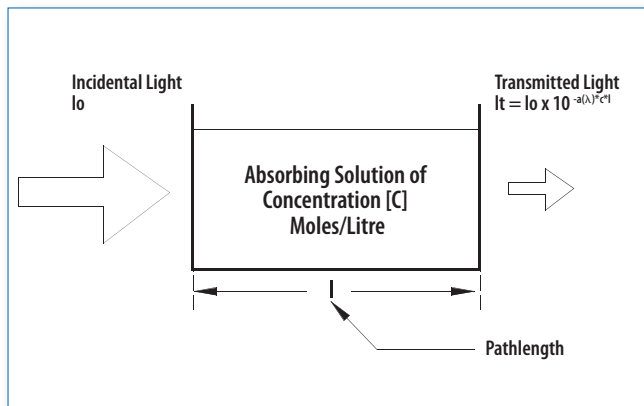

The graphs presented next demonstrate how absorbance [A] and transmittance [T] vary as a function of the concentration [C] according to Beer Lambert's law.

#### Transmittance graph

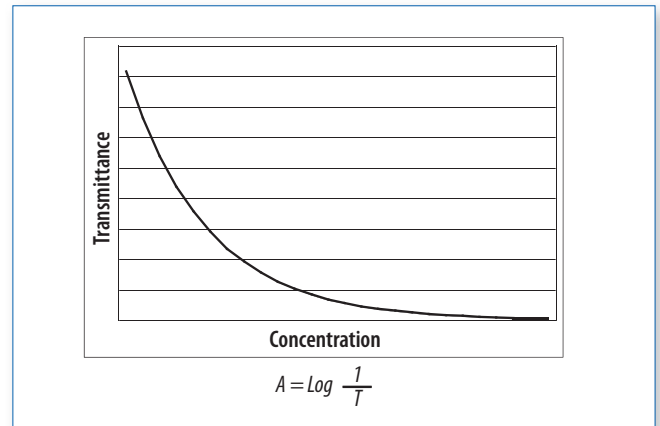

#### Absorbance graph

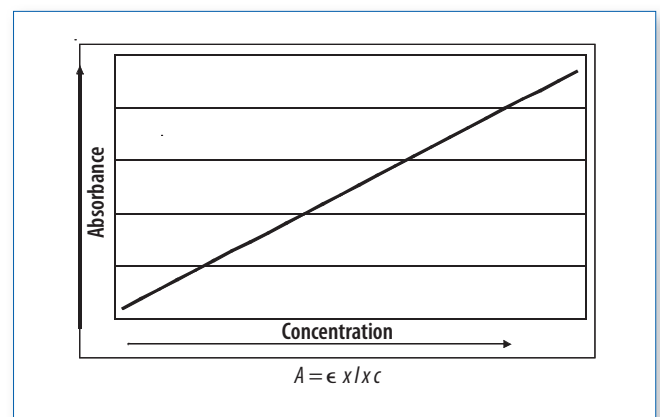

In conclusion it can be inferred that by increasing the concentration of a substance, the transmittance is decreased and, upon increasing the concentration of the substance, absorbance is increased.

The linearity of Beer Lambert's law is affected if the following conditions occur.

1. Displacement of the sample's chemical balance as a function of the concentration.
2. Deviations in the absorbance coefficients, greater concentrations than 0.01 M due to electrostatic interaction between nearby molecules.
3. Changes in the refraction index at high concentrations of the analyte.
4. Diffusion of light due to particles in the sample.
5. Fluorescence or phosphorescence of the sample.
6. Non-monochromatic radiation.

## SPECTROPHOTOMETER COMPONENTS

The diagram shown in Figure 29 describes the relationship between the different components of a spectrophotometer. The most important are the following.

1. The light source
2. The monochromator
3. The sample carrier
4. The detector system
5. The reading system

These are the basic spectrophotometer components, not covering novel technology incorporated by manufacturers in advanced models. A brief explanation of these basic parts is shown in Figure 29.

### Light source

Depending on the type of spectrophotometer, the light source can be a tungsten lamp for visible light or a deuterium arc lamp for ultraviolet light. Some manufacturers have designed spectrophotometers with long lasting xenon intermittent lamps emitting light in the visible and ultraviolet ranges. The lamp(s) come factory-assembled on a base that ensures a fixed position, to maintain optical adjustment and focus when operating or when replacing the bulb. The typical radiating energy emitted from a tungsten lamp is between 2600 and 3000°K (Kelvin degrees).

### Monochromator

The monochromator is a set of elements used to disperse white light into waves of different wavelengths, one of which is used in the sample reading. In general, it has an entry crevice or groove which limits the light radiation produced by the source and confines it to a determined area; a set of mirrors for transmitting light through the optic system; an element for separating the light radiation wavelengths (which may be a prism or a diffraction (or transmission) grating); and an exit opening for selecting the wavelength

required to illuminate the sample. Diffraction gratings have the advantage of eliminating the non-linear dispersion and being insensitive to changes in temperature.

### Sample holder

This device holds the sample(s) to be analysed. There are various sample holder types to accommodate different spectrophotometer models and sample volumes: these come as cuvettes, microcells, microplates, test tubes and continuous flow cells, etc. In conventional spectrophotometers, the holder is a cell or cuvette of rectangular shape. Cuvettes are made of glass to read in the range of 340 to 1000 nm and others of silica to read in the visible range of 220 to 340 nm. There are also cuvettes and other sample holder types (e.g. microplates) in plastic such as styrene or polystyrene which are disposable.

### Detector system

The detection system can be designed with photocells, phototubes, photodiodes or photomultipliers. This depends on the ranges of wavelength, the sensitivity and the required speed of response. The detection system receives light from the sample and converts it into an electrical signal proportional to the energy received. This electrical signal can be processed and amplified to be interpreted by the reading system. A summary of advantages and disadvantages of devices normally used in detection systems is included in the following table (see opposite).

### Reading system

The signal which leaves the detector goes through various transformations. It is amplified and transformed until its intensity becomes a proportional transmittance/absorbance percentage. There are analogous reading systems (displaying results on a reading scale) or digital ones (showing results on a screen).

Figure 29. Spectrophotometer components

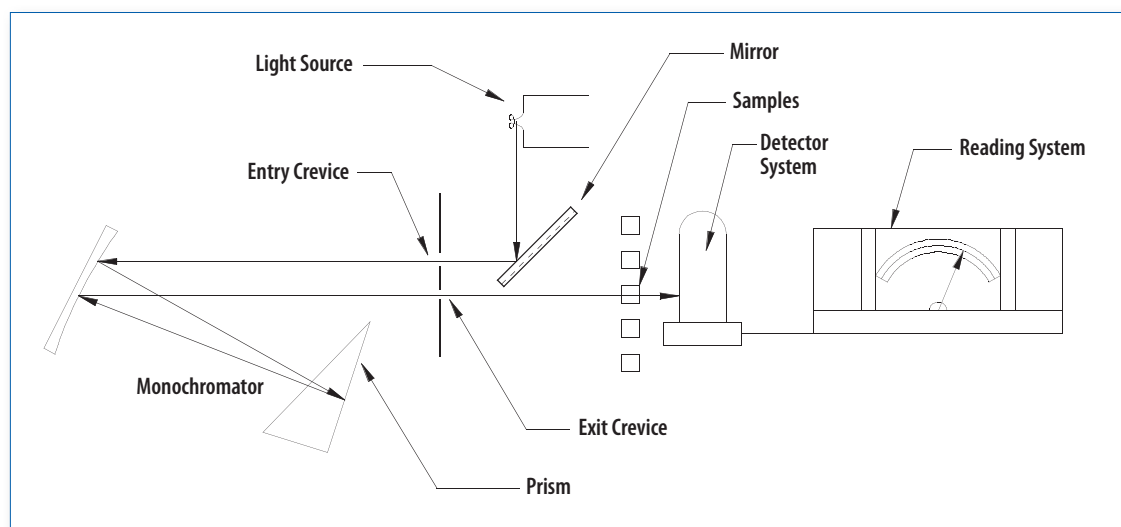

**Advantages and disadvantages of common detection devices**

Device	Advantages	Disadvantages
Photocells	Economic.	Limited wave lengths between 400 and 750 nm.
	Small.	Low sensitivity.
	Robust.	Respond slowly to change in light intensity.
	Do not need energy sources nor signal amplifiers.	Wear out. Signal is dependent on the temperature.
Phototubes	Function between 190 and 650 nm. Also between 600 and 1000 nm.	Require calibrations depending on the temperature of the environment where the equipment is installed.
		Wear out with high levels of illumination.
Photodiodes	No movable mechanical parts.	
	Acquire spectral data simultaneously.	
	Wide dynamic range.	
	Excellent reproducibility of wavelengths.	
Photomultipliers	More sensitive than phototubes and photocells.	Can burn if day light penetrates them while in operation.
	Work on wider ranges of wavelengths.	Very expensive.
	Rapid responses to changes in light intensity.	Need a high voltage source.
	Do not become worn out like photocells.	Used only in specialized spectrophotometers.
	Can be made with sensitivity in the whole range of ultraviolet and visible light. (From 190 to 900 nm).	

Analogous indicators traditionally bear the name *meters*. Their exactitude depends among other factors, on the length and the number of divisions of the scale (the more divisions, the more exact it is). Their main disadvantage is that they can be incorrectly read, due to the operators' fatigue or errors identifying scales when there are several.

Digital indicators usually show results on a screen as illuminated alpha numerals. This makes reading errors less likely.

**INSTALLATION REQUIREMENTS**

For the correct functioning of a spectrophotometer, the following is required:

1. An electric supply source that complies with the norms and standards used in the country. In American countries, voltages of 110 V and frequencies of 60 Hz are generally used. Other parts of the World require 220-230V/50-60 Hz.
2. A clean, dust free, environment.
3. A stable work table away from equipment that generate vibrations (centrifuges, agitators).

**SPECTROPHOTOMETER MAINTENANCE**

Spectrophotometers are very specialized and costly equipment. Their integrity depends to a great extent on the way they are installed and used. Their direct environment and the quality of the electricity services constitute factors of prime importance for the equipment to function according to specifications. Routine maintenance required vary in complexity, ranging from careful cleaning of components to specialized procedures carried out by a trained specialized technician or engineer with the technical information for different manufacturers' models and designs. Following manufacturer's instructions and careful use will guarantee a prolonged operational life. In recent models, manufacturers have incorporated automatic routines of calibration and verification.

In this document general maintenance recommendations applicable to a wide range of spectrophotometers are presented. It is emphasized that specialized routines can only be performed according to the specific manufacturer's recommendations for each particular model. General routine maintenance for a spectrophotometer in good condition and the frequency of estimated checks are as follows:



### Inspection of the instrument's surroundings

#### Frequency: **Annually**

The area in which the spectrophotometer is installed must be inspected visually and tested electrically in order to guarantee the safety of the operator. The inspection covers the electrical installation and the installation area (physical infrastructure related to the spectrophotometer).

#### Electrical installation

It must be verified and tested for ensuring the following:

1. There is an electrical outlet or receptacle with a ground pole.
2. The receptacle is in good condition and is no further than 1.5 m from the spectrophotometer.
3. The voltage is of an appropriate level and must not vary by more than 5% of the voltage specified on the equipment's plate.
4. The receptacle's polarity is correct.

These tests must be done by an electrical technician or an engineer and results must be recorded to allow follow-up over time.

#### Installation area

1. Check that there is free space around the spectrophotometer for two purposes. First, for the connecting cables to pass without hindrances and for other components or support equipment (e.g. the voltage stabilizer). Second, to allow adequate ventilation of the equipment when it is in operation.
2. Test the integrity of the counter, its state and cleanliness.
3. Verify that there is no equipment installed that can transmit vibrations in proximity. (E.g. centrifuges).
4. Verify that it is not affected by excessively humid conditions, dust or high temperatures. The appropriate room temperature for the operation of the spectrophotometer generally ranges between 10 and 40 °C.
5. Avoid installing the equipment where it receives direct solar radiation.
6. Do not install the equipment where there are magnetic fields or intense electromagnetic radiation.
7. Ensure installation area is free from the influence of gases and corrosive substances.

### Visual inspection of the equipment

#### Frequency: **Every six months**

The spectrophotometer must be inspected visually to verify that the state and integrity of its components are maintained in accordance to the manufacturer's specifications. The most important aspects are cited next:

1. Check that the structure of the work table supporting the spectrophotometer is in good condition.

2. Test the general structure of the spectrophotometer. Verify that buttons or control switches and mechanical closures are mounted firmly and that their identification labels are clear.
3. Ensure that accessories are clean, not showing cracks and that their functional state is optimal.
4. Confirm that mechanical adjustment parts (nuts, screws, bolts, etc.) are adjusted and are in good condition.
5. Check that electrical connectors do not have cracks or ruptures, that they are joined correctly to the line.
6. Verify that cables are not showing signs of splicing, that they are not frayed and that they do not have worn-out insulation.
7. Check that cables securing devices and terminals are free of dust, filth or corrosion. These same cables must not be worn out or show signs of deterioration.
8. Check that the grounding system (internal and external) is standardized, of approved type, functional and correctly installed.
9. Ensure that circuit switches or interrupters, the fuse box and indicators are free from dust, filth and corrosion.
10. Check the external electrical components for signs of overheating.

### General maintenance

#### Cleaning of spills

In case of a leak in the sample holder or carrier, the spill must be cleaned according to the following procedure:

1. Turn off the spectrophotometer and disconnect the cable from the electrical feed.
2. Use a syringe for cleaning the sample holder. Absorb as much liquid that can possibly be extracted.
3. Dry the sample holder with a medicinal cotton bud.
4. Use lens paper or a clean piece of soft textured cloth for cleaning the window of the photocell.
5. Clean the exterior of the instrument with a piece of cloth moistened with distilled water. Include the screen, control and keyboard in the cleaning.

#### Cleaning of quartz cuvettes

It is recommended to carry out the following procedure to maintain quartz cuvettes in good condition:

1. Wash the cuvettes using a diluted alkaline solution such as NaOH 0.1 M and a diluted acid such as HCl, 0.1 M.
2. Rinse cuvettes several times with distilled water. Always use clean cuvettes to take absorbance measurements.
3. Conduct rigorous and careful cleaning procedures on cuvettes if samples used can deposit films. Some manufacturers recommend using special detergents for cleaning cuvettes.

#### Battery changes

Various models of spectrophotometers use batteries to memorize data associated with the analysis, such as date and time. The procedure to change the battery is similar

in the various equipment. Following this procedure is recommended:

1. Verify that the low battery indication appears on the instrument's screen.
2. Turn off the spectrophotometer.
3. Disconnect the electrical feed cable.
4. Open the battery compartment and remove the worn-out batteries.
5. Clean the electrical contact points.
6. Install new batteries with the same specifications as the originals.
7. Close the compartment.
8. Reconnect the equipment.
9. Adjust the date and time information.

### **Change of bulb/lamp**

The bulb is a consumable with a limited operational life. It must be foreseen that at some point in time, it will be necessary to replace it. Most likely it will burn out, or suffer from internal metallization and evaporation and the light emitted will no longer meet the spectrophotometric processes specifications. Lamp change steps differ for each model and one must always follow the manufacturer's instructions. Common steps are as follows:

1. Verify that the bulb is not functioning or that there is some indication of flaw. In modern equipment, a sign will appear on the screen or an error code. In old equipment, the light will simply no longer work.
2. Turn off the spectrophotometer.
3. Disconnect the feed cable.
4. Undo the screws securing the top of the lamp's compartment.
5. Undo the screws keeping the lamp's mechanism fixed.
6. Undo the screws fastening the electrical connection cable to the lamp (in some equipment, this might not be necessary, as the assembly base has direct contact mechanism to the lamp's contact terminals).
7. Install a new lamp with the same characteristics as the original. Use gloves to avoid getting fingerprints on the surface of the lamp.
8. Reconnect the electrical feed cables to the lamp.
9. Reinstall the screws keeping the lamp in place.
10. Replace the screws securing the lamp's compartment's cover.
11. Reconnect the spectrophotometer.
12. Turn the equipment ON and carry out the equipment's recalibration procedure stipulated by the manufacturer.

### **Preventive Maintenance**

Preventive maintenance of the spectrophotometer must correspond with routines and frequencies recommended by the manufacturer. A series of basic routines which can be performed in the laboratory is presented next:

1. Clean the spectrophotometer externally, including the controls, screens or measurement meters. This can be done using a piece of fine cloth (similar to the texture used in handkerchiefs) dampened with distilled water.
2. Inspect and clean the electrical feed cable.
3. Verify that the lamp is clean and in good state. If it is not functioning, install a new one with the same specifications as the original. In modern spectrophotometers, the lamp's state is detected automatically by software which controls the state and functioning of the equipment making it easy to determine when it is necessary to change the lamp. Change the lamp and carry out the subsequent adjustments following the manufacturer's recommendations.
4. Check the protection fuse. Before opening the compartment where the fuse is housed, check that the spectrophotometer is turned off and check that its contacts are clean and in good condition. If it is necessary, replace by a new one with the same characteristics as recommended by the manufacturer.
5. Put the instrument in the operational configuration.
6. Activate the "on" switch and allow it to warm up for five (5) minutes. Verify that:
  - a) The lights or pilot indicators work.
  - b) The reading indicators stay on zero (0).
  - c) The light source works.
7. Carry out an escaping current test in the "on" and "off" position.
  - a) Verify the ground pole and the correct polarity.
  - b) Verify the correct polarity without a ground pole.
  - c) Verify the inverse polarity without a ground pole.
8. Calibrate the front panel of the spectrophotometer according to the manufacturer's instructions.
9. Measure the equipment's sensitivity.
10. Conduct a test according to Beer's law.
11. Return the spectrophotometer to the initial configuration if the calibration has been successfully completed.

### **GOOD PRACTICES WHEN USING THE SPECTROPHOTOMETER**

1. Calibrate the spectrophotometer every time a set of samples is to be analysed.
2. Keep the cover of the sample holder and compartment closed during the measurement process to ensure adequate reading.
3. Avoid reusing disposable cuvettes.
4. Only use quartz cuvettes for carrying out analysis under 310 nm.
5. Avoid the use of plastic cuvettes if using organic solvents.
6. Use high quality boron silicate glassware for preparing standards. Avoid the use of sodium glass (sodium oxide) whenever possible, as prolonged contact with standards can permeate it and produce erroneous results.



7. Carefully clean the glass cuvettes after use. Discard those that show lines on the clear surface.
8. Use high quality reagents. Those of low quality can cause contamination even in very low concentrations. The diluents used (water or solvents) must be free of impurities.
9. Verify that samples or standards did not degas inside the cuvettes. This phenomenon produces bubbles on the inner surface of the cuvettes and causes errors in the readings.
10. Take into account that not all substances comply with Beer's law. Carry out linearity tests on the range of concentrations to be used. It is recommended to

prepare a group of known high standard solutions and verify the results. The phenomena that affects Beer's law are the following:

- a) High concentration by molecular association of ionic species.
- b) Variation in hydration at low concentrations changing the nature of complex ions.
- c) Absorptions that do not comply with the Beer law require graphing results of known standards. This will indicate reading versus the concentration such that the reading of the unknown concentrations can be related to concentrations from the graph.

**TROUBLESHOOTING TABLE**
**Automated spectrophotometer<sup>1</sup>**

PROBLEM	PROBABLE CAUSE	SOLUTION
The spectrophotometer is without power.	The on and off switch is in the off position.	Move the switch to the on position.
	There is no electric energy in the feed outlet.	Verify the general electric feed. Test that some safety mechanism has not misfired.
	The electric feed cable is not connected well.	Connect the feed cable firmly.
The keyboard's buttons do not respond.	The initialization of the equipment during start-up is incomplete.	Turn off the equipment and switch on again.
	An incorrect command was activated during start-up.	
The serial port RS 232 does not respond.	There was incomplete initialization of the equipment during start-up.	Turn off the equipment and switch on again.
	The interconnection cable is badly connected.	Verify the connection.
The LCD screen is difficult to read.	The contrast control is maladjusted.	Adjust the contrast.
	The base lighting system burnt out.	Call the representative.
The printer is blocked.	There is a paper jam in the printer.	Remove the excess paper with finely pointed tweezers.
		Turn off the equipment, remove the paper and reinstall again.
The printer's paper does not auto feed or advance.	The printer paper is installed erroneously.	Turn off the equipment, reinsert the roll of paper.
	The front edge of the paper is not aligned or folded.	Turn off the equipment. Reinsert the roll of paper. Cut the front edge and realign in the feed system.
	The paper feed control does not respond.	Call the representative.
The cuvette does not enter the sample holder compartment.	The cuvette is of the wrong size.	Use the size of cuvettes specified by the manufacturer.
	The cuvette's adjustment mechanism is incorrectly placed.	Correct the position of the adjustment mechanism.
The reading shows fluctuations.	There are interferences in the light path.	Verify that the cuvette is not scratched.
		Verify that there are no particles floating in the cuvette.
		Rub the optic walls of the cuvette with a piece of clean cloth.
		Verify that the working range selected is appropriate for the sample under analysis.
The reading shows negative values. There is no absorbance reading.	There is no sample.	Add a sample to the solution.
	The cuvette is incorrectly positioned.	Verify the orientation of the cuvette's window.
	The wavelength is erroneously selected.	Adjust the wavelength to the range compatible with the analysis.
	The equipment was erroneously calibrated with a sample instead of a blank solution.	Calibrate with a blank solution or with distilled water.

<sup>1</sup> Instruction Manual, Spectrophotometer, SmartSpec™ 3000, BIO-RAD Laboratories.

<b>Non-automated spectrophotometer<sup>1</sup></b>		
<b>PROBLEM</b>	<b>PROBABLE CAUSE</b>	<b>SOLUTION</b>
The source lamp does not light-up.	The filament is broken.	Replace the lamp.
	The safety fuse is burnt out.	Replace the lamp.
	There is resistance in the lamp's filament.	Replace the lamp.
	The voltage is erroneous.	Review the voltage. Check the feed source.
Low readings in the meter or in the galvanometer.	The source lamp is defective.	Replace the lamp.
	The photocell is dirty or defective.	Clean or replace the photocell.
	The amplifying circuit is defective.	Change or repair the amplifying circuit.
	The source lamp's voltage is low.	Adjust the voltage.
Unstable indication of the measurer.	The Zener diode stabilizer is defective.	Replace the Zener diode.

<sup>1</sup> Operation seminar workshop and Maintenance of Spectrophotometers, Maintenance Subregional Project, RE-HS-02, OPS/OMS Agreement.

## BASIC DEFINITIONS

**Absorption.** A physical phenomenon occurring when atoms or molecules of a substance absorb light (photons). The energy of a photon is taken up by another entity, e.g. by an atom whose valence electrons change between two electronic energy levels destroying the photon in the process. The energy absorbed is lost through heat or radiation. **Absorbance** is a mathematical measure of absorption, expressed in **optical density units (OD)**.

**Angstrom.** A unit of length equal to  $10^{-10}$ m. Its symbol is [Å]. It is used for carrying out measurements of X- or Gamma-rays.

**Band width.** A wavelength range that a monochromator can transmit.

**Diffraction.** Phenomenon caused by a change in the directions and intensities of a group of waves after reaching an obstacle, or through a narrow aperture whose size is approximately the same as the wavelength of the waves.

**Diffraction grating.** A component of the monochromator, also called “transmission grating”. It diffracts light and is shaped as a series of parallel fissures carved onto a reflecting surface. It is made by tracer machines protected against vibrations and temperature variations. Gratings used in spectrophotometers are copies of one master grating that usually has more than 1200 fissures per millimetre. Figure 31 demonstrates the phenomenon of diffraction.

If the reflection angle [ $\delta$ ] is known as well as the width [ $d$ ] of the fissures, the wavelength [ $\lambda$ ] can be determined according to the following equation:

$$\sin \delta = \frac{n\lambda}{d}$$

**Intensity [ $I_v$ ].** The amount of light emitted by a source in a particular direction per unit of time. More generally, a measurement of the average energy flow per unit of time. To get the intensity, the energy per unit of volume is multiplied by the speed at which the energy moves. The resulting vector is the energy by square surface per unit of time.

**Molar extinction or absorptivity coefficient [ $\epsilon$ ].** Measures how strongly a chemical species absorbs light at a determined wavelength. It is an intrinsic property of the chemical species. When there is more than one absorbing species in a solution, the absorbance is the sum of the absorbance values for each individual species. The absorbance at a given wavelength of a mixture of species X, Y ... is given by

$$A = \int [C_x \times \epsilon_x + C_y \times \epsilon_y + \dots]$$

Where A is the absorbance of the mixture.

**Nanometre.** A unit of length corresponding to  $10^{-9}$  m (a thousand millionth of a metre). It is identified by the symbol [nm]. It is used for measuring visible or ultraviolet light wavelengths.

**Path length.** The distance covered by visible or ultraviolet light through a sample in an analytical cell (cuvette or well).

**Refraction.** A change of direction that occurs when a ray of light reaches the interface between two media.

The light cuts at an angle [ $a$ ] and refracts at an angle [ $b$ ] upon changing propagation medium.

**Figure 30. Refraction of light**

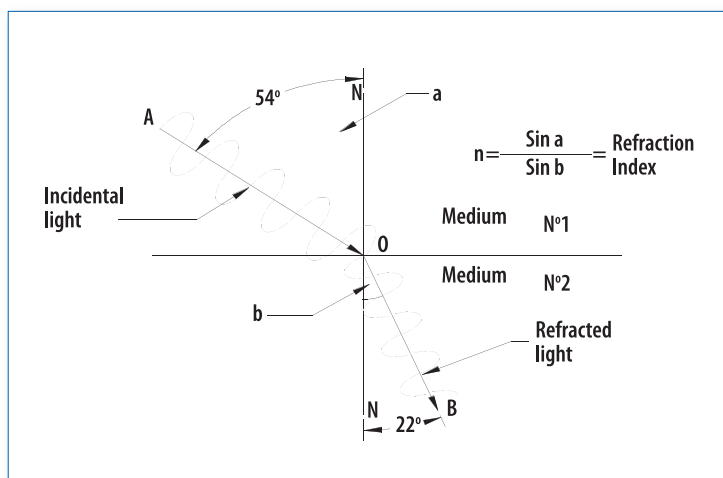

**Spectrophotometry.** A method of chemical analysis based on the absorption or attenuation of light of a specified wavelength or frequency by matter. The light interacts with specific features of the molecular species being analyzed: the light absorbed depends on the wavelength, the concentration of the species and the trajectory. This allows determining properties such as the concentration of substances, which in the field of basic health, serves to perform a multitude of analysis for determining the health status of a patient.

**Wavelength.** The distance between crests of a wave. It determines the nature of the different forms of radiant energy in the electromagnetic spectrum. For electromagnetic waves, the wavelength in meters is calculated by the speed of light divided by frequency (number of peaks passing through a certain point in a determined time).

**Figure 31. Diffraction grid**

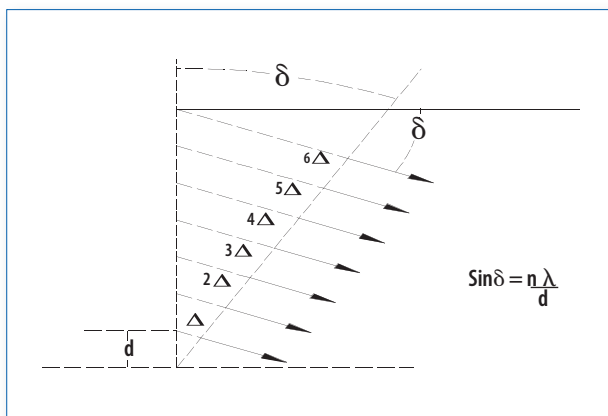

$\Delta$  = difference in wavelength between two adjacent slots (fissures).

# Chapter 12

## Autoclave

<b>GMDN Code</b>	<b>35366</b>	<b>35366</b>	<b>35366</b>
<b>ECRI Code</b>	<b>13-746</b>	<b>16-141</b>	<b>16-142</b>
<b>Denomination</b>	<b>Sterilizing unit, steam</b>	<b>Sterilizing unit, bulk</b>	<b>Sterilizing unit, tabletop</b>

The autoclave is a piece of equipment used for sterilizing. The word sterilizing means the destruction or elimination of all forms of life (microbial, including spores) present in inanimate objects by means of physical, chemical or gaseous procedures. The word *sterilizer* comes from the Latin word *sterilis* which means not to bear fruit. This chapter will focus exclusively on autoclaves as these are greatly used in public health establishments, clinical and research laboratories. This type of equipment is also known as a sterilizer. Sterilization must be considered as a group of very important interrelated processes for carrying out health services, (sterilization of materials, culture medium, instruments) within rigorous conditions of asepsis. The processes associated in achieving sterile conditions of inanimate objects are the following:

### PHOTOGRAPH OF AUTOCLAVE



Photo courtesy of SysTec GmbH

1. Cleaning
2. Decontamination
3. Inspection
4. Preparation and packing
5. Sterilization
6. Storage
7. Delivery of materials

### PURPOSE OF THE AUTOCLAVE

The autoclave is equipment designed with the aim of reliably eliminating<sup>1</sup> microorganisms, which would otherwise be present on objects used in diagnostic activities, in treatment or surveillance in health institutions (hospitals, laboratories). It is also widely used in the food processing and pharmaceutical industries. In the laboratory, materials and objects are sterilized for the following purposes:

1. To prepare materials for bacteriological cell cultures (test tubes, pipettes, Petri dishes, etc.) in order to avoid their contamination.
2. Prepare elements used for taking samples. (All must be in sterile conditions: needles, tubes, containers).
3. Sterilize contaminated material.

Autoclaves are available in many sizes. The smallest are the table-top type and the largest are complex equipment that require a great amount of pre-installation for their operation. The volume of the sterilization chamber is taken as a reference and measured in cubic decimetres [dm<sup>3</sup>] or in litres [l] in order to measure the autoclave's size. Depending on how their operation is controlled, it is possible to find manual, semiautomatic or fully automatic models.

<sup>1</sup> The Food and Drug Administration (FDA) classifies sterility of an article based on statistical studies. An article is considered sterile if the probability of encountering it not sterile in a set of articles submitted to the same process of sterilization, is less than one in a million. This index is called Sterility Assurance Level (SAL) and describes the theoretic potential of microbial inactivation in a sterilization process.

**OPERATION PRINCIPLES**

Autoclaves work by taking advantage of the thermodynamic properties of water which can be considered as a pure substance. In normal conditions (at sea level and pressure of 1 atmosphere) water (in liquid phase) boils and is converted into vapour (gaseous phase) at a 100 °C. If the pressure is reduced, it boils at a lower temperature. If the pressure rises, it boils at a greater temperature. Through the control of water vapour pressure, the autoclave can, in its sealed chamber, reach temperatures higher than 100 °C; or inversely, by controlling the temperature, can achieve pressures greater than atmospheric pressure. The following graph demonstrates the behaviour of water depending on conditions of pressure and temperature.

Autoclaves use pressurized saturated vapour (with a quality greater than 98%) for transmitting thermal energy to elements that require sterilization. In general, this method is known by the terms *steam* or *moist heat sterilization*. This is the sterilization method mostly used due to its effectiveness, rapidity and low cost. However, not all materials can be sterilized with moist heat; for those elements that are affected by heat and humidity, alternative methods of sterilization have been developed. In the laboratory, in order to carry out sterilization processes, steam autoclaves as well as drying ovens using dry heat (without the presence of humidity) are used. See Chapter 13: *Drying ovens*.

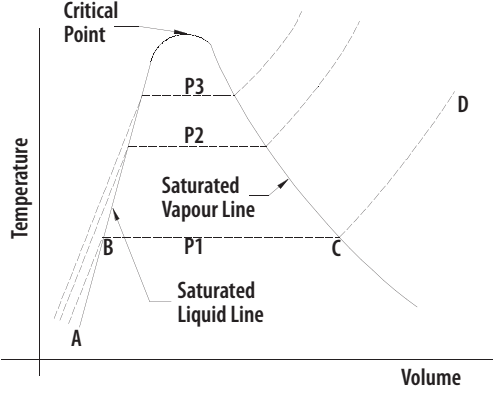
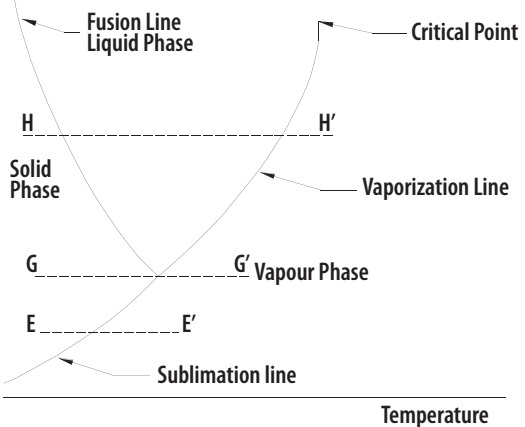
Temperature / Volume Graphic	Pressure / Temperature Graphic
 <p>The graph plots Temperature on the y-axis and Volume on the x-axis. It shows two curves: the Saturated Liquid Line on the left and the Saturated Vapour Line on the right. These two lines meet at the Critical Point. Three horizontal dashed lines represent different pressure levels: P1 (lowest), P2 (middle), and P3 (highest). Point A is on the liquid line at pressure P1. Point B is on the liquid line at pressure P2. Point C is on the vapour line at pressure P1. Point D is on the vapour line at a higher pressure than P1.</p>	 <p>The graph plots Pressure on the y-axis and Temperature on the x-axis. It shows three phase transition lines: the Fusion Line (between Solid and Liquid phases), the Vaporization Line (between Liquid and Vapour phases), and the Sublimation line (between Solid and Vapour phases). The three lines intersect at the Critical Point. Horizontal dashed lines represent constant temperature conditions: E-E' (sublimation), G-G' (fusion), and H-H' (vaporization).</p>
<p>1. This graph shows two defined lines: the saturated liquid (to the left) and the saturated vapour (to the right) lines.</p>	<p>1. This graph shows the behaviour and relation between the solid, liquid and gaseous phases of water depending on the pressure and temperature conditions.</p>
<p>2. As the pressure increases, so does the temperature. (See lines P1, P2, P3) where: P3 &gt; P2 &gt; P1.</p>	<p>2. The sublimation lines show that at determined conditions, if heat is transferred to the solid phase, it can be converted directly into the vapour phase (section E-E'), without going through the liquid phase.</p>
<p>3. To the left of the saturated liquid line, the water is in a liquid state (plot A-B). Upon heat transfer, the temperature of the liquid is raised from Temperature A to B.</p>	<p>3. The fusion line shows that at determined conditions, upon transferring heat to water, the solid phase is transformed into the liquid phase and, if more heat is added, it is transformed to the vapour phase (section H-H').</p>
<p>4. Between the line of saturated liquid and saturated vapour (section B-C) there is a mixture of the vapour and liquid phases, and the temperature remains constant. The closer it is to point C, the greater is the vapour's quality<sup>1</sup>.</p>	<p>4. The vaporization line shows at which temperature conditions the water in liquid phase is transformed into the vapour phase.</p>
<p>5. To the right of the saturated vapour line, all the water is in vapour phase (section C-D).</p>	<p>5. The point at which the three lines are intercepted is called the Triple Point. In such circumstances the three phases exist simultaneously in equilibrium.</p>

<sup>1</sup> Quality [X]. The relationship between total vapour mass and total mass (liquid mass plus vapour mass). Quality = 1: means that the vapour is saturated and that any increase in temperature will overheat the vapour.



### Cross-section diagram of the vapour autoclave

Figure 32 shows the main components of the vapour system of an autoclave. For clarity, parts normally located around the autoclave (their precise location depends on the manufacturer), have been included on top and at the bottom of the autoclave diagram.

### Description of the components in the diagram

A brief description of the most common elements of the vapour circuit of an autoclave is given next. The same number identifying each component is used in Figure 32 and its description below. Note that the configurations vary depending on each manufacturer's design.

1. **Safety valve.** A device that impedes the vapour pressure from rising above a determined value. The manufacturers install these in the sterilization chamber as well as in the jacket.
2. **Chamber manometer.** A mechanical device that indicates the vapour pressure in the sterilization chamber.
3. **Jacket manometer (pressure gauge).** A mechanical device that indicates the vapour pressure inside the autoclave's jacket.
4. **Autoclave door.** A device which allows the sterilization chamber to be isolated from the outside environment. It normally has safety devices that prevent it from opening when the chamber is pressurized. It also has seals for preventing vapour from leaving the chamber when the equipment is in operation. Autoclave doors can be manually or electromechanically operated.
5. **Door handle.** A device which in some equipment, allows the operator to open and close the door. The larger capacity equipment in general has motorized mechanisms for activating the door.
6. **Sterilization chamber.** The space where objects or materials to be sterilized are placed. When the door is closed, the chamber remains isolated from the exterior. When the sterilization process is in progress, it is filled and pressurized with vapour.
7. **Chamber condensation evacuation line.** A duct that allows the collecting of condensation formed in the sterilization chamber as a consequence of the heat transference processes between the vapour and objects being sterilized.
8. **Thermometer.** An instrument that indicates the temperature at which the sterilization processes in the autoclave chamber is done.
9. **The jacket's condensation evacuation line.** A duct that allows the extraction of condensation formed in the casing as a result of heat transference between the vapour and the jacket's walls.
10. **Vapour exit at the end of the cycle.** When a sterilization cycle is finished, vapour is extracted from the autoclave by controlled procedures.
11. **Vapour passage restriction for liquid sterilization cycle.** A mechanical device that restricts the passage of vapour during a liquid sterilization cycle to allow the temperature to decrease in a controlled manner and to prevent sterilized liquids from boiling.

Figure 32. Vapour circuit of an autoclave

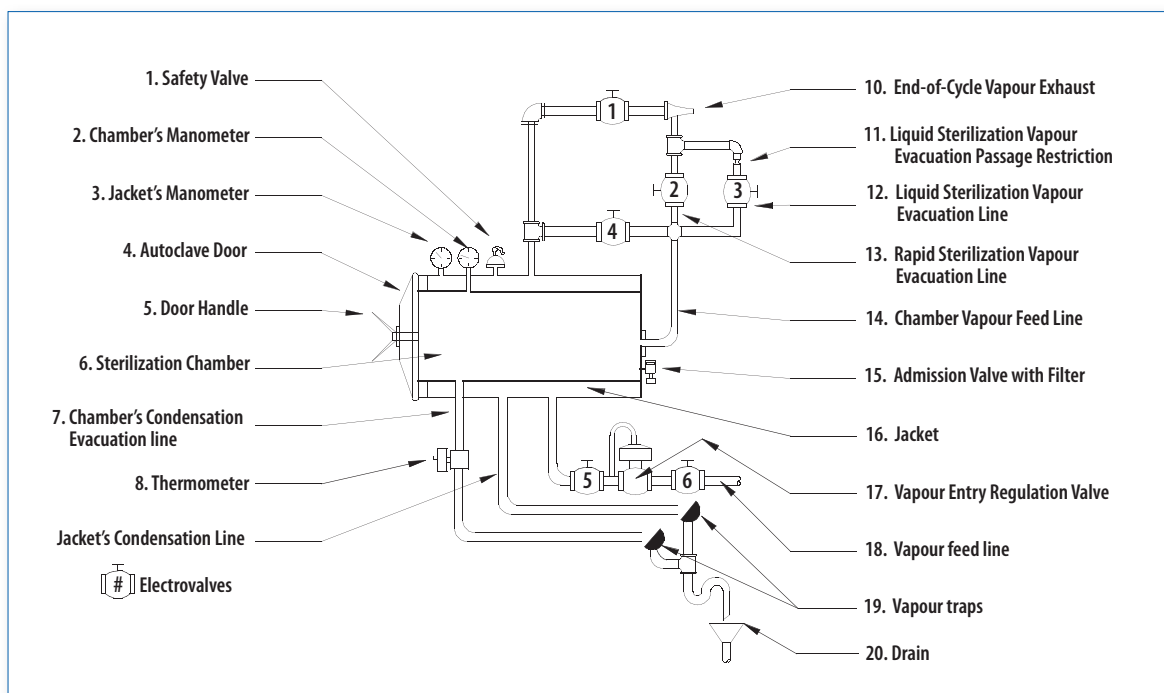



12. **Vapour evacuation duct for sterilization of liquids.** A path followed by vapour when a liquid sterilization process is being conducted and which passes through the restriction described above.
13. **Vapour evacuation line during the rapid sterilization cycle.** A path that follows vapour when a rapid sterilization cycle is being carried out.
14. **Vapour feed line.** A conduct that feeds the autoclave with vapour. This line has controls and accessories that enable vapour to reach the autoclave at the conditions stipulated for the sterilization cycle.
15. **Air admission valve with filter.** A device that allows the entry of filtered air upon finishing the sterilization cycle. The valve homogenizes the pressure of the sterilization chamber to that of the atmosphere.
16. **Jacket.** A space located around the sterilization chamber in which vapour circulates. Its purpose is to transfer heat to the chamber and lessen the formation of condensation. It is connected to the chamber and to the drainage through lines controlled by electrovalves. Not all autoclaves have jackets. Some manufacturers substitute it by placing electrical resistors around the sterilization chamber.
17. **Vapour entry regulation valve.** It is a mechanical device which controls the pressure at which vapour enters the autoclave. Depending on the cycle selected, the pressure and the temperature will be different. The greater the pressure, the greater the temperature. The lesser pressure, the lesser the temperature.
18. **Vapour feed line.** A duct that brings vapour from the boiler or the vapour generator to the autoclave.
19. **Vapour trap.** A device designed to take maximum advantage of vapour's thermal energy. Its function is to prevent vapour from leaving the system. The trap only allows condensed liquid formed in the chamber, jacket and autoclave conducts to leave.
20. **Drain.** A collection line for the condensed liquid produced in the autoclave to exit.

Nowadays, autoclaves use microprocessor-controlled systems and each one of their valves and accessories work in accordance with pre-established programs stored in their memory. Operations remain recorded in a registering system, which allows the different stages of the sterilization to be checked. Each manufacturer has incorporated registering systems which are indispensable for quality control.

**Vapour production.** The vapour autoclaves use is generated in devices which transfer thermal energy to water using electrical energy or fossil combustible. These are called boilers or vapour generators and constitute a fundamental component of the autoclave. Depending on their size and the frequency of use, autoclaves have vapour feed systems that originate from a central system of boilers or from their own vapour generator. These generally function

with electrical resistors and come already incorporated into the equipment or are supplied as an accessory by the manufacturers.

## OPERATION OF THE AUTOCLAVE

The general operation of an autoclave is described next. Some procedures will vary according to the degree of automation incorporated into the equipment:

1. Verify that the registering system has forms and/or paper required for documenting the development of the sterilization cycle. Supply any missing element (ink, form, etc.).
2. Turn the autoclave ON.
3. Open the door of the autoclave. In large capacity autoclaves, this process is done electromechanically. It is often manual in medium and low capacity autoclaves.
4. Place the sterilization baskets or containers containing the previously prepared material (cleaned, washed, dried, classified and packaged) into the sterilization chamber, according to the manufacturers' recommended distribution instructions.
5. Close the door of the autoclave<sup>1</sup>.
6. Select the required sterilization cycle depending on the type of objects or materials to be sterilized<sup>2</sup>. In general, a labelled button corresponding to the cycle required is pressed and automatically initiates the programmed cycle. From this moment on, the process proceeds as indicated next<sup>3</sup>:
  - a) The pre-treatment phase is initiated. In this phase, short alternate cycles of emptying and injecting of vapour into the sterilization chamber are performed so that air is extracted from it and packets protecting the material are sterilized.
  - b) When the air has been removed, filling and pressurization of the sterilization chamber is initiated. At this time, the vapour enters into contact with objects to be sterilized and a process of heat transference is initiated between high temperature vapour and articles to be sterilized. Upon transferring thermal energy, a portion of vapour is converted into liquid water (condensed liquid) in the exterior layers of the material used for packing, simultaneously decreasing its volume in a significant way. More vapour can then enter the sterilization chamber, which penetrates even further inside the packages to be sterilized. Vapour eventually completely surrounds these and the pressure and temperature are established.

<sup>1</sup> Before loading the autoclave, the jacket is pressurized so that the interior of the chamber is hot to reduce the formation of condensed liquid at the beginning of the sterilization cycle.

<sup>2</sup> See the information on the sterilization cycles included further on.

<sup>3</sup> A typical cycle of a sterilizing autoclave, equipped with an exhaust system activated by an electro hydraulic pump is described.

- c) Once these conditions are attained, the countdown for completing the sterilization (depending on the type of objects or materials being processed) is initiated. The higher the temperature and pressure, the lesser the time required for sterilizing.
  - d) Once the programmed sterilization time has ended, post treatment process is initiated. This includes depressurization of the chamber normally done with the help of the exhaust and drying system using the supply of heat transferred from the jacket to the sterilization chamber. Upon decreasing the pressure, the required temperature for evaporating any liquid residue that may have formed on objects during depressurization is attained. A vacuum of 10 % of the atmospheric pressure is created and maintained steady for a period of time. When liquids are sterilized, no vacuum is created; rather, vapour extraction is controlled through a restrictive mechanism to prevent boiling inside the containers autoclaved.
  - e) Finally, controlled entry of air through valves with high efficiency filters will be allowed until the pressure in the sterilization chamber is equal to the atmospheric pressure. The sterilization cycle has ended.
7. Open the door of the autoclave.
  8. Unload the sterilized material.
  9. Close the door once the sterilized material is unloaded to conserve the heat in the sterilization chamber and facilitate the next sterilization cycle.
  10. Store the sterilized material appropriately.

**Note:** The sterilization cycles must be supervised and submitted to quality control procedures through the use of physical, chemical and biological type indicators for ensuring their effectiveness.

**Warning:** Not all objects can be sterilized with moist heat. Some require sterilization procedures at low temperature. Verify which procedure must be used according to the type of material to be sterilized.

### Sterilization cycles

The sterilization processes follow predefined cycles according to the type of load to be sterilized. There are different sterilization cycles for porous materials, surgical instruments, liquids or heat sensitive material. The main ones known as clinical sterilization cycles are carried out under the following conditions: 121 °C / 1.1 kg /cm<sup>2</sup> or 134 °C / 2.2 kg /cm<sup>2</sup>. Their main characteristics are featured in the table on the next page.

**Note:** The sterilization cycle times are adjusted to the altitude where the autoclave is located. Manufacturers supply compensation tables to be taken into account. In

general, the higher the altitude of the equipment's location, the longer the sterilization time will be.

### Quality Control

In order for a product to be considered sterilized, it is necessary to verify that all the stages of the sterilization process have been carried out correctly. To verify that these have been fulfilled, a series of tests have been developed to evaluate the characteristics of the process and its influence on the activity of microorganisms. Evaluations of the temperature, pressure, time, humidity and general equipment behaviour are carried out to certify that it complies with, and functions according to procedures that demonstrated its validity and reliability. There are also tests or indicators that allow the death of the microorganisms to be certified in order to guarantee the quality of the sterilization processes. Different categories of tests have been developed. Some are featured next:

1. **Sterilization process indicators.** These are designed for supervising the functioning of the autoclaves. They include instruments that control parameters like temperature, time and pressure (thermometers, manometers and chronometers) and register the development of the process. The registering systems of modern autoclaves (microprocessor) register all the parameters of the sterilization cycle and also halt the cycle in case some anomaly occurs. There is also the Bowie-Dick test in this category: it evaluates the efficiency of the exhaust pump using a test sheet which changes in colour uniformly if the process has been completed satisfactorily. If it is not the case, the colour of the sheet is uneven.
2. **Chemical indicators.** These are typical chemical tests changing colour or state when exposed to the different phases of the sterilization process. Chemical indicators allow the differentiation of articles submitted or exposed to a successful sterilization process from those that have not. Among the best known are the adhesive tapes or strips that go inside a component or on packages. The ISO N° 11140-1 standard describes categories of chemical indicators. One has to keep in mind that chemical indicators by themselves do not guarantee that the sterilization process complied with all the requirements: personnel who use these must receive precise training to allow them to determine if the result obtained is coherent with the evolution of the whole sterilization process.
3. **Biological indicators.** These are considered the best methods for controlling the quality of a sterilization process. They are made of live microorganisms which have a greater resistance to a determined sterilization process, or of chemical reagents which react in the presence of the specific proteins of this type of organism. In order to control the sterilization process by saturated vapour, (hydrogen peroxide) or formaldehyde, spores

Cycle no.	Materials	Temp. °C	Pressure kg/cm <sup>2</sup>	Typical graph <sup>1</sup>
1	<ul style="list-style-type: none"> <li>• Porous loads</li> <li>• Textiles</li> <li>• Wrapped instruments</li> <li>• Tubes</li> </ul>	135	2.2	
2	<ul style="list-style-type: none"> <li>• Open instruments</li> <li>• Utensils</li> <li>• Glassware</li> <li>• Open containers</li> </ul>	135	2.2	
3	<ul style="list-style-type: none"> <li>• Heat sensitive materials</li> <li>• Rubber</li> <li>• Plastic</li> </ul>	121	1.1	
4	<ul style="list-style-type: none"> <li>• Liquids in open or semi-closed containers.*</li> </ul>	121	1.1	<p>121°C, 20 min</p>
Convention	<p>A: Pre-treatment. Alternate cycles of injection / vacuum of vapour. Pre-treatment. (Processes 1, 2, 3).</p> <p>Process 4: Sterilization.</p> <p>C: Post-treatment (Process 5: vacuum and drying).</p> <p>D: Internal and external pressures completely mixed.</p> <p><b>Note:</b> The liquid process does not have vacuum after sterilization. The cooling is natural.</p>			

<sup>1</sup> The graphs included correspond to an autoclave with an emptying pump, Getinge brand GE-660 autoclave.  
 (\*) Times depend on the volume of the load. There is no vacuum during cooling.

of *Bacillus stearothermophilus* are generally used. To control sterilization by dry heat (a process that drying ovens perform) and by ethylene oxide, spores of the *Niger* variety of *Bacillus subtilis* are used. The spore indicator is placed in the sterilizing load. After the process, it is incubated, analyzed and it is determined if the cycle meets with the sterilization requirements. Generally a change of colour is observed. These tests are standardized and manufacturers indicate how to use them and interpret the results. Biological indicators by themselves do not guarantee that the sterilization cycle complies with all the requirements. The only way to do this is by controlling all the sterilization cycle's parameters.

**Frequency of the quality control processes**

A table summarizing the suggested frequency with regard to the use of quality control indicators in the sterilization processes is shown next.

Type of indicator	Frequency of use
Process	In each sterilization cycle.
Chemical	In each package.
Biological	Weekly, in all the sterilization equipment; in the packets that contain implants.

**INSTALLATION REQUIREMENTS**

To be able to function, autoclaves require the following services:

1. A well ventilated area for removing heat and humidity generated while in operation. It also requires free space around the back and sides, to accommodate technical

servicing. This space should be at least 0.8 m. Depending on the design of the autoclave, complementary infrastructure must be anticipated so that it can operate satisfactorily. The diagram in Figure 33 explains the space required around the autoclave. The temperature in the immediate vicinity of the equipment may increase to more than 70 °C when it is in operation. The floor should be well levelled and constructed with materials resistant to humidity and heat.

2. An electrical outlet in proportion to the equipment's consumption. If the autoclave is autonomous, meaning that it has its own vapour generator, the electrical connection must be studied in detail as the required power could be significantly higher. Typical power demands are 21, 38, 48 kW and higher, for the vapour generator to function. The connection must be equipped with required safety and protection elements. The typical voltages required for autoclaves are 220 V, 60 Hz, or 380 V, 60 Hz triphase.
3. Water connection proportional to the equipment's consumption in volume and pressure: the larger the equipment, the greater the consumption. The water which the autoclave consumes must have received required treatments for eliminating solids in suspension as these may negatively affect the functioning of the electrovalves as well as that of the electro hydraulic devices.
4. Some sterilizers require compressed air, as their controls are managed by pneumatic pressure. In general, the required pressure varies from  $5 \times 10^5$  to  $9.9 \times 10^5$  Pa. The following diagram shows the minimum installation requirements (cut-off valve, filter and manometer).
5. A drainage system designed for collecting hot water.
6. A vapour connection. If the autoclave does not have its own vapour generator, it must be fed from the institution's vapour generating system (machine room, boiler). The supply installation must meet the necessary

**Figure 33.** Space required for autoclave

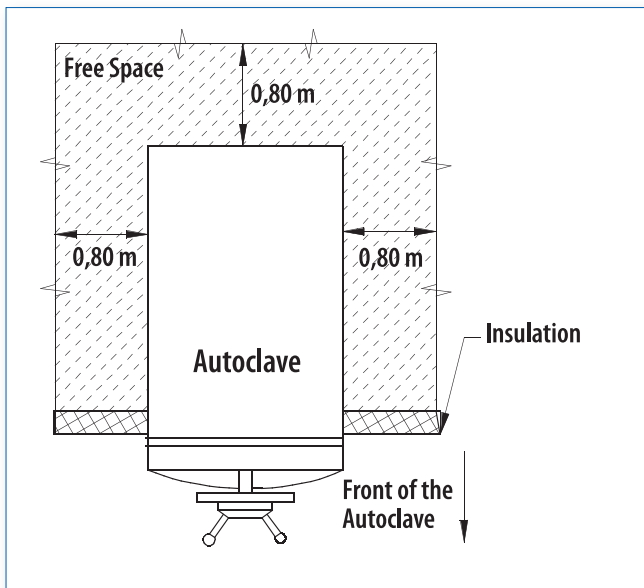

**Figure 34.** Compressed air connection

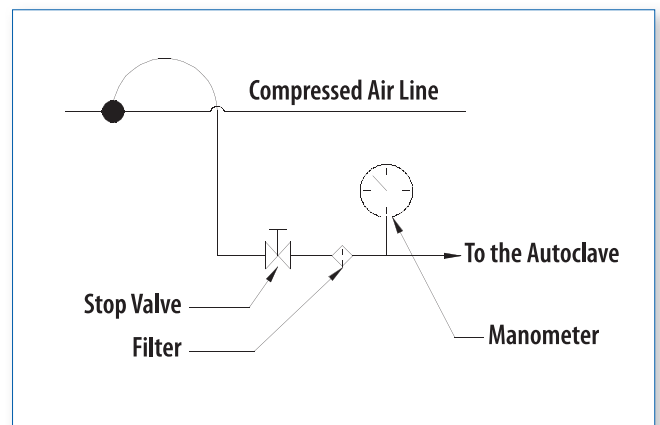

requirements: a cut-off valve, filter, manometer as well as an appropriate installation for collecting the condensed liquid with a filter and vapour trap, as indicated in the

Figure 35. Vapour connection

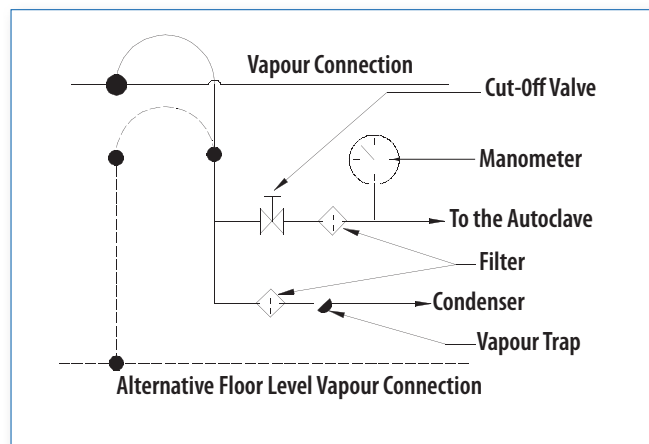

Figure 35.

- The autoclave must be operated exclusively by personnel specially trained and qualified in these types of processes.

### ROUTINE MAINTENANCE

The autoclave is equipment which demands supervision and continuous preventive maintenance due to its multiple components and systems. Maintenance is focused on the basic routines that can be performed by the operators. In order to carry out detailed maintenance, the instructions described in the manufacturer's service manuals must be followed.

#### Daily verifications

Before initiating the sterilization processes, the following verifications will have to be carried out:

- Place a new form on the registration device in order to document the development of the sterilization cycle.
- Ensure that the cycle-recording pen or that the printing module of the autoclave has ink and recording paper.
- Ensure that the cold water, compressed air and vapour supply valves are open.
- Activate the switch that triggers the autoclave's jacket heating. Upon activating this control, vapour is allowed to enter the sterilization chamber's jacket. When vapour enters the sterilization chamber, the heating process begins. To avoid heat loss, keep the autoclave's door closed until it is time to add the load for sterilization.
- Verify that the pressure from the vapour supply line is at least 2.5 bar.
- Test the condition of manometers and thermometers.
- Ensure that there are no vapour leaks in any of the systems functioning in the autoclave.
- Clean the front of the autoclave, controls, indicators and

handles with a damp cloth.

#### Weekly maintenance

##### **Responsible: The equipment operator**

- Clean the sterilization chamber drainage filter. Remove any residue retained inside.
- Clean the inside of the sterilization chamber using cleaning products that do not contain chlorine. Clean the guides used for placing the baskets as well.
- Clean with an acidified solution, if solutions with chlorine are being sterilized. The chlorine causes corrosion even on stainless steel implants. Next, wash with plenty of water.
- Clean the external rust-proof surfaces with a mild detergent. A solvent like ethylene chloride can be used, avoiding touching any surface with painted coverings, markings or plastic coverings.
- In autoclaves with manually activated doors, verify that these mechanisms are well adjusted and that their operation is smooth.
- Drain the vapour generator (if the equipment has one). To do this, open a valve located on the lower part of the generator which allows its contents to be drained. Generally this is done at the end of weekly activities. Follow the manufacturer's recommendations.
- Never use steel wool for cleaning the inside of the sterilization chamber.
- Check adequate functioning using a biological or chemical indicator. To check the temperature, use chemical test strips checking time and temperature of exposure sold for this purpose.

#### Quarterly maintenance

##### **Responsible: The autoclave technician**

- Check that the manometers function as expected.
- Activate the safety valves manually to verify that they are operating well. Use a large screwdriver to move the activation lever normally located in the upper part of the valve. Make sure that the face and body of the operator are not in the vapour's path. Once the valve is activated, ensure that there are no vapour leaks. If there are any leaks, the valve must be activated again until it is well sealed.

**Warning:** If vapour leaks are not eliminated, this will deteriorate the seal rapidly and the whole safety valve system will have to be replaced.

- Lubricate the door's gasket. Use the lubricant and the procedure recommended by the equipment's manufacturer. Some manufacturers recommend the following procedure:
  - Remove the gasket. To do this, it is necessary to dismount from the groove, loosening the retention mechanisms (screws and plates).

- b) Clean the gasket and the groove with alcohol so that there is no foreign material to affect the seal. The surface of the gasket must stay smooth and clean.
  - c) Apply the lubricant recommended by the manufacturer to the body of the gasket until it is completely protected. Many autoclave manufacturers use graphite lubricant resistant to high temperatures.
  - d) Reinstall the gasket. In rectangular chamber autoclaves, this is normally installed placing the gasket in the middle of one of the assembly groove's sides and adjusting the remaining portion towards the sides, until it is well adjusted inside the groove. The same procedure is repeated for each remaining side. In round chamber autoclaves, the gasket assembly begins on the upper part and is adjusted progressively into the groove without pulling it, until the whole gasket is installed. Next, assembly elements are adjusted.
4. Verify that the seals of the safety valves are in good condition.
  5. Clean the points of the registration pen system with water or alcohol and restore the ink levels. Generally, the pressure is registered with red ink and the temperature with green.
  6. Clean the inside of the vapour generator (for equipment with this accessory). For the vapour generator, the cleaning procedure involves carrying out the following activities:
    - a) Disconnect the electrical supply to the equipment.
    - b) Discharge the vapour pressure and wait for the equipment to reach room temperature.

- c) Remove the front cover of the generator.
- d) Disconnect the electrical terminals of the heating resistors (immersion).
- e) Remove the screws that secure the front plate where the heating resistances are installed and dismount the front plate.
- f) Check the gasket and substitute it if necessary.
- g) Remove dirt accumulated on the surface of the heating resistors. Use products recommended<sup>1</sup>.
- h) Re-assemble in the reverse order.

Figure 36 shows the vapour generator and its components.

**Annual maintenance**

**Responsible: The autoclave technician**

1. Clean all the filters.
2. Test and adjust the water level of feed tank so that it is within 20 mm of the maximum level.
3. Verify and adjust the tension of diaphragm valves' springs.
4. Dismount, clean and adjust the safety valves.
5. Change the air filter.
6. Conduct a general sterilization process testing in detail the pressure, temperature, required times for completing each phase of the cycle, state of the process' signal lamps and functioning of the registration system. Verify that it is functioning within tolerances defined by the manufacturer.
7. Perform the quarterly routines.

<sup>1</sup> Incrustations are seen when the water used by the vapour generator has not received adequate treatment.

**Figure 36. Vapour generator**

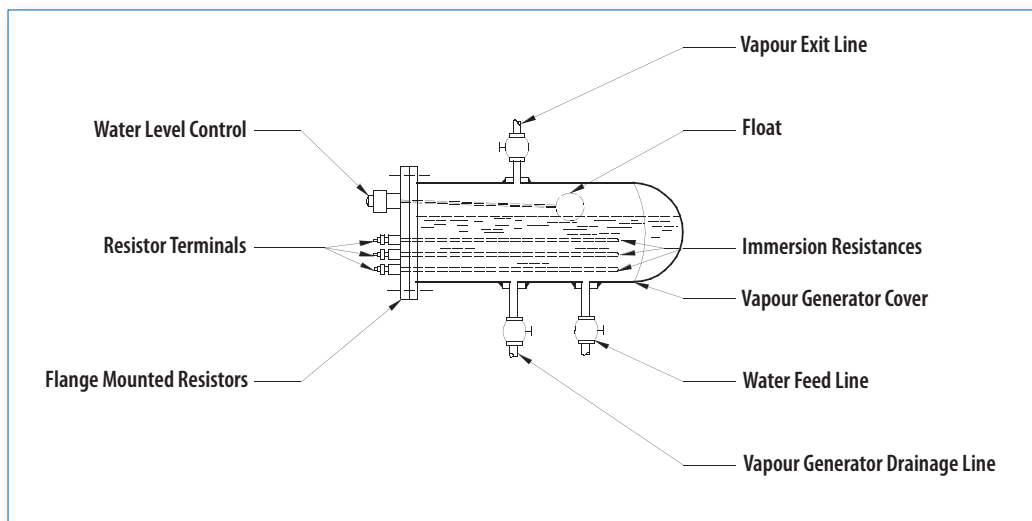

## MAINTENANCE OF SPECIALIZED COMPONENTS

Included next are some specialized routines requiring a service technician and applicable to equipment components. Given that autoclaves have multiple designs, routines stipulated here are only applicable to certain equipment models.

### Maintenance of solenoid valves

1. Verify the sound made by the bobbins or solenoids (*humming*). Excessive noise is a warning of overheating due to abnormally high electric currents through the solenoid. Current alternates rise when the impedance [Z] of the circuit decreases. This occurs when the solenoid is not adequately surrounded by a closed iron cover. An air gap in the magnetic circuit can be caused by dirt which prevents the protective cover from reaching its final position when the solenoid is energized. Carefully clean the housing of the bobbin and its nucleus so that the piston's movement is not impeded by filth.
2. Replace the O-rings between the solenoid and the body of the valve once these have been disassembled.
3. Before any disassembly, verify how the solenoid valve is installed. Some possess clear installation indications but others lack such information.
4. When dismantling a servo-assisted solenoid valve, control the position of the orifices that put it in contact with the work environment, so as to be able to re-assemble the valve.

## Cleaning of the vapour filter

**Warning:** Before disassembling the vapour filter, dissipate the vapour pressure in the system.

1. Lift the cover.
2. Remove the mesh.
3. Clean carefully.
4. Reinstall the mesh.
5. Replace the cover.

Here are some of the most common problems. Given the diversity of brands, models and available technology, it is advisable that users follow instructions from the user manual for the autoclave used.

TROUBLESHOOTING TABLE			
PROBLEM	PROBABLE CAUSE	SOLUTION	
The sterilization indicator did not indicate the successful end of the sterilization cycle.	The sterilization chamber is incorrectly loaded or over-loaded.	Check the load distribution and the load quantity. Adjust according to the manufacturer's recommendations.	
	The vapour trap is defective.	Check the vapour trap. Repair or substitute it.	
	The sterilization time is insufficient.	Check the sterilization time. Adjust to the cycle type.	
	The autoclave does not reach the temperature and sterilization pressure selected.		Check the temperature selection. Check the vapour pressure corresponding to the selected cycle.
			Check for possible vapour leaks in the door (gasket) or in the passage control devices.
	There is insufficient vapour penetration.	Reduce the quantity of packets to be sterilized; this allows a better vapour flow.	
	The pre-treatment is inadequate. Too much air has remained inside the chamber.	Seek the assistance of a specialized service technician to check the exhaust system.	
The biological indicator is inappropriate for the cycle conducted.	Check the user specifications of the biological indicator. Repeat the sterilization cycle.		
The sterilization cycle is interrupted without any apparent reason.	Inadequate vapour, water or air pressure. As a result, the regulation and servo-assisted control devices are not activated.	Check vapour, water and air feed pressures. Adjust the regulation systems.	
The sterilized material comes out damp.	The vapour trap is defective.	Check/clean the vapour trap. Substitute the trap.	
	The sterilization chamber drainage is blocked.	Check the drainage system. Clean.	
	The autoclave is overloaded.	Reduce the load quantity in the chamber. Repeat the sterilization cycle.	
	The autoclave is not levelled.	Level the autoclave.	
The biological indicator is positive.	The biological indicator was incorrectly selected.	Use a biological indicator of another lot or manufacturer. Carefully register the parameters.	
Vapour pressure too low.	The door's gasket is defective.	Check the gasket; replace it.	
	The internal vapour leaks into another autoclave component.	Check the traps, electrovalves etc.	
There is excessive vapour pressure.	The autoclave is overloaded with textile material.	Reduce the autoclave's load.	
	Autoclave is not calibrated.	Calibrate the autoclave.	



## BASIC DEFINITIONS

**Asepsis.** A set of procedures necessary to eliminate microorganisms.

**Atmosphere.** An old unit of pressure equivalent to 101 325 Pa (Pascals) or to 14.69 pounds per square inch.

**Bar.** A unit of pressure equivalent to  $10^5$  Pa (Pascals).

**Cleaning.** Mechanical removal of all foreign material located on the surface of inanimate objects; in general, it implies the use of clean water combined with a detergent. It is a basic procedure performed before submitting the objects to their respective sterilization processes. Cleaning can be done manually or by using automatic methods. It must be understood that it is not a procedure destroying microorganisms, but only decreasing their quantity.

**Decontamination.** A procedure to decrease the quantity of microorganisms of an object or substance so that its use or/and manipulation is safe. For example, objects used in patient care procedures in possible contact with fluids, bodily substances or organic materials require decontamination or even sterilization (see definition below).

**Disinfection.** A process that uses physical or chemical means to destroy any form of life in a vegetative state from inanimate objects (excluding spores).

**Inspection.** A visual evaluation of washed articles, with the purpose of finding defects or dirt that may interfere with the sterilization processes. It is a process of great importance which may be done using a magnifying glass to discern minute details.

**Jacket.** Enclosed space around the sterilization chamber through which vapour circulates. Its function is to transfer heat to the sterilization chamber in the pre-treatment stages (air removal) and post treatment (drying of the sterilized material).

**Moist heat.** A sterilization method that eliminates microorganisms by denaturation of the proteins which is accelerated by the presence of water vapour (steam).

**Pascal (Pa).** A unit of pressure from the International system, which corresponds to the force of a Newton (N) that acts on a (1) square meter:

$$\text{Pa} = \frac{1\text{N}}{\text{m}^2}$$

**Quality.** Thermodynamic property identified in general with the letter [X] and defined as the relationship existing between the vapour mass and the total mass of the substance under saturated conditions.

**Servo-assisted valves.** Solenoid-type valves that depend on the surrounding pressure to close or open. In general, these have membranes with small openings through which the working medium is supplied.

**Solenoid valves.** Electromagnetic control devices used in multiple applications also known as electrovalves. The position of a piston is controlled by a bobbin which is energized or at rest. The piston permits or impedes the passage of a fluid inside of a determined circuit. They are used in hydraulic, pneumatic, vapour and vacuum systems. Manufacturers have developed a great number of designs for specialized applications.

**Sterilization.** A set of actions by means of which all forms of life are destroyed (including spores) on inanimate objects using physical, chemical and gaseous procedures.

**Sterilization chamber.** The area where objects requiring sterilization are placed. When the sterilization process is being carried out, the chamber is filled with pressurized vapour, reaching temperatures directly related to the selected pressures. During the sterilization cycle, it is sealed by a door by a safeguarding system which can only be opened once the sterilization process has been completed and the internal pressure has reached that of the atmosphere.

**Sterilization indicator.** A chemical or biological indicator that allows checking if an object or material has been submitted to a sterilization process successfully. The most commonly known are the thermosensitive tape (it changes colour when the determined temperature conditions are reached) and *B. stearothermophilus* spores.

**Vapour trap.** A device designed to restrict the passage of vapour and allow the passage of condensed liquid.

# Chapter 13

## Drying Oven

<b>GMDN Code</b>	21086	21087
<b>ECRI Code</b>	21-086	21-087
<b>Denomination</b>	Oven, laboratory	Oven, laboratory, forced-air

The drying oven is used in the laboratory for drying and sterilizing glass and metal containers. Manufacturers have developed several types of drying oven for that purpose: some operate by natural convection or by forced convection, others by gravity convection. In general, the ovens operate between room temperature and 350 °C. They are also known as *hot air oven*, or *poupinel* or *pupinel*.

### PHOTOGRAPH OF DRYING OVEN



Photo courtesy of Cole-Parmer Instrument Co.

### PURPOSE OF THE OVEN

The drying oven is used for sterilizing or drying glassware and metal materials used for examinations or tests performed in the laboratory. Dry heat sterilization of clean material is conducted at 180 °C for two hours in the oven. Upon being heated by high temperature dry air, humidity is evaporated from glassware and thus the possibility of any remaining biological activity is eliminated.

### OPERATING PRINCIPLES

Generally, drying ovens have an internal and an external chamber. The internal chamber is made of aluminium or stainless steel material with very good heat transference properties. It has a set of shelves made of stainless steel grids so that air circulates freely around objects requiring drying or dry heat sterilization. It is isolated from the external chamber by insulating material which maintains high temperature conditions internally and delays the transference of heat to the exterior. The external chamber is made of steel laminate, covered with a protective film of electrostatic paint. Heat is generated through sets of electrical resistors transferring this thermal energy to the chamber. These resistors are located in the lower part of the oven and heat is transferred and distributed by natural or forced convection (in oven with internal ventilators).

The power (energy by a unit of time) dissipated by an electrical resistor can be calculated by means of the following equation:

$$P = I^2 R$$

Where:

I = Intensity of the electric current in amps [A]

R = electrical resistance in ohms [ $\Omega$ ]

Given that the energy is neither created nor destroyed but transformed, it is possible to calculate the thermal energy equivalent to the resistive elements. In the case of a resistive wire, the quantity of heat [q] dissipated can be calculated by the following equation<sup>1</sup>:

$$I^2 R = \dot{q} \pi r_0^2 L$$

Where:

R = resistance of resistive wire

I = intensity of the electrical current

$r_0$  = outer radius of the wire

L = length of the resistance wire

$\dot{q}$  = is the heat generated per unit volume

Resistance [R] can be calculated by the following equation:

$$R = \rho \frac{L}{A}$$

Where:

$\rho$  = resistivity of the resistor's material

A = surface of the resistance wire

The oven has a metallic door with its own thermal insulation equipped with a similarly insulated handle to prevent burns on hands. The door is installed on the front part of the oven by a set of hinges which allow it to open at a 180° angle.

The modern oven is controlled by a module with a microprocessor. It allows selection of the equipment's operation parameters and its alarms; and the programming of cycles or thermal processes through which are controlled, not only the temperatures but also the way in which they need to vary in time through phases of heating/cooling (natural) or through stable temperatures maintained within certain time intervals. Ovens operate normally from room temperature up to 350 °C. Some models have limited ranges of operation. Older ovens simply have a set of resistors, whose operation is controlled by a thermostat.

The following table features the temperature/time relationship required for dry heat sterilization in drying ovens.

Table of temperature/sterilization time by dry heat

Temperature °C	Time in minutes <sup>2</sup>
180	30
170	60
160	120
150	150
140	180
121	360

## INSTALLATION REQUIREMENTS

In order to be used, the drying oven requires the following:

1. A large, strong, levelled work table.
2. Free space of at least 5 cm around the oven and enough space to place the material to be processed.
3. An electrical outlet with a ground pole of appropriate size for supplying electrical power to the oven. It must be in good condition and comply with the national or international electrical standards used in the laboratory and must not be more than 1 m away from the equipment. The typical voltage used is 110 V or 220 V/60 Hz.
4. Verifying that the electrical circuit has the necessary protection devices for guaranteeing an adequate electrical feed.

## OVEN OPERATION

A series of precautions must be taken into account for the correct operation of the oven. Among the most important are the following:

1. Do not use flammable or explosive materials in the oven.
2. Avoid spills of acid solutions or corrosive vapours inside the oven to prevent corrosion of the surfaces and interior shelves.
3. Use personal protection elements (insulated gloves, safety glasses and tongs for placing or removing substances or materials inside the drying oven).

### Operation routine

In general, the following procedure is performed:

1. Activate the main switch, pressing the button usually identified by the symbol [I].
2. Press the key identified as *Program*.

<sup>1</sup> This example of heat transference equation is for a wire-type resistor of circular shape. For other shapes, different equations must be used.

<sup>2</sup> Time is counted from the moment that the corresponding temperature is reached.

3. Select the operational temperature by pressing the key marked by the sign (+) until the selected temperature appears on the screen. The oven will start the heating process until reaching the selected temperature.
4. For programmable ovens, instructions must be followed as defined by the manufacturer for setting additional parameters such as time, types of warming and alarms.

**OVEN CONTROLS**

A diagram of controls regulating modern drying ovens is shown in Figure 37. It is possible to identify the following elements:

1. The main switch.
2. Screens for controlling the current and selected temperatures.
3. The parameter selection button (menu).
4. The button for programming operation cycles.
5. Buttons for increasing and decreasing the temperatures.

Each manufacturer supplies detailed instructions to operate these controls. In general, they are located on the lower part of the oven and are cooled by a ventilator which circulates ambient air inside the assembly space where other electronic components are installed.

**Electric circuit**

Figure 38 shows the basic electrical circuit of the drying oven. The following elements are outlined:

1. **Main switch.** It energizes or turns off the oven.
2. **Control.** It controls the oven’s functions (temperature, time, type of heating and cooling, selected operation modes such as preheating, sterilization, dehydration, preparation, drying and even baking).
3. **Resistors.** Heating elements transforming electrical energy into thermal energy.
4. **Indicator systems.** Devices complementing the general control. These indicate if the oven is ON and in operation.

**Figure 37. Electronic control of the oven**

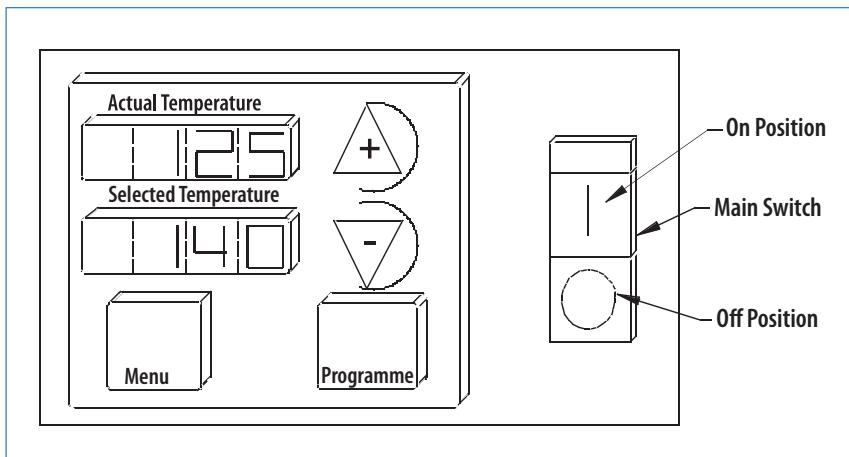

**Figure 38. Electric circuit of the oven**

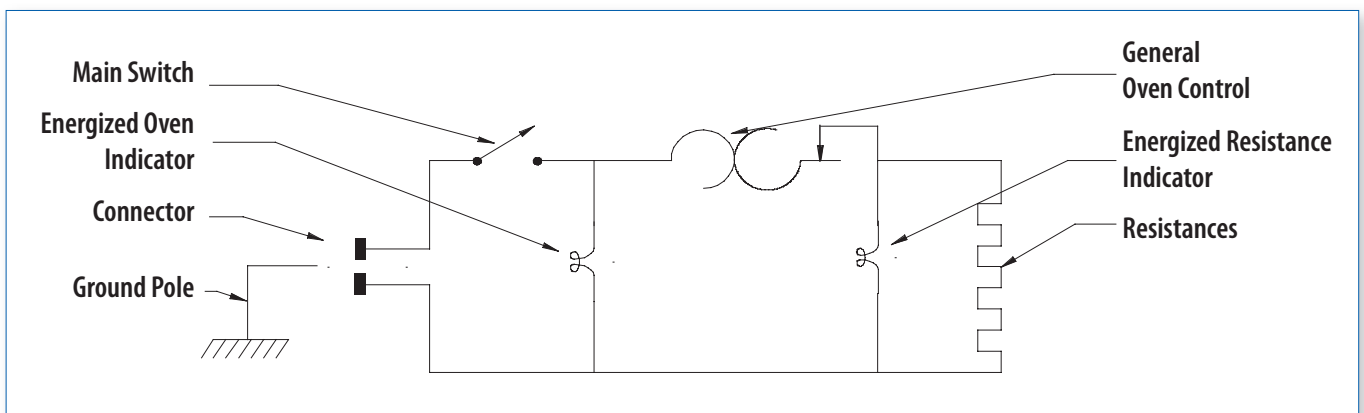

## QUALITY CONTROL

Quality control of drying ovens is slightly demanding since sterilization by dry heat has temperature and time as critical parameters. Generally, spores of *Bacillus subtilis* (Niger variety) are used as biological indicators. These must be incubated for several hours after the sterilization process. The initial spore load of the biological indicator ranges between  $5 \times 10^5$  and  $1 \times 10^6$ . The effectiveness of the cycle depends on the diffusion of heat, its amount available and the amount lost. Its microbicidal action is affected by the presence of organic material or filth on the article. Sterilization by dry heat must be limited to materials which cannot be sterilized in autoclaves.

## ROUTINE MAINTENANCE

The maintenance required by a drying oven is simple and no complex routine maintenance is necessary. General maintenance routines to carry as necessary are described next. The procedures vary depending on the type of oven and designs from different manufacturers.

**Warning:** Before carrying out any maintenance routine on the oven, verify that it is at room temperature and disconnected from the electrical feed outlet.

### Access to electronic components

#### Frequency: Whenever necessary

The oven's electronic components are usually located in its lower part. In order to be able to check them, proceed as follows:

1. Disconnect the oven from the electrical feed outlet.
2. Move the oven forward until the front part of the base is aligned with the edge of the working space.
3. Place two wedges of approximately 3 cm in thickness below each front support. This will elevate the front part of the oven and facilitate the inspection of electronic elements once the lower cover is removed.
4. Remove the screws securing the lower cover and lift it. Next, check the electronic control components. In general, the following elements are located in this compartment.
  - a) The programmable control panel
  - b) A safety release
  - c) The main switch and circuit breaker (combined)
5. Replace the cover once checking has been completed.

### Changing of the heating resistors

#### Frequency: Whenever necessary

The procedure explained next must be performed by personnel with a good knowledge of electricity.

1. Disconnect the oven from the electrical feed outlet.
2. Remove the thermometer from the upper part of the chamber.
3. Open the door and remove the shelves.

4. Disconnect the thermometer's probe.
5. Remove the screws that secure the lower panel.
6. Remove the lower panel.
7. Remove the screws that secure the resistor's electrical feed cables and disconnect the terminals fastening these to the resistors.
8. Remove the screws that secure the resistors as well as the external resistors.
9. Install new resistors with the same characteristics as the originals.
10. Reinstall the parts and reconnect the electrical components.

### Changing the cooling ventilator

#### Frequency: Whenever necessary

To change the cooling ventilator (generally located in the lower part), these procedures must be followed:

1. Proceed as explained for opening the electronic compartment.
2. Disconnect the ventilator's electrical feed terminals.
3. Undo the screws that secure the ventilator.
4. Install a ventilator with the same specifications as the original; connect the wires feeding the ventilator to the terminals.
5. Replace the protective cover.

### Changing of the door gasket

#### Frequency: Whenever necessary

The door's gasket is usually made of silicone.

1. Turn off the oven and open the door.
2. Loosen the safety devices that keep the gasket in place.
3. Remove the gasket using a screwdriver for disengaging it from the retention guide. Avoid using excessive force which can distort the housing.
4. Install the replacement gasket starting from the upper part. Next, move the rest of the gasket towards the sides, securing it with the assembly elements which fasten it to the door. Finish the procedures on the lower part of the door in the same fashion.

### Changing of the thermocouple

#### Frequency: Whenever necessary

1. Open the electronic control compartment.
2. Remove the thermocouple's connecting cables from their connection points on the control card.
3. Loosen the thermocouple assembly from the upper part of the oven. Move it towards the front part until a free length of at least 15 cm of connector cable is left exposed.
4. Cut the cable from the thermocouple to remove its wrapping.
5. Secure the cut ends of the defective thermocouple with the cables from the replacement. Use tape to prevent these from becoming loose.

6. Gently pull the defective thermocouple outside of the electronic compartment while keeping the electric wiring attached to use as a guide during its replacement
7. Disconnect the wires of the old thermocouple and place those of the new thermocouple into their respective connection terminals. Check that the original polarity is maintained.
8. Reassemble the protective cover.

**Changing of the door hinges**

**Frequency: Whenever necessary**

To change the door hinges, proceed as explained next:

1. Open the door and lift it from the hinges.
2. Remove the assembly screws of the defective hinges.
3. Remove the defective hinge(s).
4. Put the new hinge(s) in place and tighten with the assembly screws.
5. Reinstall the door.

TROUBLESHOOTING TABLE		
PROBLEM	PROBABLE CAUSE	SOLUTION
There is no power to the oven.	The oven is not connected.	Connect the oven to the electrical outlet.
	The main switch is off.	Activate the start switch.
	The circuit breaker is defective.	Change the circuit breaker.
	The control card is defective.	Substitute the control card.
	The connector cable is defective.	Check/repair connector cables.
Erratic elevated temperature.	The thermocouple is defective.	Substitute the thermocouple.
	The control is defective.	Substitute the control.
The oven shows heating errors.	A temperature lower than that selected.	Change the temperature selection. Wait until it reaches the selected temperature.
	The thermocouple is defective.	Substitute the thermocouple.
	The heating resistor is defective.	Substitute the heating resistor.
	The relay is defective.	Substitute the relay.
	The control is defective.	Replace the control.
The screen displays the message "open".	The thermocouple circuit is open.	Verify the thermocouple connection or substitute the thermocouple.



## BASIC DEFINITIONS

**Circuit breaker.** An electrical control device which allows a piece of equipment or a device to be ON or OFF. It is also called a switch.

**Electric Thermocouple.** A device used for accurate measurement of temperature. It consists of wirings of two different metals joined together at one end, producing a small voltage proportional to the difference in temperature between the two ends. This phenomenon is known as the “Seebeck effect” in honour of its discoverer, the German physician Thomas Seebeck.

**Heat.** A form of energy transferred from one system at a given temperature to another at a lower temperature by means of the difference in temperature between the two. When a system of great mass [M] is put in contact with another of small mass [m] at a different temperature, the resulting temperature is close to the initial one of the greater mass system. It is said, then, that a quantity of heat  $\Delta Q$  has been transferred from the system of higher temperature to that of lower temperature. The quantity of heat  $\Delta Q$  is proportional to the change in temperature  $\Delta T$ . The proportion constant [C] or heat capacity of the system, allows the following relationship to be established:  $\Delta Q = C\Delta T$ , which infers that one of the consequences of the change in temperature in a system is heat transference.

**Resistance.** Opposition that a material or electrical circuit imposes to the flow of electric current. It is the property of a circuit that transforms electrical energy into heat as it opposes the flow of current. The resistance [R], of a body of uniform section such as a wire, is directly proportional to the length [l] and inversely proportional to the sectional area [a]. The resistance is calculated by the following equation:

$$R = k \times \frac{l}{a}$$

Where:

k = constant that depends on the units employed

l = Length of the conductor

a = sectional area of the conductor

The ohm ( $\Omega$ ) is the common unit of electrical resistance; one ohm is equal to one volt per ampere.

**Thermostat.** A device which regulates the temperature of a system. It usually operates by expansion of one of its components which mechanically activates another element, for example a switch which controls a particular function.

# Chapter 14



## Incubator

<b>GMDN Code</b>	<b>35482</b>	<b>35483</b>
<b>ECRI Code</b>	<b>15-151</b>	<b>15-152</b>
<b>Denomination</b>	<b>Aerobic incubator</b>	<b>Anaerobic incubator</b>

The word incubator comes from the Latin word *incubare* which means to *brood*. The incubator is designed as a chamber of controlled temperature, atmosphere and humidity for the purpose of maintaining live organisms in an environment suitable for their growth. Among its most common uses are incubation of bacteriological, viral, microbiological and cellular cultures; determination of the biochemical demand for oxygen (BOD) and biological storage. Incubators vary in complexity and design. Some only control temperature while others control the atmospheric composition as well. Some have the capacity to achieve temperature conditions below room temperature with refrigeration systems. Depending on the design and specifications, incubators control

temperatures from -10 °C and go up to 75 °C or slightly more. Some incubators have CO<sub>2</sub> injection for achieving special atmospheric conditions at which the growth of diverse species of organisms and cells is favoured.

### OPERATING PRINCIPLES

The incubator uses diverse means of heat transference and environmental control to achieve conditions for specialized laboratory procedures. In general, these have a system of electrical resistors controlled by thermostats or microprocessors. As for the heat transference systems, the incubators use conduction and natural or forced convection.

### PHOTOGRAPH OF INCUBATOR

#### Standard incubator



Photo courtesy of Cole-Parmer Instrument Co.

#### Thermal conduction

In incubators functioning by thermal conduction, a set of electrical resistors transfers heat directly to the wall of the chamber where samples are incubated. The resistors constitute a region of high temperature, while the chamber is one of lower temperature. Transference of thermal energy always occurs from the region of higher temperature towards the region of lower temperature according to the following basic equation by Fourier:

$$q = -kA \frac{\partial T}{\partial x}$$

Where:

q = quantity of heat transferred by conduction

k = thermal conductivity of the material

a = area of heat transference

$\partial T$  = temperature gradient in the direction of the heat flow

The minus sign (-) is introduced into the equation to fulfil the second law of thermodynamics.





### Thermal convection

In incubators with thermal convection, heat generated by the system of resistors is transferred through air circulating in the incubation chamber, transferring it to the samples. The efficiency of this process depends on air flow patterns. In general, air enters from the bottom of the incubator and is heated in a compartment from which it flows into the incubation chamber according to uniform patterns. It finally exits through a pipe located in the upper part of the incubator.

The basic equation which explains convection is<sup>1</sup>:

$$q = hA(T_w - T_\theta)$$

Where:

$q$  = Quantity of heat transferred by convection

$h$  = Convection coefficient for heat transfer

$A$  = Area by which heat is transferred

$T_w$  = Temperature on the surface of the resistor

$T_\theta$  = Temperature of the fluid (air)

Some incubators also have ventilators to circulate air by forced convection. In the following diagram, three designs used for incubators are shown in Figure 39: thermal conduction, natural convection and forced convection.

When a temperature lower than room temperature [ $T_a$ ] is needed in the incubation chamber, it is necessary to have a refrigeration system. This allows heat to be extracted to keep the incubation chamber cooler. The refrigeration system is operated by the incubator's temperature control system. Water in liquid state has a great capacity of absorption and

thermal retention. Some manufacturers have incorporated water chambers surrounding the incubation chamber into their designs. This is particularly useful for guaranteeing very stable temperature conditions inside the incubation chamber.

Incubators designed to inject and maintain concentrations of gases such as carbon dioxide ( $CO_2$ ) in the incubation chamber between 3 % and 5 % are available.

The incubator temperature control system is based on the use of thermostats (bi-metallic or fluid expansion); thermocouples, thermistors or diverse semi-conductor elements. These use electronic circuits which control, through microprocessors, the temperature as well as the incubator's functions. Each manufacturer has developed its own design. Actual or programmed incubator temperature and other information are shown on light emitting diodes (LED) displays.

In order for an incubator's temperature to be properly regulated, there must be a difference of at least 5 °C between the temperature of the chamber [ $T_c$ ] and room temperature [ $T_a$ ]. If the chamber's temperature [ $T_c$ ] must be lower than room temperature [ $T_a$ ], a refrigeration system is required. In consequence, the acquisition of incubators depends on the type of procedures carried out in the laboratory. Technical specifications must be studied and carefully defined in order for the acquisition to meet the actual needs of each laboratory.

<sup>1</sup> Heat transference by convection equation, developed by Isaac Newton (law of cooling).

Figure 39. Heat transfer systems used in incubators

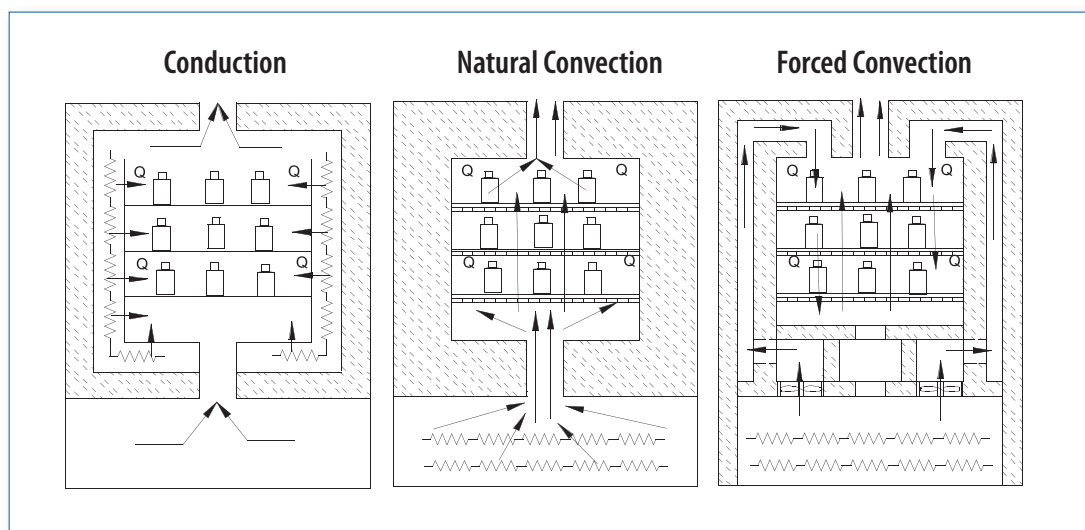

### INCUBATOR CONTROLS

The diagram shown in Figure 40 illustrates the type of controls normally found in recent models of incubators.

1. A main switch for turning the equipment on or off. Some manufacturers include a protection *breaker*. The switch has two positions: ON position [I], the incubator is energized. In position [O], the incubator is turned OFF.
2. A screen displaying the selected parameters. For example: selected temperature, alarm temperature (maximum and minimum).
3. Two control buttons are normally identified as *Menu* and *Selection* or *Set*. These allow the incubator to be programmed and to determine the alarm thresholds.
4. Two selection buttons for temperature adjustment. The selection buttons are used in combination with control buttons.
5. A set of LED displays signalling the operational state. If the heating system is in operation, the LED reads as "Heat". If the incubator is being programmed, the LED display reads as "Program".
6. The selection and control buttons are located on the control panel.

Each manufacturer uses controls suitable for the incubator's design: in general, incubators have the controls mentioned above. Instructions are found in user manuals provided by the manufacturers.

In general, the parameter desired is selected by using the *Menu* button. Using the selection button(s), parameters are adjusted until reaching the desired point. The selection is then confirmed by using the *Selection* or *Set* button.

### INSTALLATION REQUIREMENTS

Incubators require the following conditions for their functioning:

1. An electrical connection complying with the electrical standards used in the country. The electrical outlet feeding the incubator must not be more than 1.5 m away from the incubator. The electrical connection must supply a voltage of 120 V, 60 Hz or 220-240 V, 50/60 Hz and have its own ground connection.
2. Free space on the sides and back of the equipment to allow a passage for cables and ventilation required for the incubator's normal functioning. This space is estimated between 5 and 10 cm.
3. An area in the laboratory where the temperature variation is minimal.
4. A firm, levelled table or counter, capable of supporting the incubator's weight. The weight of an incubator with three shelves is between 60 and 80 kg.
5. Pressure regulators, hoses and connections for incubators using carbon dioxide (CO<sub>2</sub>), as well as anchors permitting the high pressure CO<sub>2</sub> tank to be secured.

### ROUTINE MAINTENANCE AND USE OF THE INCUBATOR

The general operation and routine maintenance for incubators are featured next. The specific procedures must be followed according to the recommendation of each manufacturer.

#### Recommendations for operation

1. Do not use an incubator in the presence of flammable or combustible materials as components inside of this equipment could act as ignition sources during operation.

Figure 40. Incubator controls

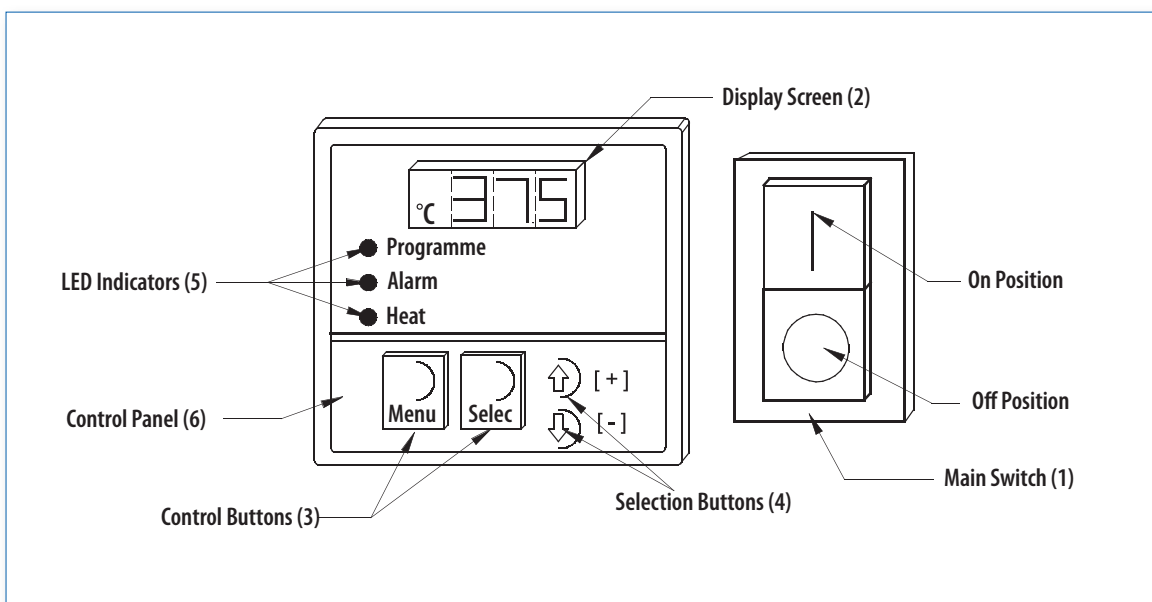

2. Avoid spilling acid solutions inside the incubator. These cause the incubation chamber material to deteriorate. Whenever possible, try to use substances whose pH is neutral. Avoid incubating substances generating corrosive vapours.
3. Avoid placing receptacles on the lower cover which protects the resistive heating elements.
4. Use personal protective elements when using the incubator: safety eyeglasses, gloves, tongs for placing and removing containers.
5. Avoid staying in front of an open incubator. Some substances emit vapours that should not be inhaled.
6. Calibrate the incubator where it is installed to establish its uniformity and stability.
7. Verify the operational temperature of the incubator in the morning and evening hours, with certified calibrated instruments (thermometer, thermocouple, etc.).
8. Register in the appropriate document or form each excursion detected in the incubator (i.e. temperature, humidity or CO<sub>2</sub> level) and any corrective action necessary.
9. **Daily:** Verify that the temperature in the incubator does not vary more than one degree centigrade (+/- 1 °C). Record temperature.
10. Add a non-volatile microbial inhibiting agent if water is needed inside the incubator to maintain a certain level of humidity.

### Cleaning recommendations

Clean cell culture or bacterial incubators regularly, **at least every 14 days** and after any infectious material spill, using appropriate disinfectants.

1. Disconnect the incubator before initiating the cleaning processes.
2. Use non-abrasive cleaning agents: a piece of cloth dampened with mild detergent for cleaning easily reached interior and exterior surfaces.
3. Avoid contact between cleaning agents and electric elements.
4. Wait until the incubator is dry (free of humidity) before connecting it again.

### Routine Maintenance

A well installed and operated incubator has few maintenance demands and many years can elapse before it requires any technical intervention. When any maintenance activity is performed, it must be done according to the manufacturer's recommendations.

**Warning:** Before performing any repairs, verify that the incubator has been *decontaminated, is clean and disconnected* from the electrical feed line.

The routine maintenance presented next must be carried out only by approved personnel with technical training on the incubator that are aware of the risks run in this type of activity. These routines focus on verifying the conditions and correct functioning of the following components:

1. **The door gasket.** This is generally made of a silicone base for which several years of use are guaranteed. In order to substitute the gasket, it is necessary to dismount the door and remove the mechanisms that fasten it to the door. In general, the gasket is mounted in a groove. The new gasket must have the same specifications as the original. Its mounting is done using the gasket's housing on the door and the fastening mechanism which can be as simple as a set of screws in some incubators.
2. **Heating elements** (system of resistors). The heating elements are generally located in the lower part of the incubator. In order to substitute them, it is necessary to dismount the panels and the lower covers of the incubator. In some incubators, the doors need to be dismounted as well (the exterior, metal, the interior, glass). Once the protective covers are removed, the resistors and the temperature sensor systems are disconnected and substituted by new ones with the same specifications as the originals. All removed elements are then reassembled, and a calibration is performed.
3. **Cooling ventilator.** In case of damage, this component must be substituted by a ventilator with the same characteristics as the original. To install, the compartment in which it is housed must be opened. In some incubators, it is necessary to dismount the doors and some protective panels. Once this is done, the damaged ventilator is disconnected and replaced by the new one, verifying that the air blows in the right direction. All dismounted elements are then reassembled.

For replacing the components mentioned below, proceed similarly as described for the previous components. It is very important to use replacement parts with the same specifications as the originals.

4. **Internal circulation ventilator.**
5. **Electronic control.**
6. **Electronic components.**
7. **Thermocouples.**
8. **Glass door (internal).**
9. **Handle.**
10. **Body of the incubator** (internal and external elements).

The common situations presented in the following table must be resolved by approved personnel with specialized training in incubator operation and maintenance. Special cases must be treated according to the manufacturers' recommendations.

**TROUBLESHOOTING TABLE**

**Standard incubator**

PROBLEM	PROBABLE CAUSE	SOLUTION
The incubator does not function.	There is no power in the electrical feed network.	Check the condition of the electrical connection.
	The on/off switch is in the off position.	Place the switch to the ON position.
	The electrical feed cable is defective.	Check the cable or replace it.
The incubator displays heating errors.	The temperature control is defective.	Check and adjust or replace the temperature control.
	The heating resistor is defective.	Replace the resistor with a spare one with the same characteristics as the original.
	The heating resistor connection is defective.	Clean connection points. Adjust the connection.
	The electric thermocouple is defective.	Replace the electric thermocouple.
	The temperature selected is lower than room temperature.	Check the incubator's specification. Only refrigerated incubators can operate in these conditions. Normally the ambient temperature is lower than that of the incubator.
	The relay is defective.	Replace the relay.
	The door gasket(s) is/are defective.	Change the door gasket(s).
The alarm remains on and the temperature is higher than that selected.	The temperature selected was changed to a lower value than the maximum limit of the alarm.	Wait until the temperature of the incubator goes down to the selected temperature.
	The temperature control is defective.	Replace the temperature control.
	The relay is defective.	Replace the relay.
The screen continually shows an error sign. Usually the LED displays the letters EEE.	The alarm diode is flashing.	Allow the incubator to cool until it stabilizes at the selected operational temperature.

**Low temperature incubator**

PROBLEM	PROBABLE CAUSE	SOLUTION
The incubator control does not function.	The switch is turned off.	Turn on the main switch.
	There is no electrical feed.	Verify the electrical feed circuit.
The temperature readings are erratic. (It is higher or lower than selected).	There is an accumulation of frost around the evaporator.	Defrost according to the procedure defined by the manufacturer.
		Reduce the cooling temperature.
The temperature in the incubation chamber is uniform, but higher than selected.	There is an accumulation of frost around the evaporator.	Defrost according to the procedure defined by the manufacturer.
	The flow of air in the interior is blocked by samples.	Reorganize the content of the incubator to allow the air to flow.
The temperature is higher or lower than selected.	The temperature control could require calibration.	Calibrate according to the procedure defined by the manufacturer.
The control is disconnected while in operation.	The voltage line is inadequate.	Verify the voltage line, this must not vary by more than 5% of the specified voltage indicated on the plate.
		The electrical connection is defective.
The compressor does not function although the cooling LED is on.	The thermal protector of the compressor is open.	Verify the voltage; it must not vary by more than 5% of the voltage specified on the plate.
Temperature readings are higher than those selected and set off the alarm over 40 °C.	The cooling relay is defective.	Replace the cooling relay.
	The compressor is defective.	Replace the compressor. Load the refrigerant and calibrate (this is a specialized procedure which requires special tools).



## BASIC DEFINITIONS

**Biochemical Oxygen Demand (BOD).** Amount of oxygen required by aerobic microorganisms to decompose the organic matter in a sample. It is used as an indicator of the degree of pollution of water. The (BOD) is measured as the mass in milligrams of oxygen used per litre of a sample when it is incubated at 20 °C over 6 days.

**LED** (*Light-emitting diode*). It is an electronic device which is widely used for displaying data on screens.

**Resistance.** Opposition that a material or electrical circuit imposes to the flow of electric current. It is the property of a circuit that transforms electrical energy into heat as it opposes the flow of current. The resistance [R], of a body of uniform section such as a wire, is directly proportional to the length [l] and inversely proportional to the sectional area [a]. The resistance is calculated by the following equation:

$$R = k \times \frac{l}{a}$$

Where:

k = constant that depends on the units employed

l = Length of the conductor

a = sectional area of the conductor

The ohm ( $\Omega$ ) is the common unit of electrical resistance; one ohm is equal to one volt per ampere.

**Thermal conduction.** This is a form of heat transference within a substance when heat flows from the point of higher temperature to that of lower temperature.

**Thermal convection.** This is a form of heat transference through the movement of fluid or air.

**Thermistor.** This is an electronic component, the resistance of which varies with temperature. They are low cost devices used in diverse applications; the most common one is temperature control.

**Thermocouple.** A device for accurate measurement of temperature consisting of two dissimilar metals joined together at one end, producing a small voltage which is proportional to the difference in temperature between the two when one of the connections has a higher temperature than the other. This phenomenon is known as the "Seebeck effect" in honour of its discoverer, the German physician Thomas Seebeck.

**Thermostat.** This is a device which regulates the temperature of a system. In general, it operates by expanding one of its components which mechanically activates another, for example a switch that controls a particular function.

# Chapter 15



## Microscope

<b>GMDN Code</b>	<b>36351</b>
<b>ECRI Code</b>	<b>12-536</b>
<b>Denomination</b>	<b>Microscopes</b>

The word *microscope* comes from the fusion of the Greek words *micros* which means *small* and *skopien*, *to see or examine*. This chapter presents the care and routine maintenance of microscopes used in clinical practice.

Depending on the contrast system, microscopes are given different names. Among the most common are the following:

- Clear field optical microscope
- Dark field optical microscope
- Fluorescence optical microscope
- Phase contrast optical microscope
- Interference optical microscope
- Polarized light optical microscope
- Inverted optical microscope
- Stereoscopic microscope

### PHOTOGRAPHS OF MICROSCOPES

#### Stereoscopic microscope



Photo courtesy of Olympus

#### Binocular microscope



Photo courtesy of Nikon Instruments

▲ This type of microscope uses various systems of lenses and controlled illumination to achieve magnification of an object.

◀ This type of microscope allows tridimensional images or volumes to be appraised by superimposing two single images, one for each eye, over each other.



**PURPOSE OF THE EQUIPMENT**

The microscope is a precision instrument with optical subsystems (lenses, filters, prisms, condensers); mechanical subsystems controlling the position of the sample in tri-dimensional space X, Y, Z; electrical (transformers and light source) and electronic subsystems (cameras, video, etc.) interacting to amplify and control the image formation of objects which are not detectable to the human eye. To observe samples, it is essential to prepare these according to techniques which emphasize details to be observed.

The microscope constitutes a diagnostic aid of first order in healthcare, in specialties such as haematology, bacteriology, parasitology and in the training of human resources (there are microscopes with specialized additions for students to carry out observations directed by a professor). The technical developments applied to microscopes have allowed the design of numerous specialized models by the industry and academia. These play a key role in developing human knowledge and understanding the workings of nature.

**OPERATION PRINCIPLES**

The microscope is constructed using the physical properties of lenses interacting with light. A lens is an optical element usually made of glass which can refract light. It is of calculated dimensions and in general has parabolic or spherical surfaces. If light rays reaching one surface of the lens converge in a common point F when exiting it, such lens is known as positive or convergent. If it disperses the light rays crossing it, it is divergent or negative. Positive lenses (convergent) shown in Figure 41 constitute the building blocks of microscopes.

In Figure 41, it is possible to identify the *focus* [F], (the point where the light rays are concentrated) and how light is refracted across the lens. The distance between the lens and the focus is known universally as the *focal distance* [D].

Figure 42 summarizes concepts related to the functioning of lenses applied to the design of microscopes.

**Figure 41. Positive (convergent) lens**

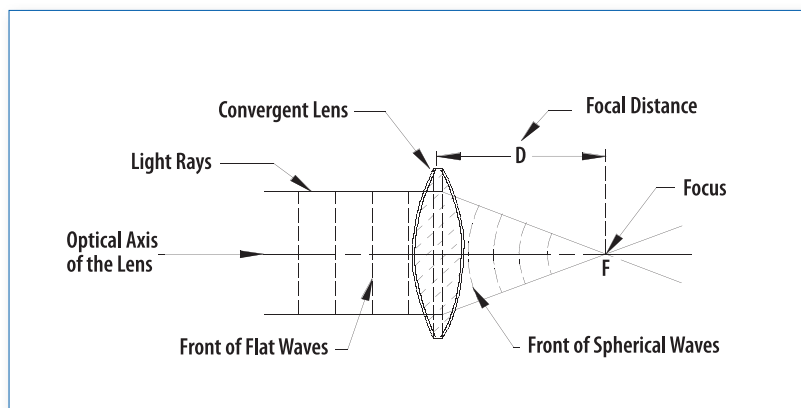

**Figure 42. Optics of the convergent lens**

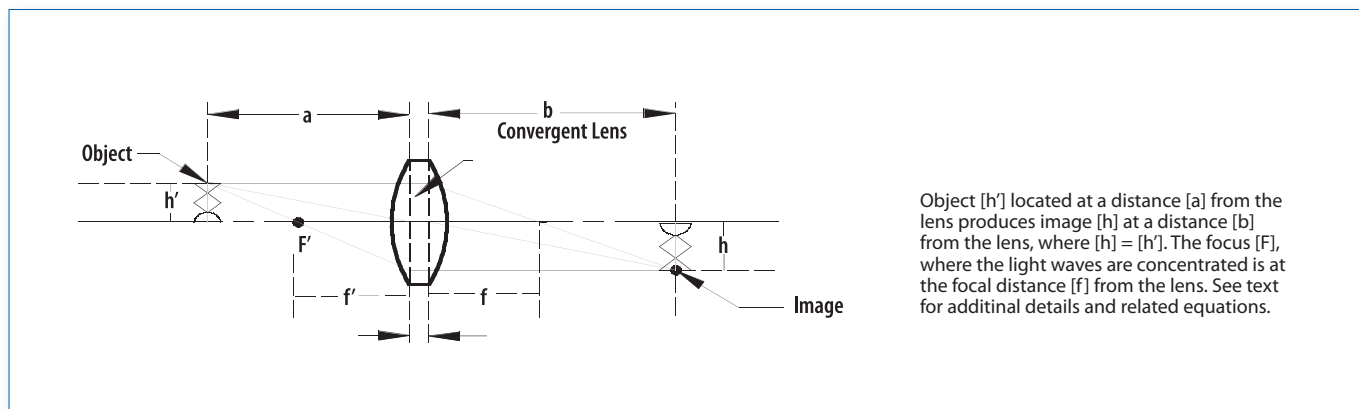

Object [ $h'$ ] located at a distance [ $a$ ] from the lens produces image [ $h$ ] at a distance [ $b$ ] from the lens, where [ $h$ ] = [ $h'$ ]. The focus [F], where the light waves are concentrated is at the focal distance [ $f$ ] from the lens. See text for additional details and related equations.

When an illuminated object [h] is placed at a distance [a] in front of a convergent lens, light rays cross the lens and are refracted. A ray crossing the upper part of the object crosses the optical axis of the lens at the focal point [F]. It is refracted by both surfaces of the lens and exits in one direction, parallel to the optical axis. The ray crossing the upper part of the object in parallel with the optical axis passes through the lens and is refracted. It then travels through the focal point [F] on the image's side until it crosses the first ray at a distance [b] from the lens where the image is formed. In the case shown in Figure 42, the distance [a] is greater than the focal distance [f], where a real image is formed inverted at a distance [b] behind the lens. The focal distance [f] is related to the distances [a] and [b] in the equation:

$$\frac{1}{f} = \frac{1}{a} + \frac{1}{b}$$

The magnification [M] of a lens, defined by the relationship between the size of the object and the size of the image formed is represented by the equation:

$$M = \frac{h}{h'} = \frac{b}{a}$$

Where:

[h] and [h'] correspond respectively to the dimensions of the image and the object; [a] and [b] to the distances between the lens and the point where the image is formed and between the lens and the point where the object is located.

Figure 43. Diagram of a microscope

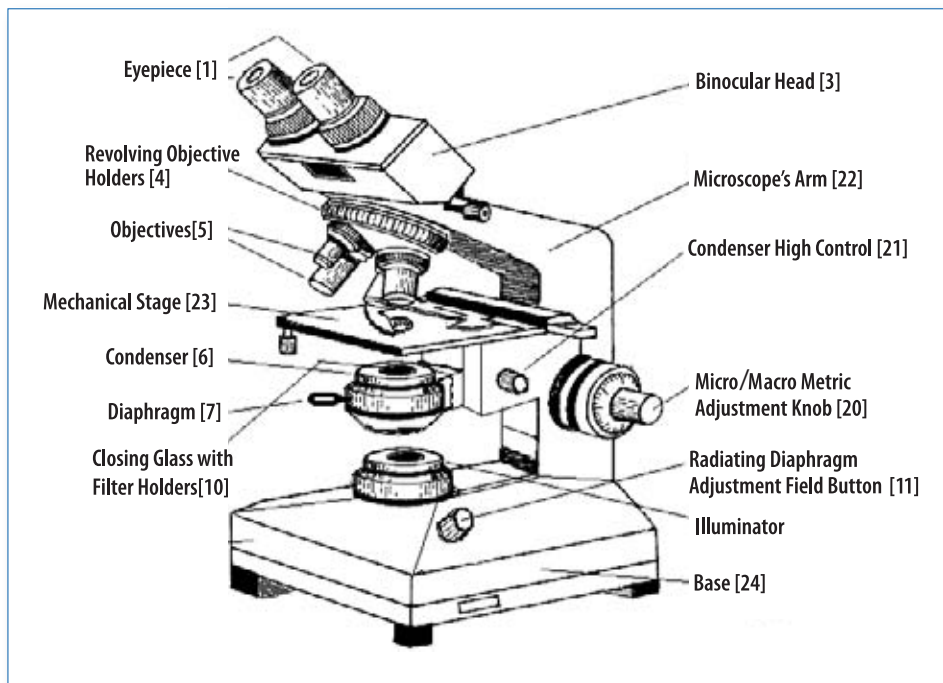



**Components**

The main components of the microscope subsystems are shown in the table below.

**INSTALLATION REQUIREMENTS**

Normally, microscopes use 110 V/60 Hz or 220 V/60 Hz power. Some have a regulated source which allows light

intensity adjustments. Other microscopes use a mirror through which light is directed towards the slide located on the platform rather than a lamp. Such microscopes are mostly useful in regions far from urban centres, where there are no electricity lines and are used by health brigades. Certain types of microscopes require special installations; a fluorescence microscope needs a dark cabinet in order for observations to be carried out.

**Figure 44. Cross-section of a microscope**

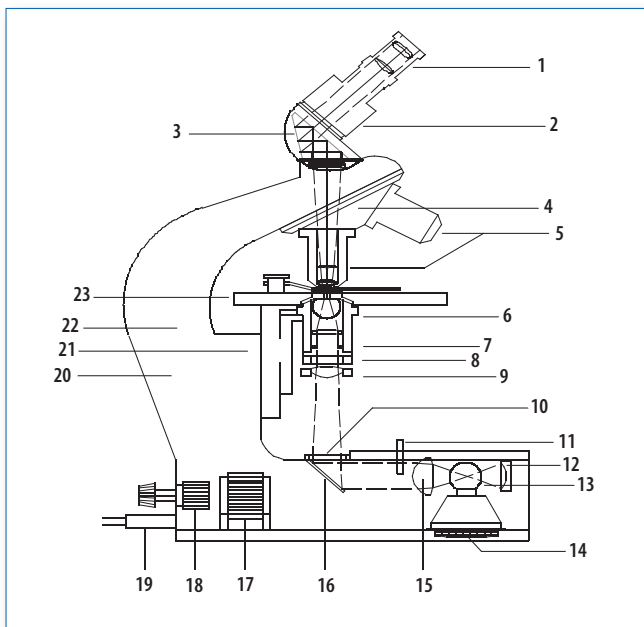

**Legend**

No.	System	No.	Components
1	Binocular head	1	Eyepiece
		2	Binocular tube
		3	Binocular head
2	Revolving objective holders	4	Revolving objective holders
		5	Objectives
3	Platform, plate or mechanical stage and condenser	6	Condenser
		7	Aperture diaphragm
		8	Filter holders
		9	Wide range lens
		21	Condenser control
		23	Platform, plate or mechanical stage
4	Illuminator	10	Closing glass with filter holders
		11	Settings lever of the diaphragm's light field
		12	Concave mirror
		13	Incandescent light
		14	Light holder with adjustment ring
		15	Collector lens
5	Microscope's body	16	Mirror
		17	Internal transformer
		18	Control rheostat
		19	Feed cable
		20	Macro/micro metric adjustment knob
		22	Microscope's arm
24	Base		



## DESCRIPTION OF POTENTIAL PROBLEMS WITH MICROSCOPES

Figure 45. Binocular head

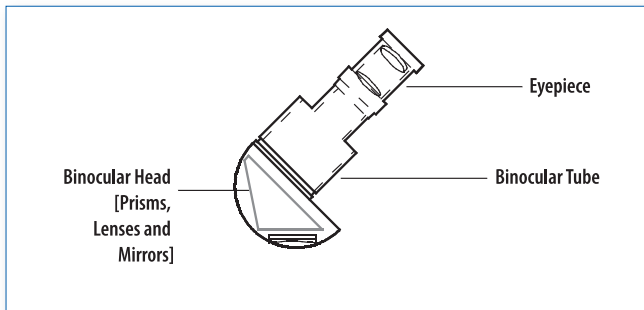

### Eyepieces

The most frequent problem affecting eyepieces is the presence of dust and grime, which may be on the external or internal surfaces. Such dust or grime produce shadows interfering with the sample under analysis, especially when high powered lenses are used (40X–100X). If these are external, cleaning the surfaces of the lenses solves the problem. If internal, it is necessary to disassemble the eyepiece, clean the internal surfaces, reassemble and verify the final state.

Scratches may be observed on the eyepieces' lenses, especially on those that have been in service for a long time. These are produced by negligence during the cleaning process due to the use of inadequate material for cleaning. Scratches produce cobweb-like shadows in the visual field of the eyepieces. Unfortunately with this type of damage, the eyepieces must be changed. Sometimes the focus mechanisms of the eyepiece stick. To repair, the eyepiece is disassembled; the appropriate solvent is applied to its threading and the focus mechanism is cleaned and reassembled. If the lenses of the eyepiece show ruptures due to abnormal circumstances (marks due to falls, unsuitable use), the eyepieces must be changed.

### Binocular head

The state of the binocular head has a direct effect on the quality of the microscope's image. Its most important components are the prisms and mirrors. Grime adhered to the optical components of the head affects the quality of the image. This component can even become dirty due to normal work in the laboratory, such as changing the eyepieces, installing accessories (e.g., cameras) or simply by forgetting to place stoppers when the microscope is not in use.

- **Prisms.** These have silver-plated reflective surfaces which can become rusty over time and lose their reflecting capacity. Some prisms have only one coat of reflective paint on their surface through which light

enters and leaves. If the reflective surface is damaged, the prism can be removed, cleaned, polished or repainted, installed and aligned in the binoculars head. This kind of maintenance is highly complex and can only be done by specialized laboratories or companies offering this maintenance service. The removal of prisms without training and suitable tools can have a serious impact on the quality of the image and even break the component.

- **Mirrors.** These have reflecting surfaces directly exposed and are susceptible to rust. If repair is necessary, the mirror is dismounted and removed from the binocular head and substituted by a new one, cut, cemented and aligned directly where it is being mounted.

Figure 46. Lighting system

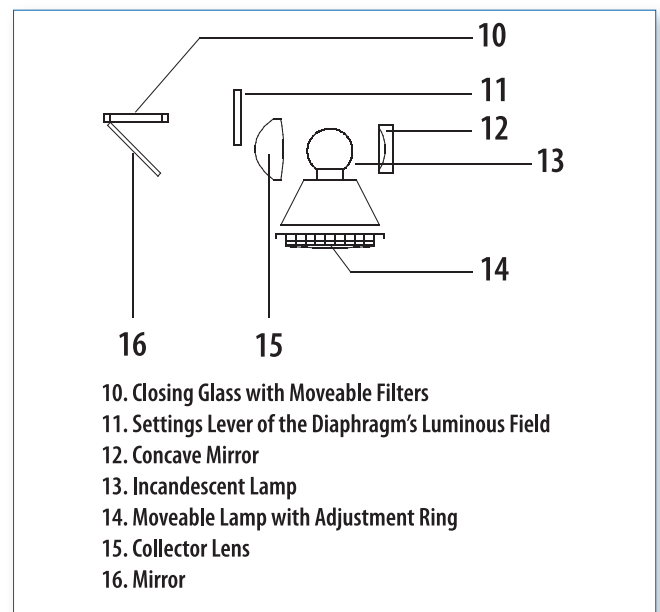

This is a fundamental element of the microscope. If the illumination system does not work well, the microscope is out of order as light intensity and contrast are fundamental to observe samples. Several factors may affect the lighting system; the most common ones are grime and deterioration of the mirrors and lenses, defects in the feed voltage, or the use of bulbs other than those recommended by the manufacturers. The anomalies mentioned produce small shadows in the vision field and insufficient light intensity, or a lack of homogeneity in the lighting.

### Internal dust and grime

This occurs when the lighting systems are not sealed to prevent dust and particle infiltration. Dust in the system produces diffusion and a decrease in the quantity of light projected onto the sample. Large particles produce shadows rendering observations difficult. In order to correct the problem, the illuminator is disassembled, its components cleaned, reassembled and realigned.

### Mirrors

The mirrors have a reflective coating directly on their surface. In recently manufactured microscopes these generally have a protective coat. In older equipment, the reflective coat is exposed to rust.

### Incandescent bulb

The bulb is a consumable component with a determined operational life. Its acquisition must be planned ahead to ensure a replacement is always available in the laboratory or in the institution where the equipment is installed. The bulb installation is done according to the manufacturer's instructions. Some equipment, such as the fluorescence optical microscope, uses special bulbs (mercury or xenon light) requiring mounting and calibrating procedures which, although simple, must be carried out according to the manufacturer's recommendations. The voltage supplied to the microscope must correspond to that specified by the manufacturer. Otherwise, unnecessary risks which may affect the quality of lighting are taken. Note that some microscopes use internal or external transformers and voltage regulation systems.

**Figure 47. Platform, plate or mechanical stage**

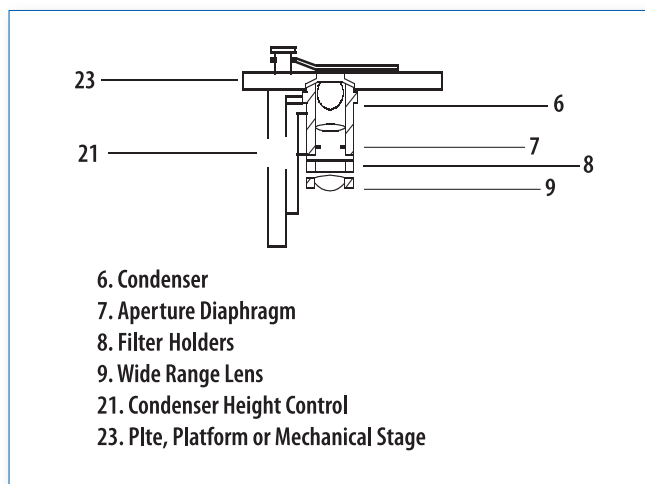

### Condenser

The condenser controls how the light is concentrated on, or contrasted against the sample under observation. It is composed of optical and mechanical elements. The optical elements are the lenses and the mechanical ones those which allow the control of the position of the lenses and the quantity of light reaching the sample through a mechanical diaphragm.

Normally, optical components are affected by the presence of dust. These must be cleaned in a similar manner to lenses, using a fine camel hair brush to remove dust deposited on the surface. The mechanical components require adjustment by tools with special characteristics and each manufacturer has its own designs. The usual routines are focused on cleaning, adjustment and lubrication procedures.

### Plate or sample holders

The plate or sample holder comprises a series of components interacting with each other. Their purpose is to control the position of the sample under analysis. The plate has movement capability in the direction X/Y, which the operator controls with independent macro/micrometric buttons. Beside it, the plate has tension devices to allow smooth sliding using "milano tail" type guides, which are normally lubricated. In its upper part, are installed plates or control gripping devices for the specimen slides. Maintenance seeks to keep these mechanisms clean, lubricated and well adjusted.

**Figure 48. Revolving, objective holder**

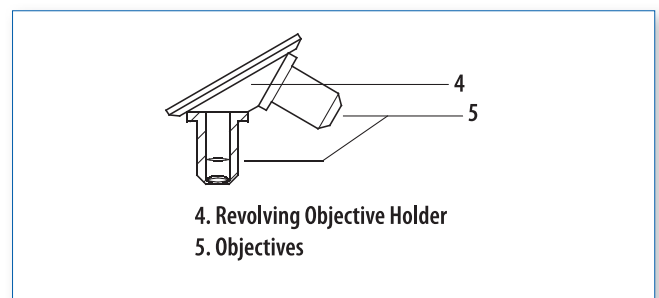

The maintenance of the revolving objective holder is simple. It has an internal catch mechanism which allows the objective in use to be aligned with the optical microscope equipment. It simply rotates smoothly until a trip mechanism adjusts the correct position of the next objective. Each manufacturer defines the number of objectives which can be mounted on the revolver. The most common revolvers can hold between three to five objectives. Maintenance seeks to keep the rotating mechanism clean, lubricated and well adjusted.

The objectives should receive routine cleaning of their external optical surfaces. Immersion type objectives require that oil is cleaned off after each use to avoid the objective's internal optical structure from being contaminated with oil through capillarity.

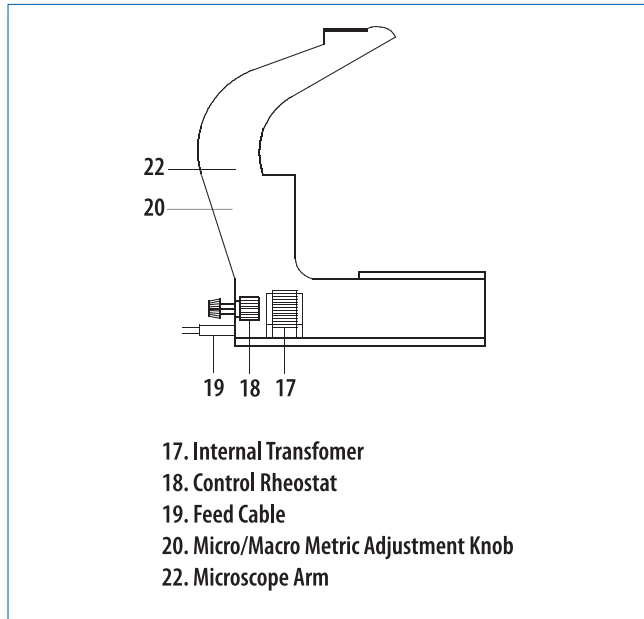
**Figure 49. Body of the microscope**

The microscope's body is designed to receive and support the components already described (binocular head, mechanical stage, condenser and revolving objective holder, other components such as the transformer and electrical/electronic elements of the microscope's lighting system).

Maintenance of the microscope's body basically consists in keeping its surface clean, removing grime, dust or elements affecting its presentation and state. It is necessary to take special care with chemical substances that may be corrosive, including dyes used in the laboratories for staining slides.

### GENERAL MAINTENANCE OF THE MICROSCOPE

Above all, it is necessary to emphasize that the microscope is high precision equipment. The integrity of its optical components, both mechanical and electrical, must be preserved in order to preserve it in the best condition. Each element of the microscope has been developed using the most advanced manufacturing techniques. Its assembly and adjustment are done in the factory using specialized equipment. During this process the required tolerance of the various components of the equipment is highly controlled through advanced measuring techniques. The cleaning of the microscope environment, its installation and careful use are fundamental to achieve a long and operational life. Humidity, dust and bad conditions of the electrical feed, misuse or inadequate installation are counterproductive for its conservation. Microscope maintenance involves a lot of care, patience and dedication. It must only be carried out by trained personnel using specialized tools. General recommendations are presented next. These are required for installing and maintaining a microscope in good working condition.

### Installation and storage

1. Ensure that the area where the microscope is installed is protected from dust and humidity. Ideally, there must be an air-conditioning system which guarantees air free from dust or particles, humidity control and permanent temperature control.
2. Verify that the area is secure, having a door with a lock to prevent unauthorized removal.
3. Confirm that the location of the microscope is far from water supplies or where chemical substances are handled in order to avoid spills or splashing. Also, areas with direct sunlight must be avoided.
4. Verify that the area selected has an electrical outlet compatible with the lighting system of the microscope. It must be in good condition with voltage adjusted to the magnitude and frequency of the electric codes and standards. If the microscope uses a mirror, it must be located near a window which allows good illumination, but it should not be directly exposed to sunlight.
5. Install the microscope on a levelled surface of a rigid structure, under which there is sufficient room for the user (the microscopist) to place his/her legs. His or her body should be close to the microscope with the head near the eyepieces without strain of the vertebral column, neck and back.
6. To facilitate the microscopist work position, provide a chair of adjustable height with good back support. If there is no back support; provide support for the feet, placing it at the front of the work space (not on the chair). The purpose of this is for the vertebral column to be as erect as possible and to reduce flexing of the shoulders and neck.
7. Avoid locating microscopes near equipment which produce vibrations such as centrifuges or refrigerators.
8. Try not to move the microscope from its installation position, especially if it is used intensely each day.
9. Cover the microscope with a dust protector if not used for long periods of time, taking precautions so it is not affected by excessive humidity. The dryer the environment, the lower the probability fungi will grow. The protector can be of plastic or cloth of similar quality to that of handkerchiefs which do not deposit lint.
10. In areas of high humidity, keep the microscope in a box or cabinet lit with a bulb of no more than 40 W during the night. This helps keeping the storage area dry and reduces the probability of fungal growth. If this alternative is used, verify that there are some openings permitting ventilation inside.

### Cleaning procedures

Cleaning of the microscope is one of the most important routines and must be considered essential. The following materials are required:

1. A piece of clean cloth with a similar texture to that of a handkerchief.
2. A bottle of lens cleaning solution which can be obtained from opticians. Normally, it does not affect the lenses' protective coating nor the adhesives or cements used in their assembly. Among widely used cleaning liquids are ethyl ether, xylene and white gasoline.

**Warning:** Some manufacturers do not recommend using alcohol or acetone as these can affect (dissolve) the cements and adhesives used for attaching lenses.

3. Lens paper. This can normally be obtained from opticians. If it is not possible to obtain this material, it can be substituted with soft absorbent paper or with medicinal type cotton. Also a piece of soft silk can be used.
4. A piece of very fine chamois. This can be obtained from shoe shops.
5. A rubber (nasal) bulb for blowing air. A device can be made in the laboratory by connecting a Pasteur pipette to the rubber bulb.
6. A plastic cover to protect the microscope from its external environment when not in use. A cloth bag with a texture similar to handkerchief material can also be used.
7. A soft camel hair brush or a fine paint brush. Importantly, the brush's hair should be natural, of uniform length with a very soft texture, dry and free from grease. It is possible to obtain this in photography stores. Also, it is possible to find an equivalent in shops supplying cosmetics.
8. A 250 g packet of desiccant (silica gel). This is used to control the humidity in the microscope's storage box if it is airtight. It changes colour when it is saturated by humidity to detect when it needs to be substituted or renewed. When it is in good condition, the colour is generally blue; when it is saturated with humidity, it is pink.
9. Bulbs and replacement fuses. These should be of the same model as those installed by the manufacturer or of equivalent characteristics.

**Note:** All required materials for cleaning must be kept clean and stored in containers that protect them from their external environment.

### Cleaning of the optical elements

In a microscope, there are two types of optical elements: those external in contact with their outside environment and those internal, inside the body of the microscope and more protected (objectives, eyepieces, mirrors, prisms, condenser, illuminator, etc.). The cleaning procedures, although similar, differ with regard to the care and precautions.

1. The external optical elements of eyepieces, objectives, condenser and illuminator are cleaned by gently brushing their surfaces with the camel hair brush. This removes dust particles. The rubber bulb is then used to blow streams of air onto the lenses' surface to ensure that these are free from dust. If dust is found adhered to the optical surface, a piece of very soft clean cloth is used with small circular movements, without exercising too much pressure on the lens. The nasal bulb is used again to blow air on the lens to remove adhered particles. A piece of fine chamois can also be used. If so, place the chamois at the end of a small cylindrical object with a slightly smaller diameter than that of the lens. Without exercising much pressure, rotate gently on the lens surface. Finally, air is blown onto the lens surface with the nasal aspirator. This is sufficient to clean the external surfaces. The piece of chamois can be humidified with distilled water if necessary.
2. Under adequate conditions of installation, interior surfaces of optical elements should not be affected by dust or particles. If for some reason, particles are detected, it is necessary to open them to carry out the cleaning process. An eyepiece or objective must never be opened if there is not a clean environment to carry out the cleaning procedure. Clean with a camel hair brush and with the nasal aspirator according to the procedure explained previously. It is not recommended to dismount the objectives for any reason as this could alter the tolerances achieved by the manufacturer. If dismounted, it would be necessary to realign the elements and this is only feasible if the manufacturer's precise instructions are followed. Cleaning of the objectives will be limited to keeping the front and back lenses clean.
3. If immersion oil residues are detected on the lens surface, remove using lens paper or medicinal type cotton. The lens' surface must be then cleaned with a solution composed of 80 % ether petroleum and 20 % 2-Propanol.

### Cleaning of the microscope's body

1. The microscope's body can be cleaned with a detergent solution to remove external filth and cut the grease and oil. This must be applied with a small brush. After the grease and filth have been removed, the microscope's body must be cleaned with a 50/50 solution of distilled water and 95% ethanol.

**Note:** This solution is not adequate for cleaning optical surfaces.

2. The parts integrated in adjustment mechanisms for the macro/micrometric (thick and fine) adjustment, the condenser and the stage or platform must be lubricated periodically with refined machine oil to facilitate smooth movement.

### Microscope maintenance

Among the most important steps for maintaining a microscope in suitable operation conditions are the following:

1. Verify the adjustment of the mechanical stage. It must move gently in all directions (X-Y) and must stay in the position selected by the microscopist.
2. Test the focus adjustment mechanism. The focus selected by the microscopist must remain stable. The height must not change from that assigned by the microscopist.
3. Verify the functioning of the diaphragm.
4. Clean all the mechanical components.
5. Lubricate the microscope according to the manufacturer's recommendations.
6. Confirm the adjustment of the specimen holder (gripping device).
7. Verify the optical alignment.

### Precautions

1. Avoid cleaning optical components with ethanol because it affects the optical elements. Also, do not clean the base of the platform with xylene or acetone.
2. Do not use ordinary paper to clean lenses as it could scratch their surface.
3. To prevent leaving fingerprints, do not touch lenses with bare fingers.
4. Do not clean the eyepieces' lenses or objectives with cloth or paper, because the coating covering the optical elements could deteriorate. Clean these surfaces with a camel hair brush or by blowing air with a nasal aspirator.
5. Avoid leaving the microscope without the eyepieces. Place stoppers on these to prevent dust and particles from entering the binocular head.
6. Do not leave the microscope stored inside a box in humid environments.
7. Avoid pressing the objective against slides as it could damage the thin lamina or its front lens. Adjust the focus slowly and carefully.
8. Keep the platform or mechanical stage clean.
9. Do not disassemble optical components since this can produce misalignments. Optical surfaces must be cleaned first with a camel hair brush and then with a chamois or lens paper.
10. Use both hands for lifting the microscope, one hand supporting the microscope arm and the other supporting its base.
11. Avoid touching the surface of the bulb with fingers when changing it. Fingerprints decrease the light intensity.
12. Verify that the feed voltage is correct in order to prolong the life span of the bulb. Whenever possible, use the lowest light intensity needed for carrying out observations.

13. Connect the microscope to a voltage stabilizer if the feed voltage is not stable.

### Special care in warm climates

In warm climates as well as in dry ones, the main problem affecting the microscope is dust since it affects the mechanical and the optical systems. This problem can be controlled by the following steps:

1. Always protect the microscope with a plastic cover when not in use.
2. After use, clean the microscope by blowing air using a nasal aspirator.
3. Clean the lenses with a camel hair brush or with an air brush. If the dust stays adhered to optical surfaces, try to remove it with lens paper. However, rub the surface very gently to avoid scratches.

### Special antifungal care in humid climates

In humid and generally warm climates, microscopes can be affected by fungi growing mainly on the surface of lenses, in the grooves of screws and under the protective paint. If the equipment is not adequately protected, it could become useless in a short period of time. The following care instructions will assist in preventing the formation of fungus.

1. At night, store the microscope in a box equipped with an electric light of no more than 40 W. The bulb must be installed in the upper part of the box, near the binocular head and must be kept on during the night. The box must have some openings to allow the air to circulate. The temperature inside the box must not exceed 50 °C so that properties of the microscope's lubricants are not affected.
2. If it is not possible to use a box with electric light, as an alternative, a drying agent such as silicone gel or rice can be used. When a drying agent is used, verify that the microscope is kept in a protected box or under a cover made of fabric similar to that of a handkerchief. Verify that the drying agent is in good condition. If this is not the case, substitute it.
3. Clean the microscope periodically. Use latex gloves if lenses must be touched. This will prevent leaving any fingerprint and decrease the risks of fungal growth.
4. If none of the mentioned alternatives is feasible, put the microscope in a place with good air circulation. When the microscope is not in use, it may be located under direct solar light, for short periods. This reduces the humidity and the risk of fungi growing on the surfaces of the equipment.
5. Air conditioning (temperature and humidity control) significantly prevents fungal growth on microscopes. However, this is not an option for a great number of laboratories. If the air conditioning service is not continuous in the area where the microscope is installed, precautions must be taken to control the humidity.

**Removal of fungal hair**

1. Check and clean the microscope frequently using the procedures mentioned in this chapter. Control the humidity conditions where the microscope is stored. If adequate ventilation is maintained, it decreases the possibility of fungal growth on the microscope.
2. If fungal growth is detected, use a small piece of cotton dampened in an antifungal solution, normally ether or xylol (xylene). Rub gently making circular motions on the entire surface of the lens. An oscillatory movement can also be used, towards the front and back or left-right-left, exercising a very moderate pressure on the surface of the lens. If necessary, repeat the procedure with a new piece of cotton.
3. When removal of the fungal hair is completed, clean with a small piece of clean cotton.

**Microscope care****Frequency: Daily (after use)**

1. Clean the immersion oil off from the 100X objective. Use lens paper or, if not available, use medicinal type cotton.
2. Clean the sample holders.
3. Clean the condenser.
4. Place the light intensity control rheostat in the lowest position and then turn off the lighting system completely.
5. Cover the microscope with a protective cover (of plastic or cloth). Ensure that it is kept in a well ventilated place where the humidity and temperature are controlled. If it has a ventilated storage box equipped with a light bulb for humidity control, place the microscope inside, turn on the light and close the box.

**Frequency: Each month**

1. Remove dust particles from the microscope's body. Use a piece of cloth dampened with distilled water.
2. Remove dust particles from the eyepieces, objectives and condenser. Use a rubber bulb for blowing air. Next, clean the lenses' surface with lens cleaning solution. Do not apply this solution to lenses directly, but on lens paper and then rub their surfaces gently with the wet paper.
3. Remove the slide holder mechanism, clean carefully and reinstall.

**Frequency: Every six months**

As a complement to the monthly maintenance routines, the following are recommended:

1. Carry out a general visual inspection of the microscope. Verify that each component is in good condition, clean and mechanically well adjusted.
2. Verify that good ventilation conditions, temperature and humidity control are maintained in the place of installation.
3. Test the quality of the electric system that feeds the microscope. Verify the integrity of the connectors, fuses and of the incandescent light.

**TROUBLESHOOTING TABLE**
**Lighting system**

PROBLEM	PROBABLE CAUSE	SOLUTION
The lighting system does not come on.	The electrical feed cable is disconnected.	Connect the electrical feed system.
	The protection fuse is burnt out.	Replace the protection fuse.
	The bulb is burnt out.	Replace the light bulb. Ensure it is well aligned.
	The lighting switch is defective.	Replace the switch.
The lighting system is not producing uniform light.	The electrical system shows voltage errors.	Check and repair the electrical system. Connect the microscope through a voltage stabilizer.
	The microscope's connector to the wall outlet is slack.	Connect the plug to the outlet. If any of the elements are defective, replace it.
	The bulb is badly installed and is not making good contact.	Reinstall the bulb.
	There are metal or black specks on the bulb's surface.	Replace the light bulb.
The sample is not illuminated in a uniform manner.	The light source is not centred.	Rectify the alignment of the condenser.
	The objective is not well centred.	Slowly turn the revolving objective holder until the adjustment catch sound.
The sample is poorly illuminated.	The diaphragm's iris is almost closed.	Open the diaphragm's iris until the lighting is adequate.
	The condenser is very far (very low).	Bring the condenser closer.
	The condenser's lenses show dust or fungal growth.	Clean the condenser. Remove the dust with a brush. Remove the fungi with a lens cleaning solution.
There is excessive contrast in the image.	The diaphragm's iris of the condenser is almost closed.	Open the iris of the diaphragm slightly.
The image is slightly too clear and shiny.	The diaphragm's iris of the condenser is very open.	Close the diaphragm's iris slightly.

**Optical/mechanical system**

PROBLEM	PROBABLE CAUSE	SOLUTION
The mechanical stage does not stay in position and the image is continually going out of focus.	The adjustment tension of the mechanical stage is slack.	Adjust the tension mechanism of the mechanical stage.
The mechanical stage cannot be raised to its higher limit.	The mechanical stage is locked very low.	Loosen the locking mechanism of the mechanical stage. Adjust to the desired height. Readjust the locking mechanism.
There is poor quality of the image with objective 40X.	The lenses show fungi.	Remove the fungi using a cleaning solution. Follow the manufacturer's instructions regarding the device.
	The lenses are damaged.	Check the objective. Verify if the lenses show scratches, punctures or nicks. Replace the objective.
	The lenses are accidentally smeared with immersion oil.	Remove the oil carefully with lens paper.
The immersion objective does not give clear images.	The objective is being used without immersion oil.	Place immersion oil on the slide.
	The immersion oil is of a low refraction index.	Use good quality oil.
	There is immersion oil in the interior of the objective.	Clean the lenses with lens paper. If cleaning the outside is not the solution, send the objective to a specialized laboratory for repair. (Dismount the lenses, clean, change the seals, cement, realign and assemble).
Dust or visible dirt is in the field of vision.	Dust present on the collector lens of the light source.	Remove particles of dust with a camel hair brush.
	Dust present on the upper lens of the condenser.	Remove the dust particles with a camel hair brush.
	There is dust on the eyepiece.	Remove the particles of dust with a camel hair brush.



## BASIC DEFINITIONS

**Acetone.** This is a colourless, flammable liquid with an excellent capacity to mix with water; a solvent used for a great number of organic substances. Boiling point: 56 °C. Chemical formula:  
 $\text{CH}_3 - \text{CO} - \text{CH}_3$

**Diaphragm.** This is a device which controls the flow of light through the microscope. There are two types of diaphragms: the aperture diaphragm which adjusts the angle of the aperture in the microscope, and the field diaphragm which regulates the size of the image. The purpose of the diaphragms in optical microscopes is to prevent rays of light with severe aberrations from reaching the image formation levels and to ensure an adequate distribution of light in the sample as well as in the image's space.

**Ethanol.** This is a colourless liquid also known as ethylene alcohol. A widely used industrial solvent, for example in the pharmaceutical industry. Its density is 0.806 g/cm<sup>3</sup>, boiling point 78.3 °C and chemical formula:  
 $\text{CH}_3 - \text{CH}_2\text{OH}$

**Ether.** This is a liquid substance derived from alcohol by eliminating one molecule of water between two molecules of alcohol. It is an excellent solvent which is not very soluble in water and is very volatile and flammable. Its boiling point is 35 °C and chemical formula:  
 $\text{CH}_3 - \text{CH}_2 - \text{O} - \text{CH}_2 - \text{CH}_3$

**Eyepiece.** Set of lenses through which the microscopist observes the image (real or virtual image depending on the relationship that exists with other sets of microscope lenses).

**Field depth.** The specimen or sample's compactness which is reasonably clear at a determined level of focus.

**Field of vision.** The surface area seen when looking through the microscope. The area decreases with increasing power of magnification. The diameter of the field of vision is measured in millimetres (mm) on the intermediate plane of the image. The field of vision in an optical microscope at a particular magnification is expressed as its diameter in mm or simply as a number.

**Focus.** The point where, as a result of the light's refraction, the light rays passing through a lens are concentrated. If the light rays converge in one point, the lens is positive and the focus is real; if the light rays diverge, the lens is negative and the focus virtual.

**Focus depth.** A range at which the image plane can be moved maintaining clarity.

**Numerical aperture.** This is a measurement of the capacity of an objective to concentrate light and distinguish minute details of an object. Normally, the value of the numerical aperture is recorded on the side of the objective's body. Greater values of numerical aperture allow a greater number of oblique rays of light to pass through the objective's front lenses, producing a higher resolution of the image. It is expressed mathematically as:

$$\text{NA} = n \sin(\phi)$$

Where:

NA = numerical aperture

n = refraction index (n = 1 air; n = 1.52 immersion oil)

$\phi$  = aperture angle. At a greater the angle, a greater thenumerical aperture, a greater resolution

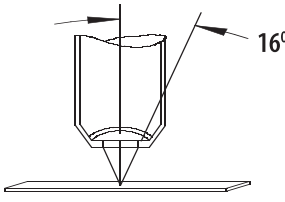
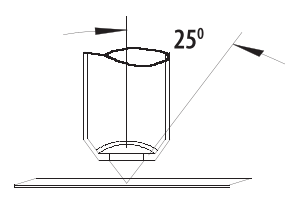
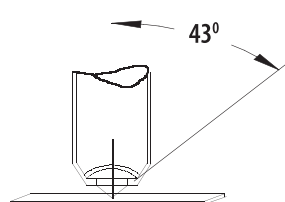
Numerical aperture	Mathematical expression
	$\text{NA} = n \times \sin \phi$ $0.27 = 1 \times \sin(16^\circ)$ Magnification approx. 10X
	$\text{NA} = n \times \sin \phi$ $0.42 = 1 \times \sin(25^\circ)$ Magnification approx. 20X
	$\text{NA} = n \times \sin \phi$ $0.68 = 1 \times \sin(43^\circ)$ Magnification approx. 40X

**Propanol.** Also known as isopropyl alcohol and prepared by the hydration of propylene. It is used as a solvent as well as in the preparation of acetone. Its boiling point is 83 °C and chemical formula:



**Range of useful magnification.** [RUM] of an objective/eyepiece combination is defined by the numerical aperture of the system. For perceiving the details of an image, a minimum magnification traditionally between 500 and 1000 times the numerical aperture [NA] of the objective is required. {Acceptable from RUM = (500) x [NA] to (1 000) x [NA]}.

**Refraction index.** Value calculated by comparing the speed of light in space and in a second medium of greater density. It is normally represented by the letter [n] or [n'] in technical literature or in mathematical equations.

**Resolution.** The ability to distinguish the finest details from a slide or particular sample. Among factors which most influence achieving a good resolution are the numerical aperture, the type of sample, the lighting, the aberration correction and the type of contrast used. It is one of the most important characteristics of the microscope.

**Revolving objective holder.** Mechanical device designed for mounting the objectives and allowing rapid interchange by means of a rotational movement. Its capacity depends on the type of microscope. In general, it varies between three and five objectives.

**Xylene.** Ethyl benzene isomer obtained from coal. It is used as a solvent and also in the preparation of dyes and lacquers. Its boiling point is 138 °C / 144 °C and chemical formula:

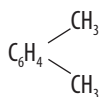



# Chapter 16

## Pipettes

<b>GMDN Code</b>	<b>15166</b>
<b>ECRI Code</b>	<b>15-166</b>
<b>Denomination</b>	<b>Pipettes</b>

Pipettes are devices used for measuring or transferring small volumes of liquid from one container to another with great precision. There are many pipette models. Initially, they were made of glass; at present, there is a wide range of options. Fixed volume and variable volume pipettes with mechanical controls are highlighted herein. Recently, pipettes with electronic controls have been introduced into the market. This chapter deals with aspects referring to the maintenance and calibration<sup>1</sup> of mechanical pipettes.

<sup>1</sup> Calibration must be done exclusively by trained personnel according to current international standards as BS ES ISO 8655-6:2002 or updated ones. Reference work instruments must be suitably calibrated by national or international institutions, responsible for verifying the compliance with international measurement standards.

### PHOTOGRAPHS OF PIPETTES

#### Single channel pipette



Photo courtesy of Gilson S.A.S.

#### Multichannel pipette



Photo courtesy of Eppendorf AG

Figure 50. Diagram of a pipette

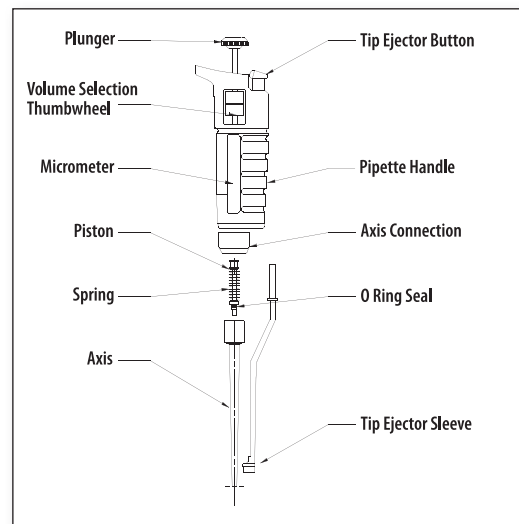

## PURPOSE OF THE PIPETTES

Pipettes are devices widely used in clinical and research laboratories to supply very exact quantities of fluids.

## OPERATION PRINCIPLES OF THE PIPETTE

The mechanical or piston pipette generally functions by manually transmitting force exercised on a plunger. The plunger is an axis connected to a piston which moves along a fixed length cylinder, forcing a predetermined volume of liquid outside or inside the pipette.

There are two types of piston pipettes: the fixed volume type with a predetermined liquid volume known as *nominal volume* [Nv] and the variable volume type, which allows adjusting of the volume dispensed within a determined range depending on the pipette's specifications. Volume adjustment is achieved by modifying the range of the piston's movement inside the plunger. In variable volume pipettes, the nominal volume is the maximum volume the pipette can hold according to the manufacturer's specifications.

Fixed volume and variable volume pipettes can be subdivided into two types: A and B. Pipettes of the type A are named *air displacement pipettes* due to the fact that there is a volume of air between the head of the piston and the liquid in the cylinder (see pipette No. 1, Figure 51). Type B pipettes are called *positive displacement pipettes* or direct displacement pipettes as the piston is in direct contact with the liquid (see pipette No. 2). Figure 44 shows differences between these types of pipettes.

Air displacement pipettes have the advantage of presenting less risks of contamination when heavily used. However, they are not as precise as positive displacement pipettes when working with very small volumes of liquid due to the

compressibility of air. All piston pipettes have disposable tips for minimizing risks of contamination. It is recommended to exclusively use tips provided by the manufacturer or compatible with the specific pipette to guarantee their correct adjustment to the pipette's body as well as volumes dispensed. In order to facilitate identifying these volumes, some manufacturers have adopted a colour code which simplifies the identification of the volumes to be dispensed. The following table demonstrates this colour convention.

Table of pipette colour coding

Volume range in microlitres ( $\mu\text{l}$ )	Colour
0.1–2.5 $\mu\text{l}$	Black
0.5–10 $\mu\text{l}$	Grey
2.0–20 $\mu\text{l}$	Grey/Yellow
10–100 $\mu\text{l}$	Yellow
50–200 $\mu\text{l}$	Yellow
100–1000 $\mu\text{l}$	Blue
500–2500 $\mu\text{l}$	Red

## REQUIREMENTS FOR USE

To use a pipette, the laboratory must be suitably clean and well lit. The general conditions are the following:

1. Verify that room temperature is stable with an optimum temperature of 20 °C with a variation range of  $\pm 5$  °C (between 15 °C and 30 °C).
2. Confirm that the relative humidity is higher than 50 %. The pipettes and samples or liquid materials must be stabilized to the conditions of the laboratory. Typically it is recommended to equilibrate these in the laboratory two to three hours before the work is performed.
3. Avoid working with pipettes under direct sunlight.
4. Use the appropriate protective elements if working with toxic materials or those carrying a biological risk.

Figure 51. Types of pipettes

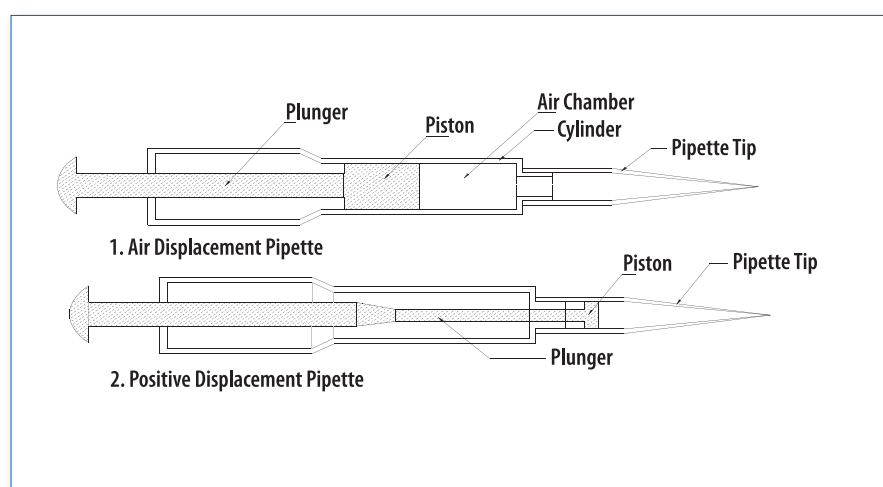

## USING THE PIPETTE

In order to obtain precise, exact and reliable results, it is necessary for pipette operators to know in detail correct pipetting procedures. This is achieved by training and detailed follow-up regarding the use of pipettes. The general outlines for the appropriate use of pipettes are as follows:

**Warning:** Before using a pipette, verify that it is correctly calibrated and suitable for the transfer of liquid volume to be performed.

### General recommendations

1. Verify that the pipette is in a vertical position to aspirate a liquid. The vertical position guarantees that there is no uncertainty due to minimal variation at the surface of the liquid.
2. Use the recommendation outlined by the manufacturer for the minimum immersion depth of the pipette's tip to aspirate liquids. The depths vary according to the pipette type and capacity. A general guide is shown in the following table<sup>1</sup>:

Table of tip immersion depth according to the pipette volume range

Volume range of the pipette (µl)	Depth of the immersion (mm)
1–100	2–3
100–1000	2–4
1 000–5000	2–5

<sup>1</sup> Blues, J., Bayliss, D., Buckley, M., *The calibration and use of piston pipette*, UK, National Physical Laboratory, Teddington, Middlesex, 2004, page. 6. (www.npl.co.uk)

3. Humidify tips of air displacement pipettes for better pipetting accuracy. To humidify the tip, draw working solution several times, dispensing its contents into the waste container. This reduces the possibility of air bubbles being aspirated when dense or hydrophobic liquids are aspirated. The process mentioned allows humidity to be homogeneous in the pipette's air chamber (area between the piston's head and the liquid's surface). Pre-humidifying is not necessary in pipette dispensing volumes lower than or equal to 10 µl. Neither is humidifying necessary for positive displacement pipettes.
4. After filling the pipette tip, remove any drop on the tip by gently sliding the pipette tip against the wall of the original tube. Absorbent material may be required to avoid touching the pipette's tip and taking necessary precautions in case the material shows any sign of contamination.
5. Dispense the liquid drawn by letting the tip touch the wall of the receiving tube. The pipette's tip must form an angle ranging between 30 and 45° with the tube at 8 to 10 mm above the surface of liquid.

### Correct pipetting technique

The following is a description of the general steps required when using a mechanical air displacement pipette. The operator must take into account specific recommendations of the manufacturer. This observation must also be respected when using electronically-controlled pipettes. The diagram in Figure 52 shows the description of the process.

Figure 52. Phases of pipette use

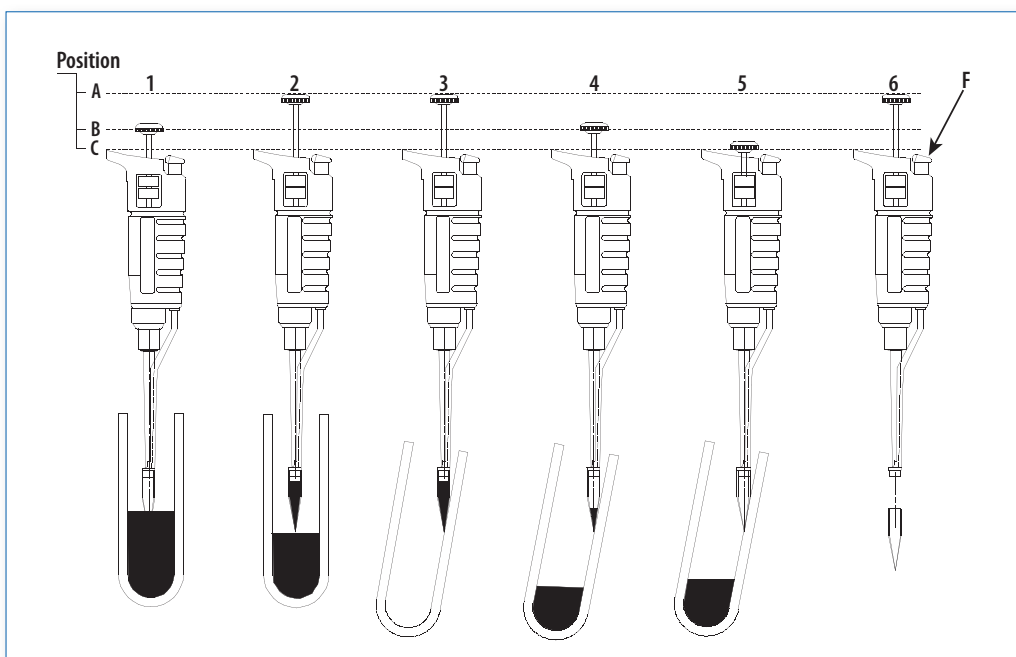

1. Place a new tip according to the pipette specifications on the pipette tip holder. Avoid contaminating the tip with other substances. Verify that it remains well adjusted.
2. Press the plunger gently until it reaches the first limit. Until this point, the tip of the pipette must not touch the liquid.
3. Put the extremity of the tip in the liquid. Verify the recommended depth included in table 2 or use the recommendation provided by the manufacturer. Confirm that the pipette is in a vertical position. This process corresponds to the position 1B (first to the left) in the figure.
4. Release the plunger gently for the pipette to aspirate the liquid (position 2A). Verify that the plunger is completely released. Wait at least two seconds before removing the pipette's tip from the liquid.
5. Place the pipette's tip against the wall of the receiving tube. Verify that the angle formed between the pipette's tip and its wall is between 30 and 45°. If the receiving tube already contains liquid, avoid the pipette's tip from being submerged (position 3A).
6. Dispense the contents of the pipette by pressing the plunger gently but firmly, until reaching the first limit (position 4B). At all times, maintain contact between the pipette's tip and the wall of the receiving container. Gently slide the tip against the inside wall at 8 to 10 mm from the tube edge to ensure that there are no drops of liquid left on the pipette tip.
7. Press the plunger gently until it reaches the second limit on the piston's path (position 5C). This expels any fraction of liquid still in the pipette's tip, by forcing out the air in the chamber through the opening of the tip. Keep the plunger pressed at the second limit while the pipette is removed from the receiving tube. Once the pipette is removed, gently release the plunger to the higher limit position.
8. Discard the pipette's tip. To do this, press the expulsion mechanism's button (position 6).

**Note:** If a variable volume pipette is used, the volume to be dispensed must first be selected. To do this, instructions indicated by the manufacturer must be followed. Normally the volume controls are found in the upper part of the pipette. It is necessary that the operator understands and learns to differentiate the scales.

## ROUTINE MAINTENANCE

General outlines of the required routine maintenance for mechanical pipettes are featured next. Specific maintenance must be carried out on the different models according to the instructions manuals provided by the manufacturers.

## Inspection:

### Frequency: Daily

Pipettes require frequent inspection in order to detect abnormal wear and tear or damage and/or to verify that they are in good working condition. Inspection must cover the following aspects:

1. Verify the integrity and adjustment of the mechanisms. These must move smoothly. The piston must move smoothly.
2. Confirm that the tip holder is not displaying distortions or signs of being worn out, as it is essential for the exactitude of measurements. Verify the adjustment of the tips.
3. Put on a tip and fill it with distilled water. The pipette must not show any leak.

## Cleaning and decontamination

1. Every day, verify that the pipette is clean. If dirt is detected, it must be cleaned using a suitable solvent or a mild detergent solution. Check the manufacturer's recommendation regarding the compatibility of the pipette with solvents to select the appropriate one.
2. Sterilize the pipette according to the manufacturer's indications. Some pipettes can be sterilized in an autoclave using a cycle of 121 °C for approximately 20 minutes. Some will need to be disassembled for the vapour to come into contact with their internal components<sup>1</sup>. Disassembly consists of liberating and unscrewing the central body of the pipette according to the procedures indicated by the manufacturer. To disassemble or assemble some pipettes, a set of tools (keys) provided by the manufacturers with the pipette at the time of sale must be used. After the sterilization cycle, the pipette must only be reassembled once at room temperature. Prior to assembly, it should be verified that the components are dry. Some manufacturers recommend sterilizing the pipette using a 60 % isopropanol solution and washing the components with distilled water, drying and assembling.
3. If a pipette has been used with harmful substances, it is the responsibility of the user to ensure that it is completely decontaminated before it is used in other procedures or removed from the laboratory. It is advisable to expeditiously prepare a report indicating its brand, model, serial number, contaminating substances and substances or procedures with which it was treated or cleaned.

<sup>1</sup> Pipettes which can be sterilized with vapour have a mark with such identification; the manufacturer supplies the requirements for disassembly.

## Maintenance

### Frequency: Bi-annually

A pipette used daily must be submitted to the following procedures for guaranteeing its correct functioning:

1. Disassemble the pipette. Follow the procedure described by the manufacturer in the user manual (the procedure varies depending on the brand and model). Normally, the main body of the pipette is disassembled from the tip ejector system unscrewing the body of the pipette from the cylinder.
2. Clean the O rings, the plunger and the inside of the cylinder before lubricating. If the internal components were contaminated accidentally, all the surfaces should be cleaned with a mild detergent and then with distilled water. If the O rings or gaskets need to be changed, replacement parts with the same characteristics as the original should be used. The type of ring or gasket varies depending on the pipette brand, type and model.

3. Lubricate the plunger and piston with silicone grease<sup>1</sup> specially developed for pipettes. Always use the lubricant recommended by the manufacturer. Remove any excessive lubricant with absorbent paper.
4. Assemble following the reverse process to that of disassembly.
5. Calibrate the pipette before use.

### Concepts of pipette calibration

Calibration of pipettes is done using standardized procedures.

The calibration method depends mainly on the volume the pipette handles. The smaller the volume range of the pipette, the more demanding and costly the calibration process is. A brief description of the gravimetric process used with pipettes dispensing volumes between 20 µl (microlitres) and 1 ml (millilitre) is explained in this chapter.

Figure 53. Disassembly of a pipette

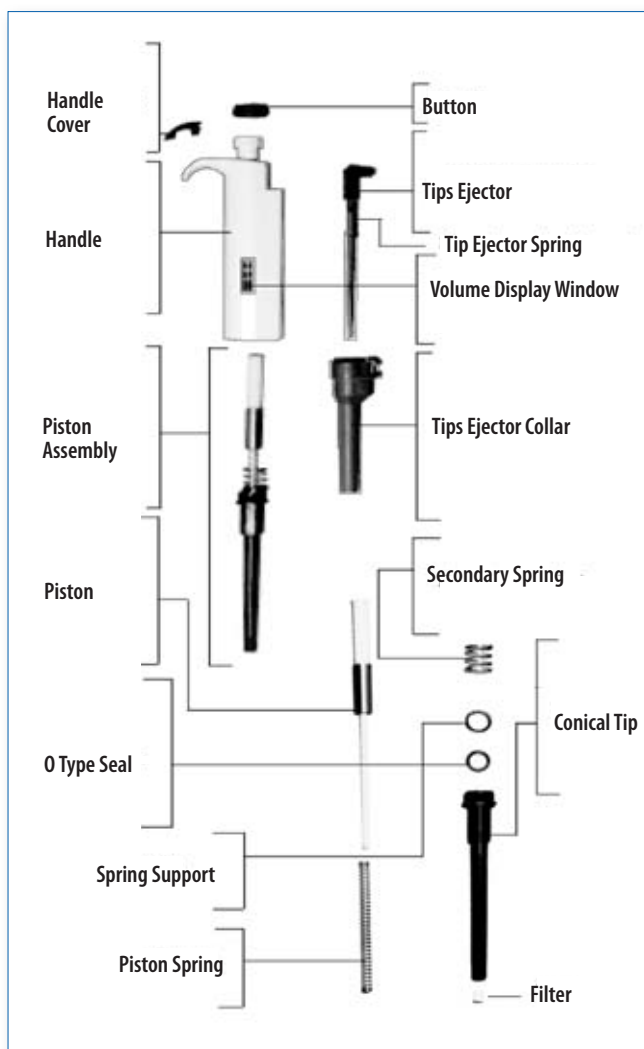

### Required materials and equipments<sup>2</sup>

1. Analytical balance.
2. Electronic thermometer with a 0.1 °C or greater resolution, of suitable temperature range with a submersible probe
3. Hygrometer with a standard uncertainty of 10 % or less.
4. Barometer with a standard uncertainty of 0.5 kPa or less.
5. Timer.
6. Micropipettes of various volumes.
7. Disposable tips of various volumes.
8. Flat bottom vials.
9. Bi- or tri-distilled degassed water.
10. Trained operator.

### Recommended Pipette Calibration Frequency (Quarterly)

#### Principle

The procedure is based on measuring the volume of a water sample from the mass of water dispensed by the pipette and dividing that mass by the water density. In practice, a group of measurements is done, to which corrections are applied to compensate for any variation due to non standard temperature and atmospheric pressure and to any significant evaporation during test.

<sup>1</sup> There are different specifications for silicone grease; therefore the grease recommended by the pipettes manufacturer must be used.

<sup>2</sup> The equipment used in pipette calibration must be certified by an accredited calibration laboratory.



This type of test allows the following:

1. To compare different types of pipettes to each other to detect if there are differences among them.
2. To check the precision and exactitude of a pipette.
3. To check the exactitude and precision of a batch of pipettes.
4. To check factors attributable to the use of one pipette by several users.

### Procedure<sup>1</sup>

The procedure explained next is valid for air displacement pipettes. It includes the following steps:

1. Install a new tip on the pipette.
2. Pipet distilled water and empty into the waste container. Repeat at least 5 times in order to stabilize the humidity of the air inside the pipette.
3. Add water to the weighing receptacle until the level of liquid reaches at least 3 mm.
4. Register the temperature of the water, environmental pressure and relative humidity.
5. Cover the weighing receptacle, if this applies.
6. Register the weight shown on the balance or press tab so that the reading is zero (0).
7. Fill the pipette with water from the storage container and dispense it into the weighing receptacle expelling all the water. This is done in the same way pipettes are used on a daily basis (see step 7 of the *Correct pipetting technique*).
8. Register the new weight detected by the balance.
9. Repeat steps 7 and 8 nine (9) additional times, recording the weight registered by the balance at the end of each cycle.
10. Register the temperature of the liquid inside the weighing receptacle at the end of the tenth cycle and measure the time elapsed since the measurements started.
11. Evaluate if evaporation has been significant (this is critical when working with pipettes of very small volumes). If this is the case, an additional period of time [Ta] equal to the time used during the ten measurements must be allowed to elapse, and when completed, a new reading has to be carried out.
12. The mass of water lost by evaporation in the additional time [Ta] is divided by the total number of samples analyzed (ten). This will give an indication of the average mass of liquid lost due to evaporation per cycle. This figure must be added to each of the mass readings.

### Calculations

Proceed as follows:

1. Calculate the mass of water dispensed by the pipette in each cycle. Subtract the reading registered at the end of the previous cycle to the reading registered in the current cycle. Repeat for all measurements. If appropriate, add the average mass corresponding to the calculated evaporation per cycle.

2. Convert each mass value to a volume at 20 °C, dividing the mass by the density of water adjusted to the mentioned temperature.

$$V_i = \frac{M_i}{D}$$

3. Calculate the average of the volumes calculated in step 2. (The sum of volumes, divided by the number of samples). Apply the adjustments per phenomenon such as the air pressure onto the mass (flotation). To accomplish this, multiply each mass by a correction factor [Z].

$$X = \sum V_i / n \times Z$$

4. Calculate the standard deviation of the sample.

$$SD = \sqrt{\frac{1}{n-1} \times \sum_{i=1}^n (X_i - X_{AV})^2}$$

5. Calculate the coefficient of variation.

$$[Cv]CV (\%) = \frac{S}{X_{AV}} \times 100$$

A table containing a summary of the mathematical formulae mentioned is shown next.

Table of mathematical formulae

$X = \sum V_i / n \times Z$	$[Cv]CV (\%) = \frac{S}{X_{AV}} \times 100$
$SD = \sqrt{\frac{1}{n-1} \times \sum_{i=1}^n (X_i - X_{AV})^2}$	$D\% = \frac{X_{AV} - X_{Nom}}{X_{Nom}}$
$E_s = X - V_n$	$V_i = \frac{M_i}{D}$
<b>Conventions:</b>	<b>Conventions:</b>
X = average volume SD = standard deviation Z = adjustment factor in (µl / mg) <sup>2</sup>	CV(%) = variation coefficient D(%) = error

<sup>1</sup> The procedure presented is a general guide. For complete details, consult the standards BS ES ISO 8655-6:2002 or current updates.

<sup>2</sup> The values Z depend on the temperature and pressure of distilled water. Refer to specialized publications such as the Standard BS EN ISO 8655-6:2002, Attachment A.

TROUBLESHOOTING TABLE		
PROBLEM	PROBABLE CAUSE	SOLUTION
The pipette displays leaks.	The tip is placed incorrectly on the pipette.	Install the tip according to the procedure indicated by the manufacturer.
	There are foreign bodies between the tip and the adjustment cone.	Clean the joint. Remove the tip and clean the adjustment cone. Install a new tip.
	There are foreign bodies between the piston and the O-ring in the cylinder.	Disassemble and clean the cylinder/piston set. Lubricate and assemble.
	There is insufficient lubricant in the piston and/or the O-ring.	Disassemble and lubricate adequately.
	The O-ring is twisted or damaged.	Replace the O-ring. Disassemble, clean, replace gasket, lubricate and assemble.
	The piston is contaminated.	Clean the piston and lightly lubricate.
	The lower cone is slack.	Adjust the lower cone.
There are visible drops inside the pipette's tip.	There is non-homogeneous humidification of the plastic wall.	Install a new tip on the pipette.
The pipette shows inaccuracies.	Incorrect operation of the pipette.	Check the pipetting technique and correct the detected errors.
	There are foreign bodies under the activation button.	Clean the button's assembly mount.
	The pipette tip is incorrectly mounted.	Check the fit of the pipette's tip. Install a different tip suitable for the pipette's specification.
	There is interference in the calibration.	Recalibrate according to standardized procedure. Check use procedure.
	The tip is contaminated.	Use a new tip.
The tip shows inaccuracies with determined liquids.	The calibration is inadequate.	Recalibrate the pipette using standardized procedure.
		Adjust the calibration if liquids of high viscosity are used.
The control button does not move smoothly or shows high resistance to its activation.	The piston is contaminated.	Clean and lightly lubricate.
	The gasket is contaminated.	Disassemble the pipette, clean all the gaskets, or replace them if necessary. Lightly lubricate.
	The piston is damaged.	Replace the piston and the piston's gaskets. Lightly lubricate.
	Solvent vapours have entered into the pipette.	Unscrew the central joint of the pipette. Ventilate, clean and lightly lubricate the piston.

## BASIC DEFINITIONS

**Coefficient of variation [%CV].** A statistical parameter representing the ratio of the standard deviation of a distribution to its mean.

**Density.** Relationship between a body's mass and the volume which it occupies. The average density of an object is equal to its total mass divided by its total volume. It is identified by the Greek letter  $\rho$ . In the International System of Units, density is measured in kilograms by cubic metres [ $\text{kg}/\text{m}^3$ ].

**Error (of a measurement).** A difference shown between the value measured and the correct value.

**Exactitude.** A concept related to errors shown in measurements. It is said that an instrument is exact when the value of a group of measurements are sufficiently close to the real value.

**Mass.** A physical property of the bodies related to the quantity of matter these contain, expressed in kilograms (kg). In physics, there are two quantities to which the name mass is given: gravitational mass which is a measure of the way a body interacts with the gravitational field (if the body's mass is small, the body experiences a weaker force than if its mass were greater) and the inertial mass, which is quantitative or numerical measure of a body's inertia, that is, of its resistance to being accelerated.

**Microgram [ $\mu\text{g}$ ].** A unit of weight equivalent to  $1 \times 10^{-6}$  grams (g).

**Microlitre [ $\mu\text{l}$ ].** A unit of capacity equivalent to  $1 \times 10^{-6}$  litres (l). One (1)  $\mu\text{l}$  of water weighing exactly one (1) mg and has a volume of  $1 \text{ mm}^3$ .

**Milligram [mg].** A unit of weight equivalent to  $1 \times 10^{-3}$  grams (g).

**Millilitre [ml].** A unit of capacity equivalent to  $1 \times 10^{-3}$  litres (l). One (1) ml of water weighing exactly (1) g and has a volume of  $1 \text{ cm}^3$ .

**Precision.** A concept related to errors shown in measurements. An instrument or method is precise when upon repeating a measurement in independent tests, the results obtained are similar.

**Range.** A difference between the maximum and minimum value which an instrument reads or measures.

**Standard deviation [SD].** Measure of the dispersion of a set of data from its mean. The more spread apart the data is, the higher the deviation. It is used as a statistical parameter for determining the global error of a sample set.

**Volume.** A quantity of physical space that a mass occupies. It is calculated by dividing the mass by its average density.

# Chapter 17



## Stirring Heating Plate

<b>GMDN Code</b>	36815
<b>ECRI Code</b>	16-287
<b>Denomination</b>	Heating Plates

The stirring heating plate or heated stirring heating plate has been developed to heat and mix fluids contained in laboratory receptacles such as flasks, test tubes and beakers.

### PHOTOGRAPH OF THE STIRRING HEATING PLATE



Photo courtesy of Cole-Parmer Instrument Co.

### OPERATION PRINCIPLES

Generally, the stirring heating plate has a flat surface on which are placed receptacles containing fluids to be heated and agitated. Its surface is made of good thermal conductors such as aluminium [Al] or ceramic materials. Some heating plates exclusively use radiation sources such as infrared (infrared light) for heating. Stirring hot plates have a heating element (an electrical resistor), a control system (on and off, temperature control, agitation control and its respective motor). The motors used in these types of instruments are generally of single phase induction named shaded pole<sup>1</sup>. The speed range depends on the number of poles and the frequency of the feed voltage.

#### Temperature:

Room Temperature up to approximately 500 °C.

#### Rotation speed:

From 60 RPM up to approximately 1200 RPM.

### CONTROLS OF THE STIRRING HEATING PLATE

The diagram in Figure 54 includes a typical control found on a stirring heating plate. The diagram shown corresponds to a microprocessor-regulated heating plate which is found in most modern equipment.

Figure 54. Stirring heating plate controls

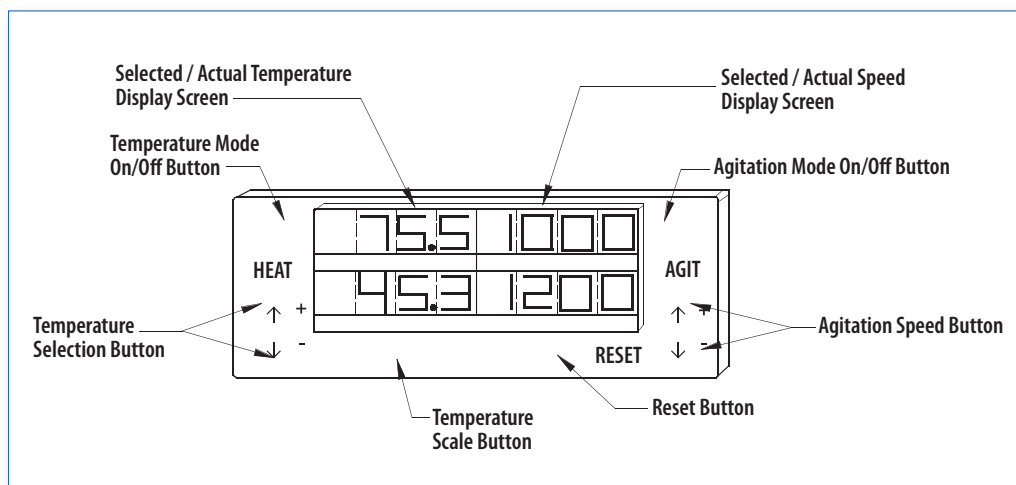

<sup>1</sup> The power of these motors is approximately 1/20 hp; these are characterized by having a low torque and being low in price. They are called *shaded pole induction motors*.



The control has buttons for selecting the temperature and the stirring heating plate's speed. These can be used independently or in combination. To select the parameters, only the corresponding control button needs to be activated and the temperature and speed selected, whichever is required.

### INSTALLATION REQUIREMENTS

The stirring heating plate needs to be connected to an electrical outlet in good condition with a ground pole. The outlet must be compatible with the equipment and in compliance with the national and international electrical standards. In general, stirring heating plates operate with voltages of 120 V/60 Hz, or 230 V/50-60 Hz.

For normal operation it is required to have an appropriately levelled surface with sufficient resistance to support the weight of the stirring heating plate together with that of the receptacles and liquids these may contain.

### OPERATION OF THE STIRRING HEATING PLATE

#### Precautions

1. Always connect the stirring heating plate to an electrical outlet in good condition which has a ground pole.
2. Disconnect the equipment before carrying out any maintenance routine.
3. Avoid using the equipment in the presence of combustible or flammable materials. Avoid using equipment in environments with corrosive vapours.
4. Carefully check if substances have a low ignition point (*Flash point*). It could start a fire or an explosion if the vapour touches the surface of the heater at this temperature.
5. If working with flammable liquids, use personal protective elements: gloves and protective eyeglasses.
6. Take into account that the surface of the equipment can stay hot for a long period after being turned off or disconnected.
7. Avoid placing on the heating surface:
  - a) Metallic laminates
  - b) Materials with insulating properties
  - c) Low melting point glassware
8. Maintain a free space around the equipment to facilitate its connection and placing materials or substances needed with the equipment. Some manufacturers recommend a free space of approximately 15 cm.
9. Avoid placing combustible materials near the equipment.
10. Avoid using containers whose weight exceeds the capacity indicated by the manufacturer.

### ROUTINE MAINTENANCE

The stirring heating plate is designed to work under normal conditions and requires minimal maintenance. This equipment should work without problems for several years if well installed and operated. This document presents the general routine maintenance recommended by manufacturers. Specialized procedures must be done carefully following manufacturers' recommendations.

#### Cleaning

##### Frequency: Monthly

1. Clean the equipment in a vertical position to avoid cleaning agents from reaching internal components.
2. Use a mild detergent. Apply to the external surfaces using a piece of cloth of similar texture to that of a handkerchief.
3. Verify that the equipment is completely dry before connecting it again.

#### Replacement of the ceramic surface

##### Frequency: Whenever necessary

General recommendations applicable to the substitution of the ceramic surface are presented next.

1. Verify that the heating plate is disconnected and cold. This prevents the risk of electric shock or burns.
2. Handle the equipment with extreme care since a broken ceramic surface has dangerously sharp edges.
3. Place the unit with its heating surface facing downwards.
4. Remove the screws which secure the lower cover and remove it.
5. Locate and disconnect the cables which feed the electrical resistors (in models with such elements).
6. Disconnect the cables connecting the equipment's control and the resistors.
7. Remove the screws which fasten the upper cover to the base. Verify that they do not affect the connection to the heating resistors.
8. Place the new ceramic surface in its appropriate location.
9. Observe how the safety devices of the damaged ceramic cover are positioned. Remove the safety devices and place the heating and insulating elements inside the new surface, maintaining the same alignment and distribution of the original. Put the new safety devices back.
10. Reconnect the components in the reverse order to that described above.

**Replacement of fuses**

**Frequency: Whenever necessary**

If the stirring heating plate is connected and the main switch is in the on position but it is not warming up, it is possible that a fuse needs to be changed. The following is the process for changing the fuse:

1. Place the main switch in the off position and disconnect the electrical feed cable.
2. Remove the top of the fuse compartment with a flat screwdriver.
3. Replace the fuse by a new one with the same specifications as the original.
4. Replace the fuse's compartment cover.

TROUBLESHOOTING TABLE		
PROBLEM	PROBABLE CAUSE	SOLUTION
There is no electrical power.	There is a failure in the protection fuse.	Substitute the protection fuse.
	There is a failure in the electrical connection feeding the equipment.	Check the state of the electrical connection.
	The equipment is disconnected from the electrical feed outlet.	Connect the equipment to the electrical outlet.
	The electrical feed cable is defective.	Substitute the electrical feed cable.
The plate shows no sign of warming up.	The heating function has not been selected.	Activate the heating function on the control panel.
	The heating resistor is out of service.	Substitute the heating resistor. Install replacement parts with the same characteristics as the original.
There is no rotation.	The rotation function has not been selected.	Activate the rotation control on the control panel.

**BASIC DEFINITIONS**

**Erlenmeyer.** A glass container used in laboratories to put or measure substances.

**Shaded pole motor.** An induction motor used in small machines. It is characterized by having a bobbin (squirrel cage rotor) requiring a rotating magnetic field for starting. Each field pole has a shading coil (copper ring) which induces currents causing the magnetic flow to become imbalanced in relation to the flow in the other portion, producing a torque in the rotor. These motors are low cost and low efficiency. Their speed can be calculated by means of the equation:

$$n(\text{rpm}) = \frac{120 f}{p}$$

Where:

[n] = synchronous speed in revolutions per minute

[f] = frequency of voltage applied

[p] = number of poles in the stator

A diagram is included showing the inner part of the electrical circuits.

**Figure 55. Induction motor**

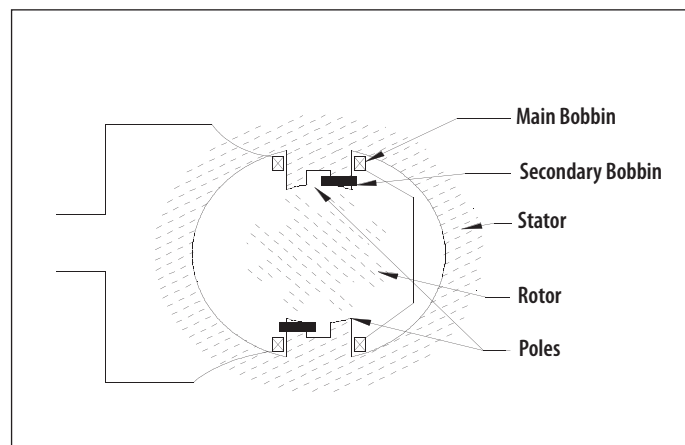

**Ignition point.** The temperature at which molecules of a substance react with oxygen in the air, initiating combustion. This temperature is called *Flash Point*.



# Chapter 18



## Refrigerators and Freezers

<b>GMDN Code</b>	13315	13315	17157	35486	40513	15145
<b>ECRI Code</b>	13-315	15-170	17-157	15-171	22065	15-145
<b>Denomination</b>	Refrigerators	Biological refrigerators	Laboratory refrigerators	Blood bank refrigerators	Freezer, laboratory, ultralow	Freezer, laboratory

### REFRIGERATORS AND FREEZERS

Refrigerators and freezers are among the most important pieces of equipment in laboratories. They maintain a temperature controlled (refrigerated) environment for various fluids and substances. At lower temperatures, less chemical and biological activity is present so that fluids and substances are better preserved. To achieve this, the temperature of the refrigerated storage unit needs to be lower than ambient temperature. In the laboratory, different kinds of refrigerators and freezers are used. They can be grouped by temperature ranges:

- o Conservation refrigerators in the range of 2 to 8 °C.
- o Low temperature freezers in the range of -15 to -35 °C.
- o Ultralow temperature freezers in the range of -60 to -86 °C.

A unit with appropriate functions must be selected depending on the activities carried out in the laboratory. For example: if it is necessary to conserve whole blood, it will be appropriate to use a Blood bank refrigerator which provides temperatures between 2 and 8 °C. On the other hand, if it is required to conserve a particular viral or microbial stock, an ultralow temperature freezer is required. Refrigerators and freezers are essential for conserving biological substances and reagents. This chapter deals with the operational and maintenance aspects of the conservation refrigerators and ultralow temperature freezers.

### PHOTOGRAPH OF A REFRIGERATED STORAGE UNIT



Photo courtesy of Cole-Parmer Instrument Co.





### PURPOSE OF REFRIGERATED STORAGE UNITS

Refrigerators and freezers are used for the conservation of blood and its derivatives, biological liquids and tissues, reagents, chemicals, and stocks. In general, the higher the temperature the more chemical and biological activity is present. By reducing temperature, one can control the effects on the composition and structure of substances to be preserved. In the laboratory, systems of refrigeration are used for conserving substances such as reagents and biological elements which would otherwise decompose or lose their properties. Refrigeration, as a technique offers conditions which renders possible the conservation of elements such as blood and its derivatives needed for diagnosis, surveillance and for providing health services. It is possible to achieve extremely low temperature ranges, such as those used for master stocks conservation ( $-86\text{ }^{\circ}\text{C}$ ) or temperatures within the range of  $2$  and  $8\text{ }^{\circ}\text{C}$ , which is sufficient for conserving reagents and diverse biological products.

### OPERATION PRINCIPLES

Refrigerators and freezers function according to laws of physics regulating the energy transfer where temperature differences exist. From the second law of thermodynamics it is known that, if thermal energy needs to be transferred from a point with low temperature to another with high temperature, a mechanical task needs to be carried out. Modern refrigerators and freezers are thermal systems which function mainly using a cycle called *compression*, where refrigerant gas with special properties achieving heat transference is used. This chapter focuses on explaining how refrigerators and freezers using compression operate.

### Refrigeration circuit

The basic circuit shown in Figure 56 demonstrates how a refrigerator functions. On the left side it is possible to distinguish the following components: evaporator, condenser, compressor, expansion valve, filter and interconnection tubing. Within each one of these components, refrigerant gas circulates.

On the right side of the figure is shown a graph of temperature  $[T]$  versus entropy  $[S]$ , which demonstrates the functioning of an ideal<sup>1</sup> refrigeration cycle. The numbers on the basic diagram on the left show points of the adiabatic processes (compression  $[1-2]$  and choking  $[3-4]$ ) and the processes involved in heat transference (in the evaporator – refrigerated environment  $[4-1]$ , in the condenser  $[2-3]$  on the exterior). The complete cycle is described as the sequence of processes  $[1-2-3-4-1]$ .

**Evaporator.** Contains a network of channels through which the refrigerant gas circulates. In the evaporator, a process of heat transference  $[Q]$  occurs at a constant pressure. In order for the refrigeration process to occur, the environment to be refrigerated must be surrounded by a system of thermal isolation. This is to prevent thermal energy from entering the evaporator's zone of influence at the same rate as the refrigerant gas absorbs it. The refrigerant gas enters into a liquid phase in the evaporator by point  $[4]$  (ideal) or  $[4']$  (real) and while it passes through the network of evaporator channels, it absorbs heat  $[Q]$  and progressively transforms into vapour. When the refrigerant gas reaches point  $[1]$ , it is under the form of vapour. It is then suctioned by the compressor through a tube or line.

<sup>1</sup> The real cycle differs from the ideal cycle by some irreversible processes not indicated in the graph for the sake of clarity and simplicity.

Figure 56. Refrigeration circuit

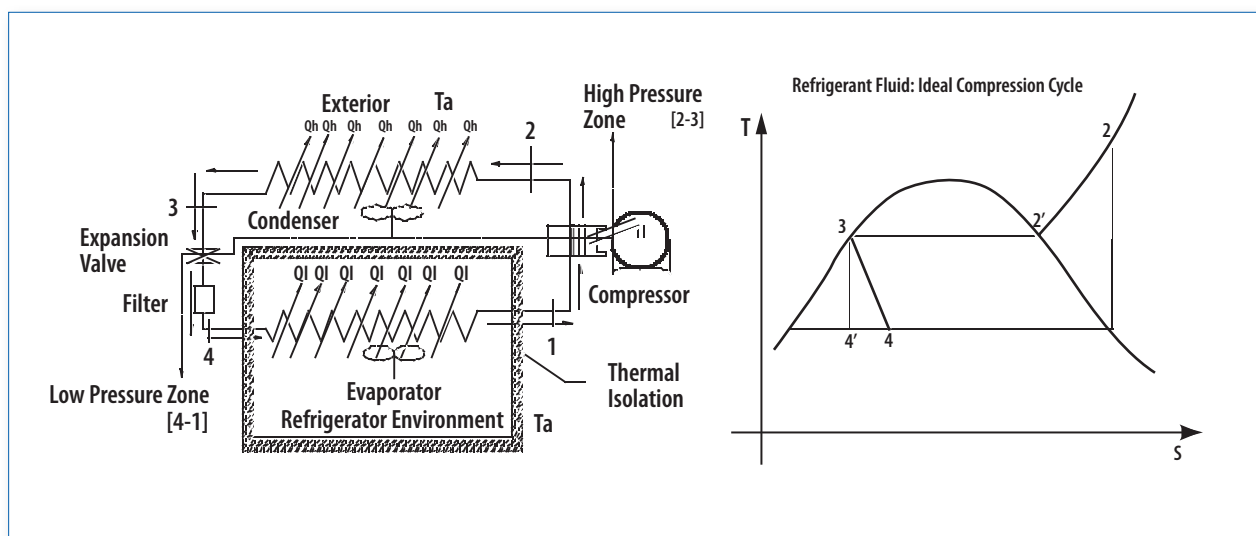

**Compressor.** Usually propelled by an electric motor, the compressor suctions the vaporized refrigerant from the evaporator (saturated) at low pressure and by means of a piston or set of pistons, exercises a process of reversible adiabatic compression on it (without heat transfer) between points [1-2]. Upon being discharged from the compressor, the vapour is hot as a result of the compression process and is delivered to the condenser in point [2].

**Condenser.** Similar device to the evaporator, which has a network of channels through which the refrigerant gas circulates. As the temperature of the refrigerant is higher than ambient temperature [Ta], a heat transference process [Qh] is produced from the refrigerant to the environment at constant pressure. To facilitate heat transference, the condenser tubes have thin fins which increase the transfer surface. As heat continues to be lost [Qh] as a result of the process of transference, the refrigerant returns to its liquid phase until it reaches point [3] as saturated liquid where it enters the expansion valve.

**Expansion valve.** Allowing the refrigerant to flow in a controlled manner, the valve exercises a resistance on the passage of the refrigerant to avoid any heat transference by an adiabatic process. As a result, the pressure in the valve is reduced in a drastic way in point [4]. A filter is generally installed at the exit of the expansion valve. Some manufacturers replace the expansion valve by a capillary tube which has an equivalent restrictive effect on the passage of the cooling fluid.

**Filter.** Retains humidity and impurities which may be present in the refrigerant. At the back of the filter, the system is connected again to the evaporator at point [4] and the cycle described is repeated.

**Liquid collector.** Sometimes placed by manufacturers before the refrigerant enters the compressor. Its purpose is to retain any portion of that fluid in liquid phase to guarantee that only vaporized refrigerant gas enters the compressor (not shown in the refrigeration diagram).

**Thermal insulation.** Set of materials with the property of slowing heat transference. Its function consists of preventing thermal energy from the environment to reach the refrigeration area at the same rate as the system extracts the internal thermal energy. All refrigeration equipment has adequate thermal isolation for this purpose. Among the most commonly used insulation materials are polyurethane foam and glass wool. Similarly, it is customary to manufacture interior surfaces in materials such as ABS plastic.

**Service valves.** Valves used for loading the refrigeration circuit with refrigerant gas. By means of these valves, the draining and filling systems are connected so that the

refrigerated storage unit operates according to specifications established by the manufacturer. Only the manufacturer and specialized technical personnel have access to these valves (not indicated in the refrigeration diagram).

**Thermal protector.** This is a protective device which is activated and disconnects the compressor in case overloads affecting the bobbins in the compressor's field occur (It pertains to the electrical system and is not indicated in the refrigeration system's diagram).

**Note:** The evaporator, as well as the condenser are made of materials with good thermal conduction properties such as aluminium [Al] and copper [Cu]. To improve heat transference, ventilation systems which induce forced convection processes have been incorporated. To attain the different temperatures (refrigeration) required in laboratories or in the industry, manufacturers have developed diverse designs and refrigerants for the targeted results.

## INSTALLATION REQUIREMENTS

For their functioning refrigerators and freezers require the following precautions:

1. An electrical connection with a ground pole appropriate to the voltage and frequency of the equipment. In general depending on their capacity, refrigerators and freezers can be obtained in versions with 115 V, 60 Hz and 220-240 V, 50 Hz. Electrical connections complying with international and national electric standards used in the laboratory must be anticipated.
2. If more than one unit installed depend on the same electrical circuit, it must be verified that the capacity (electrical power) and safety devices are adequate for supplying the amount of power required by these units.
3. Directly connect the unit to the electrical outlet. Never connect a unit to an overloaded electrical outlet or one with voltage deficiencies. Avoid the use of electrical extensions. The electrical outlet must not be more than 2 m from the unit.
4. Install the unit on a levelled surface, leaving free space around the equipment. Refrigerators and freezers have a levelling system at their base which allows them to adjust to small differences in level of the floor. It is customary to leave a free space of 15 cm at the sides and at the back of the unit to facilitate ventilation of the condenser.
5. Avoid installing the unit under direct sunlight or near a heat source such as radiators or heaters. Remember that the greater the difference in temperature is between the environment and the condenser, the more efficient will the heat transference be.

## REFRIGERATOR CONTROL CIRCUIT

The scheme in Figure 57 is a typical control circuit installed in refrigerators and freezers. Its purpose is to give an idea of how their diverse subsystems are interrelated. The control circuit of each model varies according to the characteristics incorporated by the manufacturer.

The following are featured as central components:

1. The main switch. It energizes the refrigerator.
2. The door switch. It turns on the light when the door is opened.
3. The compressor.
4. The evaporator's ventilators.
5. The defrosting subsystem. The switch, resistors, temporizer (5, 5', 5'', 5''', 5''').
6. The resistor subsystem for defrosting or maintaining the equipment's components free from ice.
7. The thermostat.

## REFRIGERATOR OPERATION

### Conservation refrigerators

The operation of conservation refrigerators is generally very simple. Each manufacturer gives basic recommendations. Some of these are highlighted below.

1. Connect the refrigerator's electrical feed cable to an electrical outlet equipped with a ground pole and the capacity to supply voltage at the required power.
2. Activate the on switch. Some manufacturers place key switches on refrigerators. Wait for the refrigerator to reach the operating temperature before storing any product. The manufacturers adjust the temperature of refrigerators at approximately 4 °C.
3. Select the temperature at which the alarm must be activated. Follow the instructions provided by the manufacturer.
4. Load the refrigerator according to the capacity established by the manufacturer.

Figure 57. Control circuit of the refrigerator

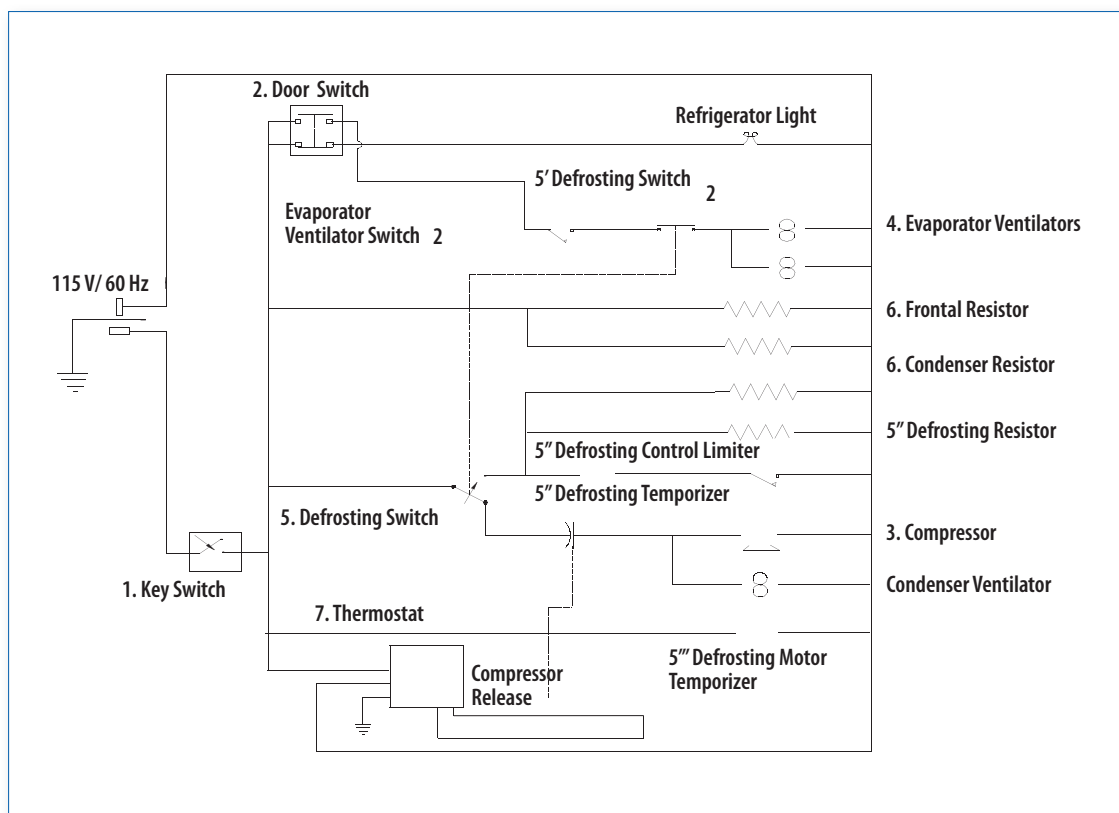

5. Distribute the load homogeneously inside the refrigerator. The temperature uniformity depends on the free circulation of air within the refrigerator.
6. Avoid opening the door for long periods of time in order to prevent thermal energy and humidity (from the air) from entering into the refrigerated environment. This forms ice and increases the working temperature of the refrigeration system. Open only for placing or removing stored elements.

**Conservation refrigerator controls**

A diagram of a recently developed control for conservation refrigerators (e.g. a Blood bank refrigerator) is shown in Figure 58.

The following controls can be seen in the diagram:

1. A main switch, activated by a key
2. Open door, low battery and abnormal technical condition indicators
3. Buttons for adjusting parameters
4. Display screen

**REFRIGERATOR ROUTINE MAINTENANCE**

Refrigerators are generally not very demanding from a maintenance perspective, although demanding with regards to the quality of the electrical feed systems. If connected to good quality electrical circuits and good ventilation flows around the unit, they can function for years without specialized technical service. The refrigeration circuit is sealed during manufacturing and does not have components requiring routine maintenance. The most common maintenance routines are described next. Consult

WHO’s *Manual on management, maintenance and use of cold chain equipment, 2005*, for care and preventive maintenance schedules specific to Blood bank refrigerators, plasma freezers and walk-in refrigerators and freezers used in the blood cold chain.

**Cleaning the interior**

**Frequency: Every quarter**

1. Verify that the refrigerator’s inner shelves are clean. These are generally made of rust proof metallic mesh. Before cleaning, any material which can interfere must be removed from the refrigerator. Move the empty shelves towards the front. Dampen a piece of cloth with a mild detergent and apply by rubbing surfaces gently. Dry and place in their original position.
2. If the refrigerator has drawers, cleaning is done the same way. Empty the drawers and dismount from the adjustment devices. Remove them from the refrigerator.
3. Once the shelves and drawers are dismounted, clean the interior walls of the refrigerator, using a mild detergent. Dry before mounting the internal accessories.
4. Apply a mild detergent with a damp piece of cloth to the drawers. Rub carefully. Dry the drawers and put them back on their mounts in the refrigerator.

**Warning:** Avoid using steel wool or other abrasive materials for cleaning the shelves and drawers. Avoid using gasoline, naphtha or thinners, as these damage the plastic, the packing or the paint on the surfaces.

**Figure 58. Blood bank refrigerator controls**

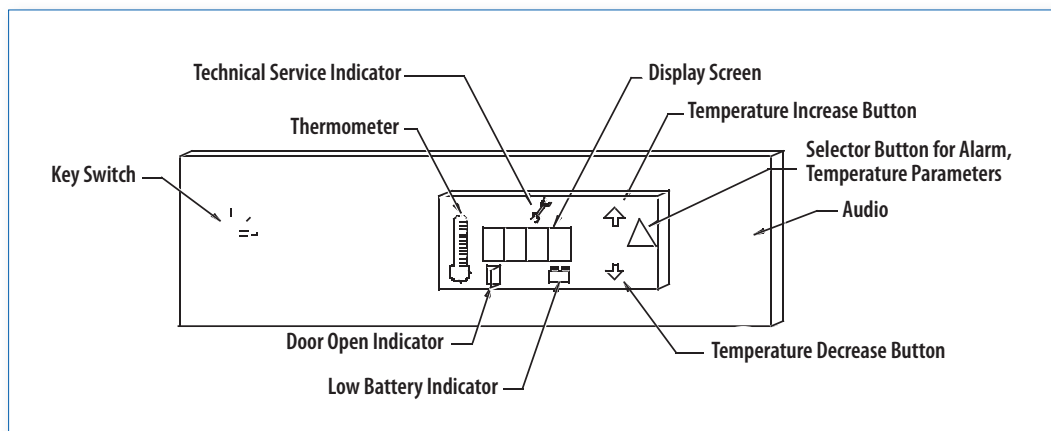

### Cleaning of the condenser

#### **Frequency: Every six months**

1. Disconnect the electrical feed cable.
2. Verify the position of the condenser. Manufacturers usually place it at the lower back of the equipment. In some refrigerators, it is installed on the top part.
3. Remove the condenser's protective grids and the protective filter (not all manufacturers provide a filter).
4. Remove the dust and grime deposited on the surface of the condenser. Use an aspirator equipped with a suction brush. Run it over the entire surface of the condenser to remove grime or accumulated dust. Verify that the tubes' surfaces as well as those of the heat conducting wings are clean. Vacuum the filter as well (if present).
5. Replace the cover.
6. Connect the refrigerator to the electrical connection.

**Warning:** If the condenser is not clean, this will interfere with the heat transference process and the refrigerator could "heat" or function at temperatures different than selected.

### The door gasket verification

#### **Frequency: Quarterly**

The door gasket is a component which must stay in a good condition for the unit to work correctly. To verify its condition, one must proceed according to the following steps:

1. Open the door.
2. Insert a strip of paper of about 5 cm in width between the door gasket and the edge of the refrigerator's body where the gasket is housed.
3. Close the door.
4. Pull the paper gently from the exterior. The paper must put up resistance when being moved outwards. If the paper can be moved without resistance, the gasket must be substituted. Perform this procedure on 10 cm of gasket at a time around the entire gasket housing.

**Warning:** A door gasket in bad condition produces various problems in the functioning of cooling units:

1. It allows humidity to enter which condenses and freezes inside the evaporator.
2. It increases the time needed by the compressor for maintaining the selected temperature.
3. It affects the storage temperature.
4. It increases the operational costs.

### Defrosting

#### **Frequency: Every six months**

Many modern freezers have automatic cycles for defrosting the evaporator in order to avoid frost accumulation. Normally, these cycles are done with a set of electrical resistors which rapidly eliminate the frost present. Some models do not have defrosting cycles and the process is done manually on a scheduled basis. The following are the recommended procedures for defrosting.

1. Verify that the thickness of the frost is more than 8 mm.
2. Remove the contents of the compartments.
3. Disconnect the freezer.
4. Leave the door open.
5. Remove the water while it is accumulating in the compartments. Use a sponge or a piece of absorbent cloth.
6. Place a towel to avoid the melting ice from wetting the front and interior part of the refrigerator.

**Warning:** Never use sharp elements to remove ice or frost from the evaporator. Such an action can perforate the wall of the evaporator and allow the refrigerant gas to escape causing a serious defect which can only be repaired by a specialist.

TROUBLESHOOTING TABLE		
PROBLEM	PROBABLE CAUSE	SOLUTION
The unit is not functioning.	Blown fuse.	Check fuse.
	The equipment is disconnected.	Verify the unit's connection.
	There is no or low electricity in the feed circuit.	Test the electrical connection. Verify the main switch (breaker).
The freezer is functioning continuously but is not cooling.	The thermostat is adjusted too high.	Confirm the adjustment of the thermostat. Adjust the thermostat to a lower temperature.
	The unit contains excessive frost.	Defrost the unit.
The unit is showing fluctuations in temperature.	The temperature control is not calibrated.	Calibrate the operational temperature according to the procedure defined by the manufacturer.
	The condenser is dirty.	Clean the condenser according to the procedure cited in the maintenance routines.
The unit shows a high temperature.	The door is open.	Verify that the door is well adjusted and closed.
	Poor door seal.	Level cabinet and adjust door seal or replace gasket.
	There is a defect in the electrical feed.	Confirm that the electrical connection functions correctly.
	A warm load (liquids or solids) was placed inside the unit.	Wait for the unit to cool the load.
	The compressor is not functioning.	Verify the functioning of the compressor. Test to see if one of the alarms is on.
	The compressor is functioning but there is no ice in the evaporator.	Verify if the evaporator's ventilators are functioning.
	The compressor is functioning, but there is no ice in the evaporator and the evaporator's ventilators are functioning well.	A complete verification of the refrigeration system is required. Call in the specialized service technician.
	Low refrigerant gas level.	Call in the specialized service technician.
Upon operating the unit, noises similar to clicking sounds can be heard.	The compressor's thermal protector has been disconnected.	Verify that the feed voltage is correct.
Noisy operation.	Floor not stable or cabinet not levelled.	Move to an adequate floor area or adjust casters as appropriate.
	Drip tray vibrating.	Adjust tray or cushion it.
	The cooling fan hitting cover or compressor is loose.	Call in the specialized service technician.
The compressor runs continuously.	Not enough air circulation around the unit.	Move the unit to provide with sufficient clearance. Relocate if necessary.
	Faulty thermostat.	Call in the specialized service technician.
	Poor door seal.	Check seals and adjust.
	Room too warm.	Ventilate the room appropriately.
	The door is being opened too often or is not closed.	Restrict door opening or close door.
	The light switch is defective.	Check if light goes out after the door is shut.

## OPERATION OF ULTRALOW FREEZERS

### Ultralow temperature freezers

Operation of ultralow temperature freezers implies following a procedure recommended by their manufacturers to achieve the conditions stipulated for the equipment. The recommendations common to any ultralow freezer are highlighted next:

1. Connect the unit to an electrical outlet with a ground pole exclusively dedicated to the unit. This outlet must be in good working condition and appropriate for the electrical power required for the unit. It must also be in compliance with the national and international electrical standards. The voltage must not vary by more than +10 % or -5 % from the voltage specification on the equipment. There are units which require power of approximately 12 kW. It is then essential to have an electrical connection which is of a suitable size for such loads.
2. Select a location which has a firm and levelled floor (in all directions). It should be well ventilated and away from direct sunlight or heat sources. Some manufacturers stipulate that suitable ambient temperature is between 10 °C and 32 °C. The free space at the sides and back must be at least 15 cm. The door must open freely at an angle of 90°. Normally, manufacturers include additional devices at its base on the support wheels for levelling the unit.

### TURNING THE UNIT ON

In order to understand the freezer's operational procedures, a diagram of a control panel similar to those used in such units is presented. The diagram in Figure 59 is generic: differences in the controls used by the various manufacturers will certainly be encountered. Included next are recommendations common to all refrigerators.

### Procedures

1. Connect the electrical feed cable to the electrical supply outlet.
2. Turn the key to the on position. The screen must be illuminated indicating the temperature of the cabinet. A light transmitting diode display will indicate that the unit is energized. This action will start the compressor, ventilators of the evaporator and the condenser.
3. Select the unit's operational temperature. In general, various buttons are activated simultaneously; the button corresponding to the temperature control and those to adjust the temperature. Once the desired temperature is selected, the controls are released. The screen will show the operational temperature selected. Wait a suitable time for the unit to reach the selected temperature.
4. Select the limit temperatures which will activate the alarms. These temperatures do not generally differ by more than 10 % from the operational temperature. In general, the alarms are adjusted when the unit has reached a temperature near its operational point. The procedure consists of activating the alarms' control and selecting higher and lower temperature limits so that the alarm is activated if these are exceeded. The manufacturer's recommended procedure must be followed. Usually, the control has a button which allows the alarms to be deactivated and also the option to test their functioning.
5. Ultralow temperature units have another series of alarms which warn the operators regarding the occurrence of events which can affect the adequate functioning of the unit. Among these are the following:
  - A flaw in the electric feed.
  - Low voltage.
  - Excessive room temperature.
  - The lower temperature limit is exceeded.

Figure 59. Ultralow freezer temperature control

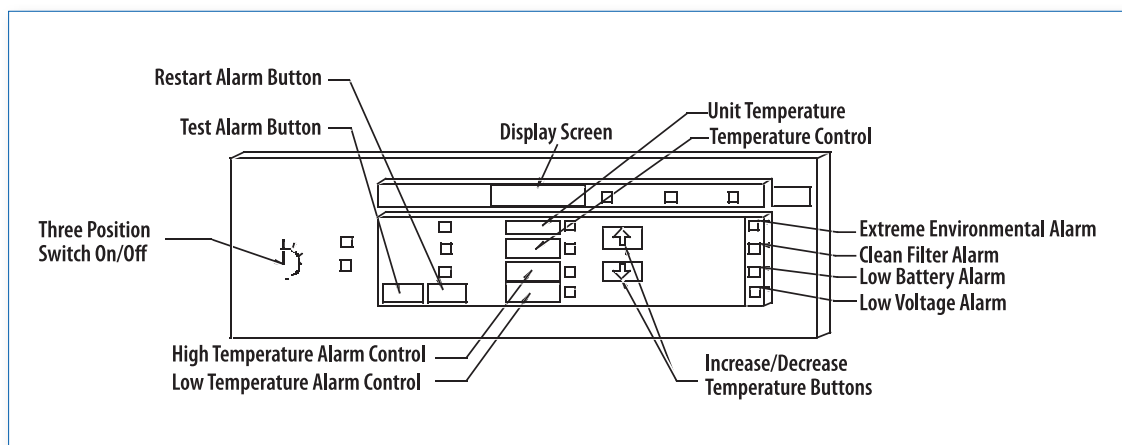

## ROUTINE MAINTENANCE

The maintenance routines of the ultralow temperature freezers are focused on the following elements described below. Consult WHO's *Manual on management, maintenance and use of cold chain equipment, 2005*, for care and preventive maintenance schedules specific to plasma freezers and walk-in freezers used in the blood cold chain.

### Cleaning of the condenser

#### **Frequency: Every six months**

1. Remove the protective grid.
2. Remove and clean the filter. If too obstructed, substitute by a new one with the same characteristics as the original.
3. Verify the functioning of the ventilator.
4. Vacuum the condenser and its diffusive fins.
5. Reinstall the protective grid and the filter.

**Warning:** A dirty condenser prevents normal heat transference causing the unit to warm up or exceed the selected temperature limits.

### Integrity of the door gasket

#### **Frequency: Recommended quarterly**

It is recommended that periodically, the integrity of the door gasket be verified. It must remain in good condition and not display cracks, punctures or tears.

## Defrosting

### **Frequency: Recommended every six months**

Whenever it is necessary to defrost the unit, it must be conducted in the following manner:

1. Transfer the products kept frozen to another unit with the same operational characteristics.
2. Turn off the unit and allow its interior to reach room temperature.
3. Remove the ice and water accumulated inside the unit.
4. If strange odours emanate, wash the inside of the unit with sodium bicarbonate and warm water.
5. Clean the exterior with a mild detergent, dry and then apply a protective wax if appropriate.

**Warning:** Never use sharp elements for removing ice or frost from the evaporator. Such an action can perforate the wall of the evaporator allowing the refrigerant gas to escape, dangerous for the operator and causing a serious damage which can only be repaired by a specialized repair shop.

### Maintenance of the alarm system battery

#### **Frequency: Approximately every two to three years**

The alarm system battery must be changed once worn out. To substitute it, proceed as described next:

1. Remove the front cover. In general, the battery (batteries) is (are) located immediately behind the front cover.
2. Disconnect the connection terminals.
3. Remove the worn out battery.
4. Install a battery with the same characteristics as the original.
5. Connect the terminals.
6. Replace the cover.



TROUBLESHOOTING TABLE		
PROBLEM	PROBABLE CAUSE	SOLUTION
The low voltage indicator is on.	There is inadequate voltage in the electrical feed outlet.	Verify the feed voltage. Test the connection and its protective systems.
The dirty filter indicator is on.	Verify the cleanliness of the filter.	Clean the condenser's protection filter. If it is saturated with grime, substitute it for another with the same characteristics as the original.
The low battery indicator is on.	The battery is worn out.	Substitute with a battery of same specifications as the original.
The unit is not functioning.	The equipment is disconnected.	Connect the equipment to the electrical feed outlet.
	The fuse is burnt out.	Substitute with a fuse of same characteristics as the original.
The unit functions in a continuous manner.	The operating temperature selected is very low.	Increase the temperature selected.
The unit functions in a continuous manner without getting cold.	The condenser is dirty.	Clean the condenser.
	There is inadequate ventilation.	Verify and correct the ventilation.
	There is an ice build-up affecting the insulation.	Defrost the unit. Call in the specialized service technician if the problem is not resolved.
Rapid frost accumulation on the evaporator.	Leaking door gasket.	Adjust door hinges. Call in the specialized service technician if the problem persists.
The door on the freezer compartment is shut frozen.	Faulty door seal heater.	Call in the specialized service technician.
Noisy operation.	Floor not firm or cabinet not level.	Move to sound floor area or adjust casters as appropriate.
	Drip tray vibrating.	Adjust tray or cushion it.
	The cooling fan hitting cover or compressor is loose.	Call in the specialized service technician.
The compressor runs continuously.	Not enough air circulation around the unit.	Move the unit to provide with sufficient clearance. Relocate if necessary.
	Faulty thermostat.	Call in the specialized service technician.
	Poor door seal.	Check seals and adjust.
	Room too warm.	Ventilate the room appropriately.
	The door is being opened too often or is not closed.	Restrict door opening or close door.
	The light switch is defective.	Check if light goes out after the door is shut.
Other additional maintenance procedures require specialized tools and instrumentation.		

## BASIC DEFINITIONS

**Adiabatic process.** A process in which there is no transference of heat. This implies  $\Delta Q = 0$ .

**BTU.** This is a unit for determining the heat transference in the English System. BTU is the acronym for the *British Thermal Unit*. One BTU is the quantity of heat that must be transferred for increasing the temperature of one pound of water from 63 °F to 64 °F.

**Calorie.** This is a quantity of heat which must be transferred to a gram of water to raise the temperature by 1 °C. This definition applies when under normal conditions (atmospheric pressure equal to 760 mm Hg, gravity acceleration equal to 9.81 m/s<sup>2</sup>); the temperature of a gram of water is increased from 14.5 to 15.5 °C.

**Entropy.** Measure of a system's energy that is unavailable for work, or of the degree of a system's disorder. The reversible differential changes of entropy are expressed by means of the following equation:

$$dS = \frac{dQ}{T}$$

Where:

dQ: heat absorbed from a reserve at temperature T during an infinitesimal reversible change of the state.

T: temperature of the reserve.

The following equation must be carried out for any reversible cycle change.

$$\Delta S = \int dS = \frac{dQ}{T} = 0$$

If the cycle is irreversible, it must be:

$$\Delta S = \int \frac{dQ}{T} < 0$$

**Heat.** This is a form of transferred energy over the limit of a system at a given temperature, to another one at a lower temperature by virtue of the temperature difference between the two systems. When a system of great mass [M] is placed in contact with another of small mass [m'] at a different temperature, the resulting final temperature is close to the initial temperature of the greater mass system. It is therefore said that a quantity of heat  $\Delta Q$  has been transferred from the system of higher temperature to the system of lower temperature. The heat quantity  $\Delta Q$  is proportional to the change in temperature  $\Delta T$ . The proportion constant [C], called the system's caloric capacity, allows the following relationship  $\Delta Q = C\Delta T$  to be established, from which it is inferred that one of the consequences of the change in temperature in a system is the transference of heat.

**Latent heat.** The quantity of thermal energy required for a change in phase to occur in a substance, for example: from liquid phase to vapour phase.

**Refrigerant gas.** A substance (i.e. coolant) used as a medium in the processes of heat absorption.

**Specific heat.** The quantity of heat required to increase the unit of mass by one degree.

**Sensitive heat.** The quantity of energy required for increasing the temperature of the refrigerant gas upon absorbing heat. For example: the quantity of heat required for raising the temperature from 15 to 20 °C or from 30 to 40 °C.

**Thermal system.** A device which operates in a thermodynamic cycle and carries out a certain positive quantity of work as a result of the transference of heat between a body at high temperature to a body at low temperature.



# Chapter 19



## Clinical Chemistry Analysers

<b>GMDN Code</b>	35513	—	34549*
<b>ECRI Code</b>	15-551	18-505	15-551
<b>Denomination</b>	Clinical chemistry analysers	Analysers, point-of-care (portable)	Dry chemistry analyser

\* Subcategory under GMDN code 35513

Chemistry analysers measure the concentration of analytes in blood or other bodily fluids based on specific chemical reactions by photometry. Applications vary from clinical diagnostic, drug abuse monitoring to forensic testing, etc. Chemistry analysers comprise among others, dry chemistry analysers using sample-impregnated dipsticks onto which chemical reactions are detected, and wet chemistry analysers testing analytes in solution. Various models of chemistry analysers are available, some designed to measure a single analyte, e.g. glucometers, haemoglobinometers; others to measure up to more than ten. Chemistry analysers are available as bench top instruments with various degrees of automation or in portable formats. Some are adapted to tropical conditions with electronic components protected from high humidity. Chemistry analysers group a large family of instruments including various photometers and colorimeters (see Chapter 20). Other common terms used to define these are: general chemistry analyser, clinical analyser or cholesterol meter, glucometer, haemoglobinometer (see Chapter 20) etc. for single-analyte instruments.

### Bench top dry chemistry analyser and related materials



Photo courtesy of F. Hoffmann-La Roche AG

### PHOTOGRAPHS OF CHEMISTRY ANALYSERS

#### Portable dry chemistry analyser



Photo courtesy of Siemens Healthcare Diagnostics Inc. ©2008

#### Wet chemistry analyser



Photo courtesy of F. Hoffmann-La Roche AG



## PURPOSE OF CHEMISTRY ANALYSERS

In the clinical laboratory, the chemistry analyser is used to measure one analyte or various analytes such as glucose, urea, creatine, haemoglobin, cholesterol, etc., in blood, urine, serum or plasma. It is also used to perform liver function tests.

## OPERATION PRINCIPLE

### Dry chemistry analyser

A dry chemistry analyser is a reflectance photometer. Figure 27 of Chapter 11 shows the interaction of light with matter and light reflection also called reflectance. Reflectance photometry quantifies the intensity of a chemical or biochemical reaction generating colour on a surface (e.g., slide, test strip, dipstick or test patch). Light is emitted at a specific wavelength onto the test strip by the instrument's light source (e.g. light emitting diodes or LEDs). The coloured product absorbs that wavelength of light. The more analyte in the sample, the more product (colour) and the less the light is reflected. The instrument's detector measures the reflectance of this colorimetric enzymatic or chemical reaction on the test dipstick or strip and converts it into an electronic signal. This signal is translated into the corresponding concentration of analyte in the bodily fluid tested and the concentration is then printed and/or shown on a LED digital display.

### Wet chemistry analyser

The wet chemistry analyser is a photometer. As opposed to a spectrophotometer, it does not have a prism or transmission grating. One of several or a single colour filter is used to measure the absorption of light in liquid samples

according to the Beer- Lambert law (see Chapter 11). The wet chemistry analyser generally uses a light source such as a halogen lamp with filters. More recent models use a single LED or several LEDs at specific wavelengths. Tests performed on wet chemistry analysers are based on the production of a coloured compound of the analyte with specific reacting reagents. The colour is directly proportional to the concentration of analyte(s) in solution. Typically, measurements are performed between 304 and 670 nm or with additional filters. Some instruments have the capacity to perform kinetic measurement through time.

## COMPONENTS

### Dry chemistry analyser

There are various designs of dry chemistry analysers. One feature of these instruments is the compartment or window where the test strip is placed. Designs vary according to manufacturers. The compartment is either closed with a flap cover or the strip is inserted into the instrument manually or through an advance mechanism. The light source is usually one Light Emitting Diode (LED) or several, with specific wavelength(s). The approach for reflectance measurement varies in different designs of dry chemistry analysers. It can be performed directly as shown in Figure 60, or in a chamber of square or spherical shape. The following Figures show an Ulbricht's sphere (also called integrating sphere) and how it measures reflectance.

In Ulbricht's spheres, one or more LEDs of key wavelength(s), e.g. 567, 642 and/or 951 nm act(s) as the light source(s) to accommodate various tests. The receptors are two symmetrical photodiodes, the reference ( $D_r$ ) and a measuring one, (D).

**Figure 60.** Basic diagram of reflectance photometry on a test strip. Arrows illustrate the light path. The dashes represent the change in intensity due to the effect of the colour on the reaction zone of the test strip.

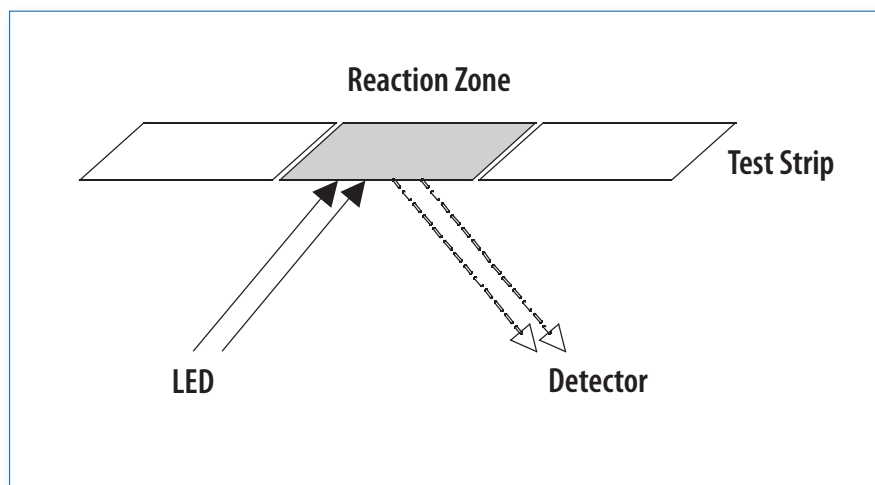

**Figure 61. Ulbricht's sphere.**

Photo courtesy of Gigahertz-optik GmbH

The light emitted by the LED is uniformly reflected from the white inner wall of the sphere. Photodiode  $D_R$  measures the intensity of the diffused light ( $I_0$ ) and photodiode  $D$  measures the light intensity diffusely reflected from the test portion of the strip ( $I$ ). The  $I_0/I$  ratio is proportional to the reflectance value  $R$ . The reflectance measured is converted into a concentration or activity value based on test-specific standard curves.

### Wet chemistry analyser

Wet chemistry analysers also widely vary in design. The common basic features are the photometric components described in the Figure below. Additional accessories vary widely depending on the degree of automation and sophistication of the instrument. Wet chemistry analysers are often equipped with peripheral or integrated computer and printer. Advanced instruments provide concentration of the targeted analytes in the relevant units of measure.

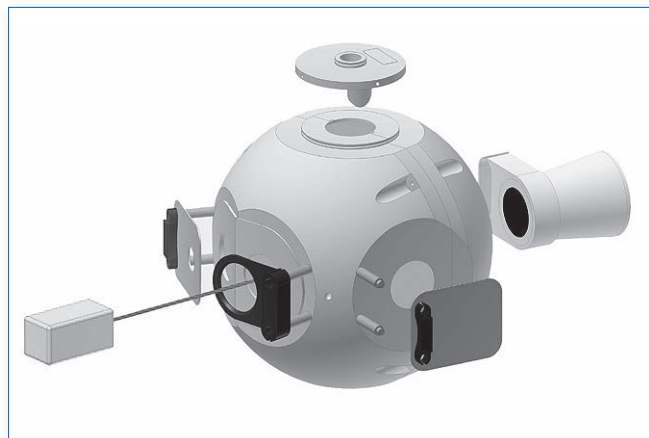
### INSTALLATION REQUIREMENTS

1. Unpack the chemistry analyser carefully.
2. Ensure that the instrument is placed away from direct sunlight, stray light or heat sources.
3. Place the instrument on a firm bench near a power outlet (if not battery operated).
  - a. The outlet must have its respective ground pole in order to guarantee the protection and safety of the operator and the equipment. Chemistry analysers generally operate at 110-120 V/60 Hz or 220-230 V/50Hz.
  - b. If not battery operated, protect the chemistry analyser from power surges using a voltage stabilizer.
4. Follow the manufacturer specifications for the installation of specific models.
5. Keep specialized packaging for future use or return for repair.
6. For added safety, some instrument models may be locked in a cupboard when not in use.

### OPERATION OF THE DRY CHEMISTRY ANALYSER

Only staff trained and authorized to use the **dry chemistry analyser** are allowed to operate the instrument. The procedure below is based on the use of a particular instrument. Refer to the instruction manual for other dry chemistry analyser models.

1. Connect the instrument to its power supply and switch on.
2. Warm up time should be displayed in seconds. For other instruments, wait 15 minutes before use, or as indicated by the manufacturer.

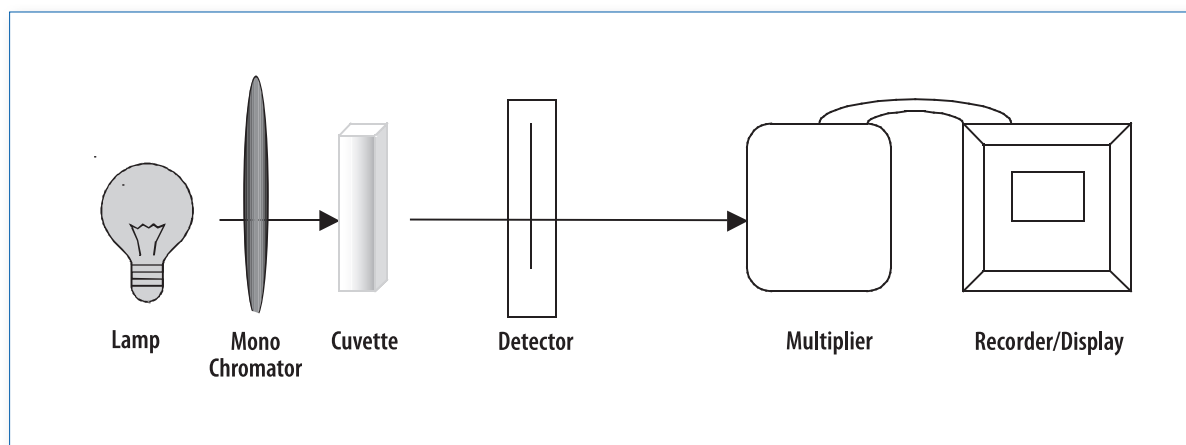
**Figure 62. Basic components of a photometer. (Note that in some instruments, the filter is placed between the cuvette and the detector.)**

3. When READ appears on the screen or the appropriate time has elapsed, proceed with the testing intended.
4. Take a reagent strip out of the vial.
5. Using a pipette, draw the appropriate amount of sample (e.g. 32 µl) avoiding air bubbles in the tip.
6. Remove the aluminium foil from the application zone of the strip without bending it.
7. Apply the sample to the centre of the red application zone avoiding touching the strip with the pipette tip.
8. Open the flap, place the strip on the guide and insert horizontally into the instrument until a click is heard.
9. Close the flap. The display confirms that the correct test-specific magnetic code is read by the instrument, e.g. GLU for glucose.
10. The time before the results are to appear, is displayed in seconds.
11. The concentration of the analyte is usually displayed in mg/dl.
12. After use, open the flap and remove the strip.
13. Turn off by switching off at the wall socket if applicable and removing the plug or disconnecting the battery terminals.

#### OPERATION OF THE WET CHEMISTRY ANALYSER

Only staff trained and authorized to use the **wet chemistry analyser** are allowed to operate the instrument. The procedure below is based on the use of a portable semi-automated wet chemistry analyser with inbuilt filters and digital display. Refer to the instruction manual from the manufacturers when using other models.

1. Connect the instrument to the power supply and switch on.
2. Warm up time should be displayed in seconds.
3. Prepare all the solutions in test tubes in a rack, i.e. blank, standards, test solutions.
4. Once the instrument is ready, blank the instrument.
5. Read each one of the test tubes.
6. Record the results.
7. Turn off by switching off at the wall socket if applicable and removing the plug or disconnecting the battery terminals.

#### ROUTINE MAINTENANCE OF CHEMISTRY ANALYSERS

Some chemistry analysers require minimal maintenance and automatically perform self-calibration routines. The guidelines below are general procedures applicable to most instruments. Always carefully follow the manufacturer's instructions for calibration, regular servicing and maintenance of your analyser.

#### Frequency: Daily

1. Any spill on, or around the instrument should be cleaned immediately.
2. At the end of the day, disconnect the power source by switching off at the wall socket if applicable and removing the plug or disconnecting the battery terminals.
3. For **dry chemistry analysers**: Do not leave test strips in the instrument. Regularly clean the window or compartment where test strips are inserted and keep it closed. Use a soft, clean damp swab.
4. For **wet chemistry analysers**: Keep the sample chamber empty and closed when not in use.
5. Cover the instrument after use.
6. Store appropriately away from dust.

#### Frequency: As needed

1. Replace blown fuses and bulbs according to the manufacturer's instructions.
2. If the equipment is faulty, consult a qualified biomedical engineer.

#### Frequency: Monthly

The window and/or front surface of the photodetector should be inspected and cleaned with lens tissue.

#### Frequency: Every six months

1. Inspect the instrument visually to verify the integrity of its components according to the manufacturer's specifications.
2. Verify that the buttons or control switches and mechanical closures are mounted firmly and that their labels are clear.
3. Ensure that all the accessories are clean and intact.
4. Check the adjustment and condition of nuts, bolts and screws.
5. Make sure the electrical connections do not have cracks or ruptures. Test that they are joined correctly.
6. If applicable:
  - a. Verify that cables securing devices and terminals are free from dust, grime or corrosion.
  - b. Verify that cables are not showing signs of splicing or of being worn out.
  - c. Examine that the grounding system (internal and external) is meeting the electric code requirements.
7. Make sure the circuit switches, fuse box and indicators are free from dust, corrosion and grime.
8. Check lamp alignment if recommended by the manufacturer.

**Frequency: Annually**

These tests must be performed by an electrician (for instruments using main power), engineer or other trained personnel. Results must be recorded and retained for follow-up through time.

1. Check the installation location for safety of the electrical (for instruments using main power only) and the physical infrastructures.
2. For instruments using main power:
  - a. Check that the voltage is appropriate and does not vary more than 5% from the voltage in the equipment specifications.
  - b. Check that the polarity of the outlet is correct.
3. Check that there is sufficient space around the instrument for the connecting cables and for adequate ventilation.
4. Test the integrity of the counter and its cleanliness.
5. Verify that the instrument is away from equipment generating vibrations and direct solar radiation.
6. Check that there is no excessive humidity, high temperature or dust.
7. Ensure that there is no source of smoke, gas or corrosive emissions nearby.

**NON-ROUTINE MAINTENANCE AND TROUBLESHOOTING**

These instructions are general guidelines for troubleshooting chemistry analysers. Since there are numerous models available, always refer to the instruction manual from the manufacturer and follow the steps recommended.

1. If there is no light passing through the system, or if its intensity is not constant, change the bulb.
2. If there is light in the system but no display response, change the photocell.
3. Always replace blown fuses and bulbs according to the manufacturer's instructions.
4. If the equipment is faulty, consult a qualified biomedical engineer.
5. If the chemistry analyser fails to switch on, check the electric socket outlet. Plug and check the fuse or the battery terminals.
6. In case of a major breakdown, consult a qualified biomedical engineer.



TROUBLESHOOTING TABLE		
PROBLEM	PROBABLE CAUSE	SOLUTION
The analyser does not start.	The on and off switch is in the off position.	Move the switch to the on position.
	There is no electric energy in the feed outlet.	Verify the general electric feed. Test that some safety mechanism has not misfired.
	The electric feed cable is not well connected.	Connect the feed cable firmly.
	The batteries are worn out or not well connected.	Check the batteries connection and status. Replace or recharge if necessary.
The command buttons do not respond.	The initialization of the equipment during start-up is incomplete.	Turn off the equipment and switch on again.
	An incorrect command was activated, during start-up.	
The serial port does not respond.	There was incomplete initialization of the equipment during start-up.	Turn off the equipment and switch on again.
	The interconnection cable is not properly connected.	Verify the connection.
The LCD screen is difficult to read.	The contrast control is maladjusted.	Adjust the contrasts.
	Base lighting system burnt out.	Call the company representative.
The printer is blocked.	Paper jam.	Remove the excess paper with finely pointed tweezers.
		Remove the paper and reinstall again.
The printer's paper does not auto feed or advance.	The printer paper is installed erroneously.	Reinsert the roll of paper correctly.
	The front edge of the paper is not aligned or is folded.	Reinsert the roll of paper. Cut the front edge and realign in the feed system.
	The paper feed control does not respond.	Call the company representative.
The cuvette does not fit in the sample holder compartment of the wet chemistry analyser.	The cuvette is of wrong size.	Use the size of cuvette specified by the manufacturer.
	The cuvette's adjustment mechanism is incorrectly placed.	Correct the position of the adjustment mechanism.
The test strip is not read by the dry chemistry analyser.	The strip was not placed correctly in the analyser.	Make sure the usual click is heard when the strip is placed if applicable.
		Check that the strip was placed in the analyser in the correct orientation and with the black underside facing down.
The dry chemistry analyser does not perform as expected.	The incorrect test strip was used.	Check that the strip corresponds to the test required. Repeat assay with the correct strip if needed.
	The instrument is defective.	Perform the instrument checks as recommended by the manufacturer. Some instruments provide on screen user guidance to follow and quality control strips to check the optical system.

## BASIC DEFINITIONS

**Analyte.** Component of a bodily fluid (e.g. blood, urine, etc.) which itself cannot be measured, but with certain properties which can be measured using a medical device designed for that purpose. For example lactate cannot be measured but lactate concentration can. Common analytes evaluated in clinical chemistry include cholesterol, urea, creatin, glucose, etc., which are measured to assess the health status of patients.

**Reflectance (R).** Ratio between the intensity of light reflected ( $I_0$ ) on a surface with that of the incident light ( $I$ ),  $I_0/I$ .

**Test strip.** Flat testing device containing test reagents and materials used for diagnostic purposes. Test strips of various degrees of complexity have been developed. These can simply consist of filter paper with bound reactive or of an elaborated system of reagent paper, transport fibres, reagent/indicator layers and magnetic strips with data encoded. The **test or reaction zone** is the area where the reaction takes place and where it is read by a dry chemistry analyser or directly by an operator.

**Note:** Other relevant definitions may be found in Chapter 11.

# Chapter 20



## Colorimeters

<b>GMDN Code</b>	<b>36910</b>	<b>38837</b>	<b>15146</b>
<b>ECRI Code</b>	<b>18-257</b>	<b>18-258</b>	<b>15-146</b>
<b>Denomination</b>	<b>Photometer, filter, automated</b>	<b>Photometer, filter, manual</b>	<b>Haemoglobin analysers (Haemoglobinometer)</b>

### PHOTOGRAPH OF COLORIMETER

#### Portable haemoglobinometer



Photo courtesy of Hemocue AB

#### PURPOSE OF THE COLORIMETER

A colorimeter is an electrically powered instrument which measures the concentration of analytes in coloured solutions. It is a simple version of a photometer. The difference in the quality of its filters makes it less sensitive. The colorimeter is used for clinical chemistry, namely for determining haemoglobin concentrations. Colorimeters are made by several manufacturers and include types with inbuilt individual removable filters or filter wheels for up to ten wavelengths. Some models are adapted for hot and humid climates with gelatine filters encased in glass to prevent fungal growth and coated individual components to prevent corrosion. Colorimeters may be

manual or semi-automated. Absorbance readings are done with needle or digital readouts. The haemoglobinometer is a portable colorimeter designed to provide direct, accurate haemoglobin concentration readings in g/dl or g/l. It will also be covered in this chapter.

#### OPERATING PRINCIPLE

A colorimeter uses filters to produce light of a single wavelength selected according to the colour of the solution being measured. The coloured light passes through the sample and the amount of light emerging is measured on a scale of absorbance. The absorbance is directly proportional to the concentration of the coloured compound in the solution according to Beer-Lambert law (see Chapter 11). It can usually measure reliably between 0 and 0.7 absorbance units. Calibration factors are higher for colorimeters than for photometers as they are less sensitive. Calibration factors for specific methods or reagents are usually provided by manufacturers or in the literature.

Haemoglobinometers measure the concentration of haemoglobin in blood. The majority of models is manually operated and uses main or battery cell power. New models have rechargeable batteries and/or use solar energy as a source of power. Most require dilution of blood before haemoglobin measurement. Some models use a device for collecting blood without dilution; these devices are single use and disposable, thus increasing the cost of haemoglobin estimation.

## COMPONENTS

The basic components of colorimeters are similar to those of a photometer as shown in Figure 62, Chapter 19. As mentioned earlier in this chapter, these instruments are simpler and due to the quality of their filters, less sensitive. The light source may be a diode lamp emitting monochromatic light. Alternatively light produced by a tungsten or halogen lamp may be filtered to achieve the required wavelength. Depending on the model, the controls of the instrument may feature the following:

1. Display window
2. ON/OFF button
3. Cuvette chamber
4. Test button
5. Reference button
6. Various modes selection button, e.g., Absorbance/%Transmittance, Kinetics (not on all models)

## INSTALLATION REQUIREMENTS

1. A clean, dust, fume and smoke free environment, away from direct sunlight is required.
2. Unpack carefully and assemble following instructions from the manufacturer if applicable.
3. Place the instrument on a firm bench and, if required, near (no more than 1.5 m away) an electric power outlet with a ground pole.
  - a. The outlet must have its respective ground pole in order to guarantee the protection and safety

of the operator and the equipment. Colorimeters generally operate at 110-120 V/60 Hz or 220-230 V/50Hz.

- b. If not battery operated, protect the instrument from power surges using a voltage stabilizer.
4. Follow the manufacturer specifications for the installation of specific models.
5. For added safety, the instrument may be locked in a cupboard when not in use. This may not be possible for large models, although these could be locked in another fashion if judged necessary.

## OPERATION OF THE COLORIMETER

Only staff trained and authorized to use the **colorimeter** are allowed to operate the instrument. This section is based on the use of the portable colorimeter model, equipped with inbuilt filters and a digital display. Other models may require different procedures and manufacturer's instructions should always be followed.

1. Connect the unit to the power supply and switch ON.
2. Allow 15 minutes for the instrument's optical and electronic systems to warm up.
3. Select the correct wavelength for the compound to be tested e.g. 540 nm for haemoglobincyanide.
4. Select "absorbance" using the Mode button.
5. Arrange all the required solutions in a test rack: blank (reagent containing no sample); standard of known concentration and test solutions (samples).

Figure 63. Controls on a portable colorimeter

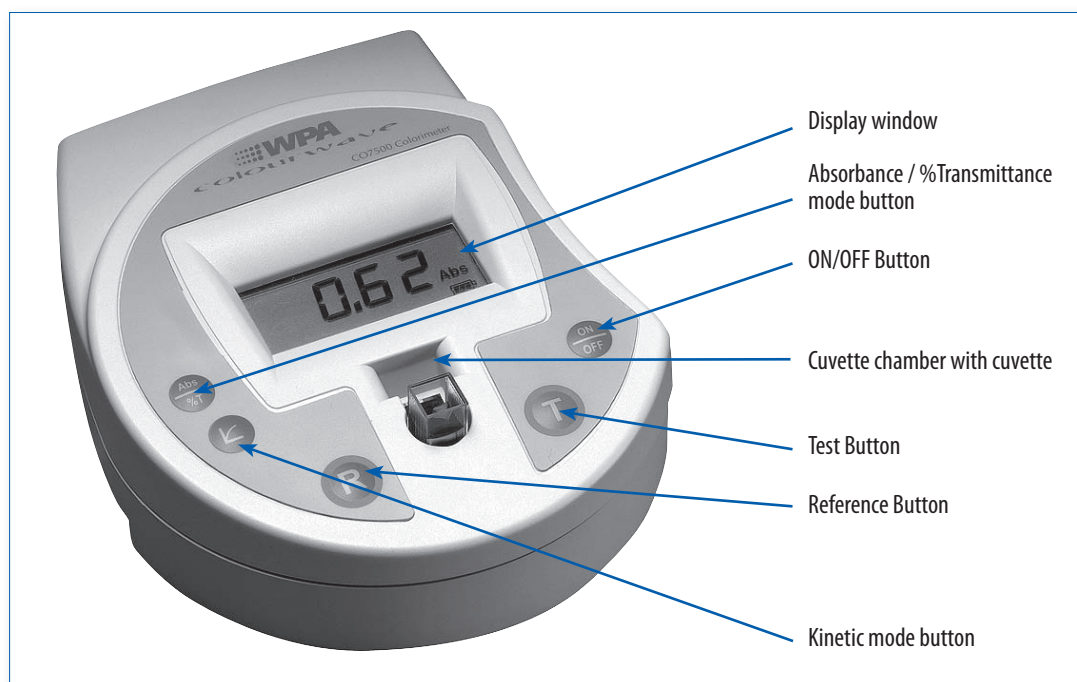

Photo courtesy of Biochrome Ltd

6. Carefully clean the cuvette using lint-free soft tissue or lens paper to avoid scratches. Always hold by the opaque ground side.
7. Transfer the blank solution into the cuvette and place it into the sample compartment with the clear sides facing the light path.
8. Close the chamber and set the display to zero using the SET BLANK control.
9. Remove the cuvette from the compartment and pour the solution back into its original test tube.
10. Pour the standard solution into the cuvette and read the absorbance.
11. Repeat step 9.
12. Read the test solutions in the same fashion.
13. Using a table of values obtained from a calibration curve derived from the instrument, read the concentration of the test samples against the absorbance.
14. After use, switch off the power supply and cover the equipment to protect it from dust.
15. Rinse the cuvette with distilled water, drain dry and wrap in soft material. Store carefully into a small box to prevent scratches and dust.
11. Remove the blank from the compartment and pour it back into the original test tube.
12. Pour the standard solution into the cuvette and place it in the compartment.
13. Close the cover and wait 3 sec. Register the reading from the digital display.
14. Remove the standard from the compartment and pour it back into the original test tube.
15. Pour the diluted sample solution into the cuvette and place it in the compartment.
16. Close the cover and wait 3 seconds and register the reading from the digital display.
17. Remove the sample from the compartment and pour it back into the original test tube.
18. Repeat steps 16-17 for each sample to be tested.
19. Rinse the cuvette with distilled water. Drain dry, wrap in soft material and store in a small box to prevent scratches.
20. Turn off by switching off or disconnecting at the wall socket if applicable. If not, remove the plug or disconnect the battery terminals.
21. Store in a locked drawer or in another suitable location.

## OPERATION OF THE HAEMOGLOBINOMETER

Only staff trained and authorized to use the **haemoglobinometer** are allowed to operate the instrument. This section describes the operation of a portable haemoglobinometer with LED light source and digital display. Different models require different procedures and manufacturer's instructions should always be followed.

1. Connect the instrument to the power supply and switch ON or use the internal power source.
2. Place the ON/OFF switch on the ON position.
3. Choose readout to be used routinely, e.g. g/Dl.
4. Warm-up time should be displayed in seconds if applicable. For other models wait 15 minutes or the time recommended by the manufacturer.
5. Prepare all the solutions in test tubes in a rack, i.e. blank, standards, test solutions.
6. Leave at room temperature for 10 minutes to equilibrate.
7. Meanwhile, carefully clean the cuvette using a soft tissue to avoid scratching.
8. Avoid touching the sides of the cuvette facing the light path; hold the cuvette by the opaque sides that will not face the light path.
9. Transfer the blank solution into the cuvette and place it in the sample compartment with the clear sides facing the light path.
10. Blank the instrument: close the cover and wait approximately 3 sec and adjust the display knob at 0:00.

## ROUTINE MAINTENANCE

Maintenance should be performed by qualified personnel. This section describes general routine maintenance for colorimeters and haemoglobinometers. Some models may require different procedures. Always carefully follow the manufacturer's instructions for regular servicing and maintenance of the colorimeter or haemoglobinometer.

### Frequency: Daily

1. Any spill on, or around the instrument should be cleaned immediately.
2. At the end of the day, turn off the instrument or disconnect the power source or the battery terminals as appropriate.
3. Keep the cuvette chamber empty and closed when not in use.
4. Cover the instrument after use. Store appropriately, protected from dust.

### Frequency: As needed

1. Replace blown fuses and bulbs according to the manufacturer's instructions.
2. If the equipment is faulty, consult a qualified biomedical engineer.

### Frequency: Monthly

The window and/or front surface of the photodetector should be inspected and cleaned with lens tissue.

**Frequency: Every six months**

1. Inspect the instrument visually to verify the integrity of its components according to the manufacturer's specifications.
2. Verify that the buttons or control switches and mechanical closures are mounted firmly and that their labels are clear.
3. Ensure that all the accessories are clean and intact.
4. Check the adjustment and condition of nuts, bolts and screws.
5. Make sure the electrical connections do not have cracks or ruptures. Test that these are joined correctly.
6. If applicable:
  - a. Verify that cables securing devices and terminals are free from dust, grime or corrosion.
  - b. Verify that cables are not showing signs of splicing or of being worn out.
  - c. Examine that the grounding system (internal and external) is meeting the electric code requirements.
7. Make sure the circuit switches or interrupters, fuse box and indicators are free from dust, corrosion and grime.
8. Check lamp alignment if recommended by the manufacturer.

**Frequency: Annually**

These tests must be performed by an electrician or engineer and results must be recorded and archived for follow-up through time.

1. Check the installation location for safety of the electrical and the physical infrastructures.
2. For instruments using main power:
  - a. Check that the voltage is appropriate and does not vary more than 5% from the voltage in the equipment specifications.
  - b. The polarity of the outlet is correct.
3. Check that there is sufficient space around the instrument for the connecting cables and for adequate ventilation.
4. Test the integrity of the counter and its cleanliness.
5. Verify that the instrument is away from equipment generating vibrations and direct solar radiation.
6. Check that there is no excessive humidity, dust or high temperature.
7. Ensure that there is no source of smoke, gas or corrosive emissions nearby.

**General maintenance**

Refer to the general maintenance of spectrophotometer in Chapter 11 for the cleaning of spills and replacement of batteries.

**Cuvette use and maintenance**

Cuvettes must be rigorously clean for accurate measurements. Clean these as described in Chapter 11. Additional recommendations are as follow:

1. Always hold cuvettes by their opaque, non-optical walls.
2. Unless specified by the operator's manual, do not perform any measurements without performing a blank determination.
3. Use a single cuvette or a set of matched cuvettes for proper performance of the instrument. Note: Absorbance of cuvettes should not exceed 0.01 when measuring distilled water. To avoid incorrect results, a cuvette exceeding this limit should not be used as part of a set unless it is matched with one with the same absorbance reading when measuring distilled water.
4. Remove bubbles present in the solution by gently tapping the cuvette with the finger.
5. Ensure that there is a high enough level of solution in the cuvette (above the light beam) so that the reflection of light from the surface does not interfere with the reading.
6. All solutions used and the specimen to be measured should be clear. If the mixed reagent solution and specimen is turbid, the measurement must be repeated after checking and confirming the cuvette's transparency and cleanliness.
7. If a kinetic measurement is performed over a long period of time, seal the cuvette to avoid evaporation causing erroneously high readings.
8. When performing readings on a series of specimens, readjust the zero every 5 to 10 measurements by reading the blank solution to avoid a drift of the zero.
9. Do not leave the cuvette in the instrument.
10. If using semi-micro or micro-cuvettes, ensure correct positioning in the light path to avoid false readings due to partially reflected light.
11. Store in a dust-free box to prevent damage as scratched or damaged cuvettes can lead to incorrect measurements.

### Optical filters use and maintenance

1. Handle removable filters by the circumference to avoid contamination.
2. Keep spare filters in a dust-free box to insure protection from breakage or scratches.
3. Ensure that a filter is in its slot when the lamp is turned ON to avoid damage to the photocell. Store filters in the appropriate storage box when the instrument is not in use.
4. When the instrument is cool and turned OFF, clean the filters and optical window with lens tissue as instructed by the manufacturer.

### Light source use and maintenance

1. Turn OFF the lamp after each use to maximize its life span. Some manufacturers recommend keeping a record log of the instrument lamp use.
2. Check lamp periodically. Replace if it is the cause of instability in the absorption signal.

### Lamp alignment

The following are procedures to align new lamps. Refer to the instructions from the manufacturer to insure the procedure is performed according to specifications of the instrument model in use.

Realign the new lamp as follows:

1. Place a clean cuvette filled with distilled water in position in the instrument.
2. Set the meter to a mid-scale reading, e.g. at 50% transmission.
3. Move each optical component slightly in turn and check if the reading was affected.
4. If needed, adjust the lamp alignment for maximum transmission.
5. Alternatively, place a white card in front of the photocell (some instruments will allow this). Observe the image of the lamp on the card. It should be vertical and in focus. If not, adjust the lamp alignment until the best image is obtained.

Troubleshooting tables containing problems sometimes encountered with colorimeters are presented below. Since instrument models vary widely the following guidelines take precedence:

1. Always refer to the instruction manual from the manufacturer.
2. If an instrument fails to switch on, if applicable, check the electric socket outlet. Plug and check the fuse or the battery terminals.
3. In case of a major breakdown, consult a qualified biomedical engineer.

## TROUBLESHOOTING TABLE

### Automated Colorimeter

PROBLEM	PROBABLE CAUSE	SOLUTION
The colorimeter does not start.	The on/off switch is in the off position.	Move the switch to the on position.
	There is no electric energy in the feed outlet.	Verify the main electric feed. Verify that some electrical safety mechanism has not been misfired.
	The electric feed cable is not well connected.	Connect the feed cable firmly.
The keyboard or buttons do not respond.	The initialization of the equipment during start-up is incomplete.	Turn off the equipment and switch on again.
	An incorrect command was activated, during start-up.	
The serial port does not respond.	There was incomplete initialization of the equipment during start-up.	Turn off the equipment and switch on again.
	The interconnection cable is not connected well.	Verify the connection.
The LCD screen is difficult to read.	The contrast control is maladjusted.	Adjust the contrasts.
	Base lighting system burnt out.	Call the representative.
The printer is blocked.	Paper jam.	Remove the excess paper with finely pointed tweezers.
		Remove the paper and reinstall again.
The printer's paper does not auto feed or advance.	The printer paper is installed incorrectly.	Reinsert the roll of paper.
	The front edge of the paper is not aligned or folded.	Reinsert the roll of paper. Cut the front edge and realign in the feed system.
	The paper feed control does not respond.	Call the representative.
The cuvette does not enter in the sample holder compartment.	The cuvette is of wrong size.	Use the size of cuvette specified by the manufacturer.
	The cuvette's adjustment mechanism is incorrectly placed.	Correct the position of the adjustment mechanism.
The reading shows fluctuations.	There are interferences in the light's path.	Verify that the cuvette is not scratched.
		Verify that there are no particles floating in the cuvette.
		Rub the optic walls of the cuvette with a piece of clean cloth.
		Verify that the working range (wavelength and dilution) selected is appropriate for the sample analyzed.
The reading shows negative values. There is no absorbance reading.	There is no sample.	Add a sample to the solution.
	The cuvette is incorrectly positioned.	Verify the orientation of the cuvette. Clear sides should face the light path.
	The wavelength is erroneously selected.	Adjust the wavelength to the range compatible with the analysis.
	The equipment was calibrated with a sample in place of a standard solution.	Calibrate with a standard solution or with distilled water.

<b>Non-automated Colorimeter</b>		
<b>PROBLEM</b>	<b>PROBABLE CAUSE</b>	<b>SOLUTION</b>
The source lamp does not light up.	The filament is broken.	Replace the lamp.
	The safety fuse is burnt out.	Replace the fuse.
	There is resistance in the lamp's filament.	Replace the lamp.
	The voltage is incorrect.	Review the voltage. Check the feed source.
Low readings in the meter or in the galvanometer.	The source lamp is defective.	Replace the lamp.
	The photocell is dirty or defective.	Clean or replace the photocell.
	The multiplier is defective.	Change or repair the multiplier.
	The source lamp's voltage is low.	Adjust the voltage.

### BASIC DEFINITIONS

Since these instruments are based on the photometry principles, relevant definitions may be found in Chapter 11.







# Bibliography

American Society for Testing and Materials, Annual book of Standards 1994. *Water Hardness Determination*. Method ASTM D1126-92.

Aston, R., *Principles of Biomedical Instrumentation and Measurement*, Merrill Publishing Company, 1990.

Blues, J., Bayliss, D., Buckley, M., *The calibration and use of piston pipettes*, National Physical Laboratory, Teddington, Middlesex, UK, 2004 ([www.npl.co.uk](http://www.npl.co.uk)).

Carter J., Lema O., *Practical Laboratory Manual for Health Centres in Eastern Africa*, AMREF, 1994.

Cheesborough, Monica, *District Laboratory Practice in Tropical Countries*, Part 1, Tropical Health Technology, UK, 2005.

*Class II (Laminar Flow) Biohazard Cabinetry*, NSF International Standard, NSF-49-1992.

Gordon, J., Sonntag, R., *Fundamentals of Classical Thermodynamics*, New York, John Wiley and Sons, 2<sup>nd</sup>. Editions, 1976.

*Guidelines for calibration in laboratories*, Drinking water Inspectorate by LGC (Teddington) TLTD, December 2000.

Fitzgerald, A., Kingsley, C., Kusko, A., *Electric Machinery*, Mc Graw Hill Co., 1971.

*HealthCare Product Comparison System*, ECRI, 2002.

Holman, J., *Heat Transfer*, New York, Mc Graw Hill Co., 1972.

Johns, Warren L. *Selection of basic laboratory equipment for laboratories with limited resources*, World Health Organization, 2000.

Lobkowicz, F., Melissinos A., *Physics for Scientist and Engineers*, vol. 2, Philadelphia. W.B. Saunders Company, 1975.

*Maintenance and repair of laboratory equipment, hospital and diagnostic by image*, Geneva, WHO, 1996.

*Manual for Basic Techniques for a Health Laboratory*. WHO, Geneva 2<sup>nd</sup>. Edition, 2003.

*Manual on the management, maintenance and use of blood cold chain equipment*, WHO, Geneva, 2005.

*Primary Containment for Biohazards: Selection, Installation and Use of Biological Safety Cabinets*, Washington DC U.S. Department of Health and Human Services, Center for Disease Control and Prevention and National Institute of Health, 2<sup>nd</sup>. Edition, 2000.

Ram S., Lamba, De La Cuétara, R., *Locally Produced Low Cost Equipment Project*, UNESCO-IUPAC.

*The blood cold chain, guide to the selection and procurement of equipment and accessories*, WHO, Geneva, 2002.

*The Laboratory Safety Guidelines*, Public Health Agency of Canada.

*The microscope, A Practical Guide*, New Delhi, India, WHO, Regional Office for South-East Asia, 1999.

*Universal Medical Devices Nomenclature System™ (UMDNS)*, Product category Thesaurus, ECRI, 5200 Bulter Pike, Plymouth Meeting, PA, USA 2000.



# CONTACT

## Diagnostics and Laboratory Technology

World Health Organization

20 Avenue Appia

CH-1211 Geneva 27

Switzerland

E-mail: [diagnostics@who.int](mailto:diagnostics@who.int)

[www.who.int/diagnostics\\_laboratory](http://www.who.int/diagnostics_laboratory)

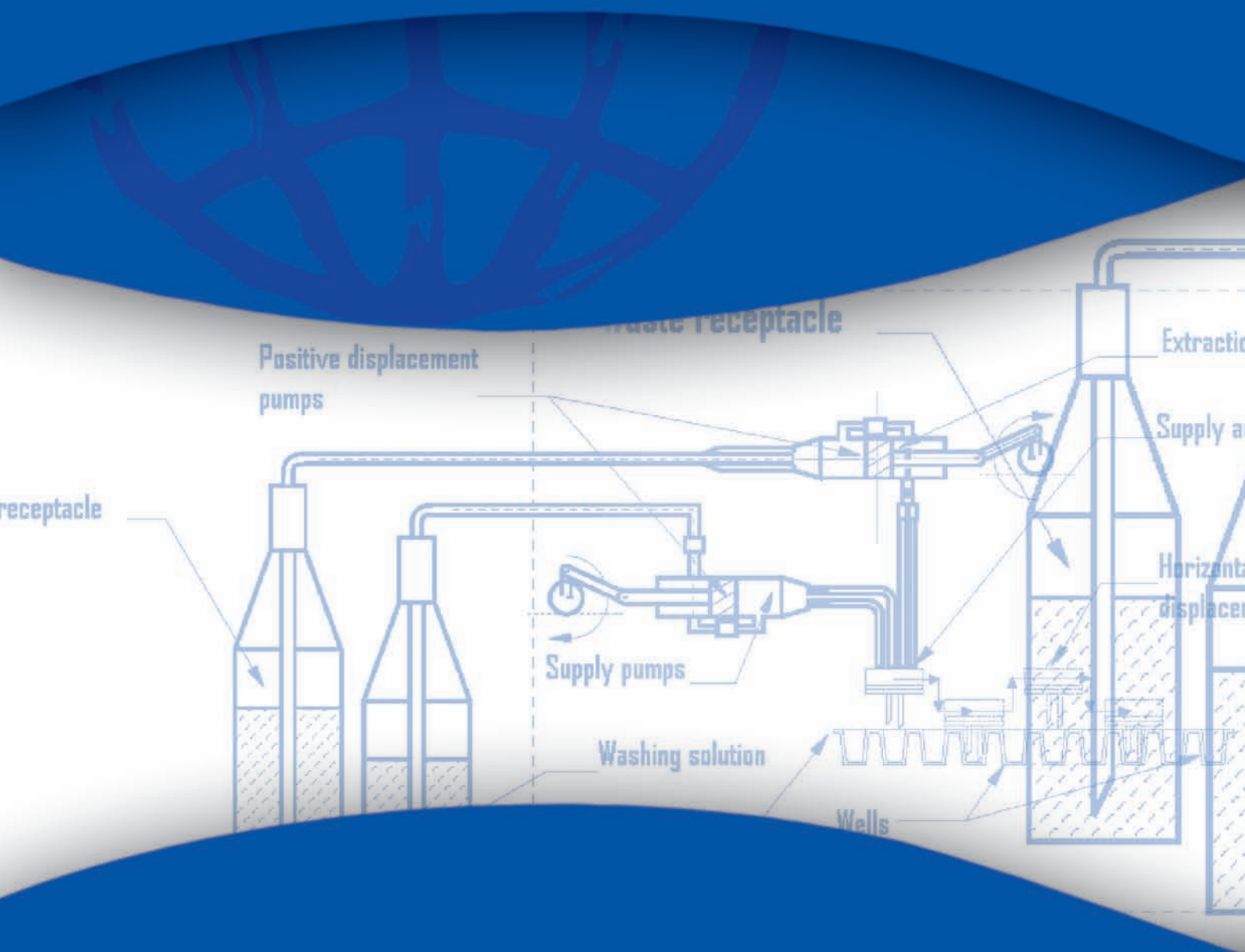

ISBN 92 4 159635 0



9 789241 596350